

Subject	Page
How to Order	1
Chip Resistors Selection Guide	2~3
General Purpose Chip Resistors (1Ω~10MΩ)	4
Low Ohmic Chip Resistors (0.02Ω~1Ω)	5
Ultra Low Ohmic Sensing Chip Resistors (0.001Ω~0.025Ω)	6
Chip Resistors Array : Convex Termination	7
WA06W Chip Resistors Array 16P8R	8
Chip Resistors Array : Concave Termination	9
WT04X Chip Resistors Network	10
WA04P Chip Attenuator	11
Special Chip Resistors	12
WFxxY Series of Gold Terminations	12
WFxxG Series of High Ohmic Chip Resistors	12
WFxxM Series of Trimmable Chip Resistors	13
WFxxV Series of High Voltage Chip Resistors	13
WFxxP/WWxxP Series of High Power Chip Resistors	14
WFxxS Series of Surge Chip Resistors	15
Precision Chip Resistors	15
Test and Requirements	16
Packing on Tape and Reel	17
Footprint Design	18
Storage and Handling Condition	19
Recommendation of Soldering Profile	19

■ HOW TO ORDER

WR	06	X	1000	F	T	L
Type code R: Discrete 1~10MR	Size code 25 : 2512 (6432) 20 : 2010 (5025) 18 : 1218 (3248) 12 : 1206 (3216) 10 : 1210 (3225) 06 : 0603 (1608) 08 : 0805 (2012) 04 : 0402 (1005) 02 : 0201 (0603)	Functional code X : Normal W : 1% for<10ohm and>1Mohm	Resistance E24(J tol.) : 2 significant digits followed by No. of zeros and a blank e.g. : 3ohm=3R0_ 10ohm=100_ 220ohm=221_ 56Kohm=563_ (" " means blank) E24,E96(F tol.) : 3 significant digits followed by No. of zeros	Tolerance F : +/- 1% J : +/- 5% P : Jumper	Packaging code P : 4" reel taping T : 7" reel taping A : 7" reel taping 15Kpcs Q : 10" reel taping G : 13" reel taping R : 0603 2mm pitch taping B : Bulk K : Bulkcase	Termination code _ = SnPb base (" " means blank) L = Sn base (Lead free) R = Pb ≤ 100 ppm (total)
WW	25	M	R002	F	T	L
Type code R : < 1ohm	Size code 25 : 2512 (6432) 20 : 2010 (5025) 18 : 1218 (3248) 12 : 1206 (3216) 10 : 1210 (3225) 08 : 0805 (2012) 06 : 0603 (1608) 04 : 0402 (1005)	Functional code X : Normal M : Sensing type N : Sensing type, High Power W : Thick film low TCR type F : Metal Foil P : Power (2512 size=2 watt, 2010 size=0.75 watt, 1210 size=0.5 watt, 1206 size=0.5 watt, 0805 size=0.25 watt, 0603 size=0.125 watt)	Resistance "R" followed by 3 significant digits e.g. : 0.1ohm=R100 0.033ohm=R033 0.56ohm=R560	Tolerance F : +/- 1% G : +/- 2% J : +/- 5%	Packaging code P : 4" reel taping T : 7" reel taping Q : 10" reel taping G : 13" reel taping R : 0603 2mm pitch taping B : Bulk K : Bulkcase	Termination code _ = SnPb base (" " means blank) L = Sn base (Lead free) G = Au base S = Ag base
WF	04	H	1001	B	T	L
Type code F: Special function	Size code 25 : 2512 (6432) 20 : 2010 (5025) 18 : 1218 (3248) 12 : 1206 (3216) 10 : 1210 (3225) 08 : 0805 (2012) 06 : 0603 (1608) 04 : 0402 (1005)	Functional code G : High ohmic (>10Mohm) H : Thick film, Precision tolerance<1% K : Thick film, TCR50ppm M : Trimmable P : Power (>WR and WW series) S : Surge T : Thin film, TCR50ppm U : Thin film, TCR25ppm V : High voltage X : Special resistance Y : E24/E96 resistance with special termination (non SnPb or Sn base), ≥1%	Resistance E24(J tol.) : 2 significant digits followed by No. of zeros and a blank e.g. : 3ohm=3R0_ 10ohm=100_ 220ohm=221_ 56Kohm=563_ (" " means blank) E24,E96(F tol.) : 3 significant digits followed by No. of zeros	Tolerance B : +/- 0.1% C : +/- 0.25% D : +/- 0.5% F : +/- 1% G : +/- 2% J : +/- 5% K : +/- 10% L : +/- 15% M : +/- 20% P : Jumper	Packaging code P : 4" reel taping T : 7" reel taping Q : 10" reel taping G : 13" reel taping R : 0603 2mm pitch taping B : Bulk K : Bulkcase	Termination code _ = SnPb base (" " means blank) L = Sn base (Lead free) G = Au base S = Ag base
WA	04	Y	103_	J	T	L
Type code A: Isolated Resistor Array	Size code 06 : 0603 (1608) 04 : 0402 (1005)	Functional code X : *4, convex Y : *2, convex W : *8, convex T : *4, concave U : *2, concave P : *3, convex (Attenuator)	Resistance E24(J tol.) : 2 significant digits followed by No. of zeros and a blank e.g. : 3ohm=3R0_ 10ohm=100_ 220ohm=221_ 56Kohm=563_ (" " means blank) E24,E96(F tol.) : 3 significant digits followed by No. of zeros	Tolerance F : +/- 1% J : +/- 5% P : Jumper	Packaging code T : 7" reel taping Q : 10" reel taping G : 13" reel taping B : Bulk K : Bulkcase	Termination code _ = SnPb base (" " means blank) L = Sn base (Lead free)
WT	04	X	103_	J	T	L
Type code T: Network Resistors	Size code 04 : total package size 1206 (3216)	Functional code X : *8, convex	Resistance E24(J tol.) : 2 significant digits followed by No. of zeros and a blank e.g. : 3ohm=3R0_ 10ohm=100_ 220ohm=221_ 56Kohm=563_ (" " means blank) E24,E96(F tol.) : 3 significant digits followed by No. of zeros	Tolerance J : +/- 5%	Packaging code T : 7" reel taping B : Bulk	Termination code _ = SnPb base (" " means blank) L = Sn base (Lead free)

Remark: 1. Detail product part number, functional code, tolerance combination,...please refer to specific data sheet.

2. Example: (" " means blank)

Chip-R 0805 size, 4.3ohm, 5% Normal type, SnPb termination, 5000pcs taped in reel: WR08X4R3_JT_

Chip-R 0805 size, 4.3ohm, 5% Normal type, Sn Lead free termination, 5000pcs taped in reel: WR08X4R3_JTL

Chip-R 0603 size, 100ohm, 5% Normal type, SnPb termination, 5000pcs taped in reel: WR06X101_JT_

Chip-R 0603 size, 100ohm, 1% Normal type, Sn termination, 5000pcs taped in reel: WR06X100FTL

Low ohmic Chip-R 2512 size, 0.1ohm, 1% Normal type, SnPb termination, 4000pcs taped in reel: WW25XR100FT_

Low ohmic Chip-R 2512 size, 0.1ohm, 1% Normal type, Sn Lead free termination, 4000pcs taped in reel: WW25XR100FTL

Chip-R array 0603x4, 10Kohm, 5% convex with SnPb termination, 5000pcs taped in reel: WA06X103_JT_

Chip-R 0402 size, 220ohm, Normal type, Gold termination, 5% 10,000pcs taped in reel: WF04Y221_JTG

Chip-R 0603 size, 0ohm, Normal type, SnPb termination, 5000pcs taped in reel: WR06X000_PT_

■ Chip Resistors Selection Guide

■ General Purpose Chip-R

Series	Size	Rated Power	TCR (ppm/°C)	Tolerance	Resistance
WR02X	0201 (0603)	1/20W	300*	±1%	10Ω ~ 1MΩ
			300*	±5%	1Ω ~ 10MΩ
WR04X	0402 (1005)	1/16W	200	±1%	1Ω ~ 10MΩ
			200*	±5%	
WR06X	0603 (1608)	1/10W	100	±1%	
			200	±5%	
WR08X	0805 (2012)	1/8W	100	±1%	
			200	±5%	
WR12X	1206 (3216)	1/4W	100	±1%	
			200	±5%	
WR10X	1210 (3225)	1/3W	200	±1%	
			200	±5%	
WR18X	1218 (3248)	1W	100	±1%	
			100	±5%	
WR20X	2010 (5025)	1/2W	200	±1%	
			200*	±5%	
WR25X	2512 (6432)	1W	200	±1%	
			200*	±5%	

Remark : 1. Means Detail resistance v.s. TCR and ordering code please refer to specific specifications.
 2. Pb free terminations upon customer requested.
 3. Standard jumper resistors are not designed for fusing applications, designers shall apply dedicate fusible resistors or standard fuse in it's precision circuits.

■ Low Ohmic Chip-R

Series	Size	Rated Power	TCR (ppm/°C)	Tolerance	Resistance	
WW25X	2512 (6432)	1W	≤1500**	±1%	0.020Ω ~ 0.976Ω	
				±5%	0.015Ω ~ 0.910Ω	
WW18X	1218 (3248)	1W		±1%	0.020Ω ~ 0.976Ω	
				±5%	0.015Ω ~ 0.910Ω	
WW20X	2010 (5025)	1/2W		±1%	0.020Ω ~ 0.976Ω	
				±5%	0.015Ω ~ 0.910Ω	
WW10X	1210 (3225)	1/3W		≤200	±1%	0.100Ω ~ 0.976Ω
					±5%	0.100Ω ~ 0.976Ω
WW12X	1206 (3216)	1/4W			±1%, ±2%, ±5%	0.020Ω ~ 0.976Ω
WW08X	0805 (2012)	1/8W			±1%, ±2%, ±5%	0.10Ω ~ 0.976Ω
WW06X	0603 (1608)	1/10W			±1%, ±2%, ±5%	0.10Ω ~ 0.976Ω
WW04X	0402 (1005)	1/16W			±1%, ±5%	0.10Ω ~ 0.976Ω

Remark : 1. "****" Detail resistance v.s. TCR please refer to specification.
 2. Pb free terminations upon customer requested.

■ Ultra Low Ohmic Sensing Chip-R

Series	Size	Rated Power	TCR (ppm/°C)	Tolerance	Resistance
WW25M	2512 (6432)	1W	≤100	±1%, ±5%	0.001Ω ~ 0.025Ω
WW25N	2512 (6432)	2W	≤100	±1%, ±5%	0.001Ω ~ 0.025Ω

■ Chip Resistors Array

Series	Size	Rated Power	TCR (ppm/°C)	Termination Type	Tolerance	Resistance
WA06X	1206 (0603x4)	1/10W	≤200	Convex	±5%	10Ω ~ 1MΩ
WA04X	0805 (0402x4)	1/16W	≤300	Convex	±5%	
WA04Y	0404 (0402x4)	1/16W	≤300	Convex	±5%	
WA06T	1206 (0603x4)	1/10W	≤200	Concave	±5%	
WA04T	0805 (0402x4)	1/16W	≤300	Concave	±5%	
WA04U	0404 (0402x2)	1/16W	≤300	Concave	±5%	
WA06W	1606 (0602x4)	1/16W	≤200	Convex	±5%	10Ω ~ 100KΩ

Remark : Pb free terminations upon customer requested.

■ Chip Resistors Network

Series	Size	Rated Power	TCR (ppm/°C)	Termination Type	Tolerance	Resistance
WT04X	1206 (10P8R)	1/16W	≤200	Convex	±5%	10Ω ~ 100KΩ

Remark : Pb free terminations upon customer requested.

■ Special Functionality Chip-R

Type	Series	Size	Rated Power	TCR (ppm/°C)	Tolerance	Resistance
Gold Termination	WF06Y	0603 (1608)	1/10W	≤ 100	±1%	10Ω ~ 1MΩ
				≤ 200	±5%	1Ω ~ 10MΩ
	WF04Y	0402 (1005)	1/16W	≤ 100	±1%	10Ω ~ 1MΩ
				≤ 200	±5%	1Ω ~ 10MΩ
High Ohmic	WF12G	1206 (3216)	1/4W	≤ 300	±5%	11MΩ ~ 30MΩ
	WF08G	0805 (2012)	1/8W			
	WF06G	0603 (1608)	1/16W			
Trimnable	WF20M	2010 (5025)	1/2W	≤ 200	0/-20% 0/-30%	1Ω ~ 10MΩ
	WF12M	1206 (3216)	1/4W			
	WF08M	0805 (2012)	1/8W			
	WF06M	0603 (1608)	1/10W			
High Precision	WF12H	1206 (3216)	1/4W	≤ 100	±0.1% ±0.5%	10Ω ~ 1MΩ
	WF08H	0805 (2012)	1/8W			
	WF06H	0603 (1608)	1/10W			
	WF04H	0402 (1005)	1/16W	≤ 200	±0.1% ±0.5%	10Ω ~ 1MΩ
	WF12T	1206 (3216)	1/8W	≤ 50	±1% ±0.5%	10Ω ~ 1MΩ
	WF08T	0805 (2012)	1/10W			10Ω ~ 1MΩ
	WF06T	0603 (1608)	1/16W			10Ω ~ 330KΩ
	WF04T	0402 (1005)	1/20W			10Ω ~ 100KΩ
	WF12U	1206 (3216)	1/8W	≤ 25	±0.1% ±0.5%	10Ω ~ 1MΩ
	WF08U	0805 (2012)	1/10W			10Ω ~ 1MΩ
	WF06U	0603 (1608)	1/16W			10Ω ~ 330KΩ
	WF04U	0402 (1005)	1/20W			10Ω ~ 100KΩ

Remark : Pb free terminations upon customer requested.

■ Chip Attenuator

Series	Size	Type	Termination Type	Tolerance	Attenuation	Impedance
WA04P	0402x2 (1005x2)	4p3R, π type	Convex	±0.2db ~ 1dB	1dB ~ 10dB	50Ω

■ General Purpose Chip Resistors (1Ω~10MΩ)

■ Feature

1. High reliability and stability
2. Reduced size of final equipment
3. Lower assembly costs
4. Higher component and equipment reliability

■ Description

The resistors are constructed in a high grade ceramic body (aluminum oxide). Internal metal electrodes are added at each end and connected by a resistive paste that is applied to the top surface of the substrate. The composition of the paste is adjusted to give the approximate resistance required and the value is trimmed to within tolerance by laser cutting of this resistive layer.

The resistive layer is covered with a protective coat. Finally, the two external end terminations are added. For ease of soldering the outer layer of these end terminations is a Lead-tin or Tin solder (Pb free) alloy.

■ Application

1. Consumer electrical equipment, PDA, Digital Camcorder, ...
2. EDP, Computer application
3. Mobile phone, Telecom
4. Power supply, Battery charger, DC-DC power converter
5. Digital meter
6. Automotives



■ Quick Reference Data

Series No.	WR25X	WR20X	WR18X	WR10X	WR12X	WR08X	WR06X	WR04X	WR02X
Size Code	2512 (6432)	2010 (5025)	1218(3248)	1210 (3225)	1206 (3216)	0805 (2012)	0603 (1608)	0402 (1005)	0201 (0603)
Resistance Range ±5% Tolerance (E24) ±1% Tolerance (E24+E96)	1Ω~10MΩ, 0Ω 1Ω~10MΩ								1Ω~10MΩ,0Ω 10Ω~1MΩ
TCR (ppm/°C) >10Ω ≤10Ω	≤ ± 200 ≤ ± 300		≤ ± 100 ≤ ± 200		≤ ± 100 -300 ~ +500				≤ ± 300
Max. dissipation @ T _{amb} =70°C	1.0 Watt	1/2 Watt	1.0 Watt	1/3 Watt	1/4 Watt	1/8 Watt	1/10 Watt	1/16 Watt	1/20 Watt
Max. Operation Voltage (DC or RMS)	250V	200V	200V	200V	200V	150V	50V	50V	25V
Climatic category (IEC 60068)	55/155/56								≥55/125/56
Basic Specification	JIS C 5201-1 / IEC 60115-1								

Note :

1. This is the maximum voltage that may be continuously supplied to the resistor element, see "IEC publication 60115-8"
2. Max. Operation Voltage : So called RCWV (Rated Continuous Working Voltage) is determined by
 $RCWV = \sqrt{\text{Rater Power} \times \text{Resistance Value}}$ or Max. RCWV listed above, whichever is lower.
3. Lead Free (Pb free) products are upon customer request.
4. The resistance range 1 ~ 10Ω and 1M ~ 10MΩ with 1% tolerance please refer to WR12W / WR08W / WR06W / WR04W series specification.

■ Physical Dimensions

Unit: mm

Size	2512(6432)	2010(5025)	1218(3248)	1210(3225)	1206(3216)	0805(2012)	0603(1608)	0402(1005)	0201(0603)
L	6.40 ± 0.20	5.00 ± 0.20	3.05 ± 0.15	3.10 ± 0.10	3.10 ± 0.10	2.00 ± 0.10	1.60 ± 0.10	1.00 ± 0.05	0.60 ± 0.03
W	3.20 ± 0.20	2.50 ± 0.20	4.60 ± 0.20	2.60 ± 0.10	1.60 ± 0.10	1.25 ± 0.10	0.80 ± 0.10	0.50 ± 0.05	0.30 ± 0.03
T	0.60 ± 0.10	0.55 ± 0.10	0.55 ± 0.10	0.55 ± 0.10	0.60 ± 0.15	0.50 ± 0.15	0.45 ± 0.15	0.35 ± 0.05	0.23 ± 0.03
Tb	0.90 ± 0.25	0.60 ± 0.25	0.50 ± 0.25	0.50 ± 0.20	0.45 ± 0.20	0.40 ± 0.20	0.30 ± 0.15	0.25 ± 0.10	0.15 ± 0.05
Tt	0.65 ± 0.25	0.65 ± 0.25	0.45 ± 0.25	0.50 ± 0.20	0.50 ± 0.20	0.40 ± 0.20	0.30 ± 0.10	0.20 ± 0.10	0.10 ± 0.05

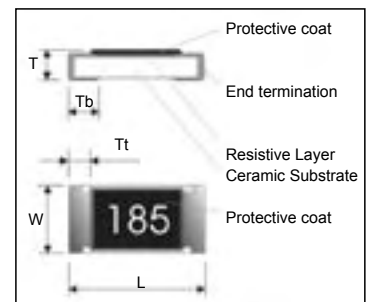

■ Power Deration Curve

For resistors operated in ambient temperature over 70°C, power rating should be derated in accordance with the following figures.

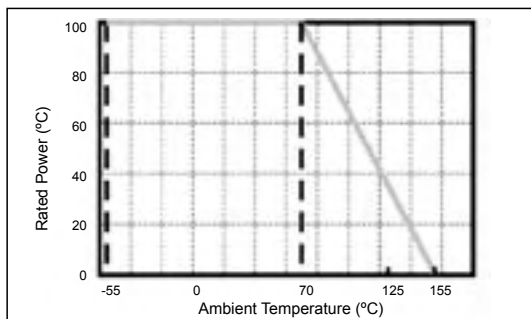

For Climatic category (IEC 60068) 55/155/56

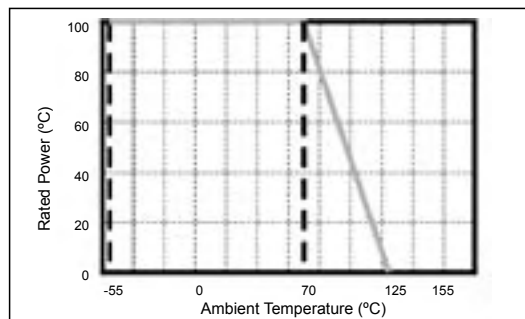

For Climatic category (IEC 60068) 55/125/56 (for 0201 type)

■ Low Ohmic Chip Resistors (0.02Ω~1Ω)

■ Function For Low Ohmic Chip Resistors

The low ohmic resistors are used to sense output current in power supply, automotive and engine control management system, and other power sensing application. As shows in figure below, the typical function of low ohmic (power) chip resistor is to be a current sensor (R_{sense}) to generate the sensing voltage (V_s) for the purpose of feedback control when output current (I_o) passed on it. The sensing voltage be treated as a signal to trigger the switches (CMOS) ON/OFF duration so that to monitor and/or adjust the output current from inductor.

Simplify to say, $V_s = I_o \times R_{sense}$.

On general case, this feedback voltage is setting around 100mV for considering both on power saving and noise robustness. To sense a 5 ampere average output current, the R_{sense} resistance value therefore be required as $100\text{mV} / 5\text{A} = 20\text{m}\Omega$, the power dissipation will be :

$$P = I^2 \times R = 5\text{A}^2 \times 20\text{m}\Omega = 0.5\text{ Watt}$$

A low ohmic chip resistor with a power rating of 1.0 watt is recommended on this application in case the power safety margin is taken into account.

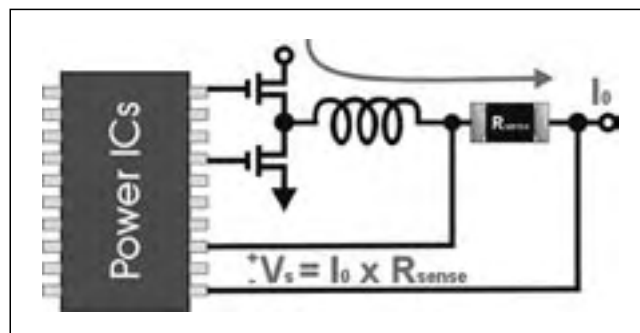

■ Quick Reference Data

Series No.	WW25X	WW20X	WW18X	WW10X	WW12X	WW08X	WW06X	WW04X
Size Code	2512 (6432)	2010 (5025)	1218(3248)	1210(3225)	1206 (3216)	0805 (2012)	0603 (1608)	0201 (0603)
Resistance Tolerance	±5%, ±1%			±1%, ±5%		±5%, ±2%, ±1%		±5%, ±1%
Resistance Range	0.020Ω ~ 0.976Ω			0.100Ω ~ 0.976Ω		0.020Ω ~ 0.976Ω		0.100Ω ~ 0.976Ω
TCR (ppm/°C)								
0.02Ω ≤ R _n < 0.05Ω	≤ ± 1500					≤ ± 1500		
0.05Ω ≤ R _n < 0.10Ω	≤ ± 1000					≤ ± 1000		
0.10Ω ≤ R _n < 0.50Ω	≤ ± 500			≤ ± 200		≤ ± 500		≤ ± 600
0.50Ω ≤ R _n < 1Ω	≤ ± 300			≤ ± 200		≤ ± 300		≤ ± 600
Max. dissipation @ T _{amb} =70°C	1 Watt	0.5 Watt	1 Watt	1/3 Watt	1/4 Watt	1/8 Watt	1/10 Watt	1/16 Watt
Max. Operation Voltage (DC or RMS)	250V	200V	200V	200V	200V	100V	50V	50V
Climatic category (IEC 60068)	55/155/56							
Basic Specification	JIS C 5201-1 / IEC 60115-1							

Note :

1. This is the maximum voltage that may be continuously supplied to the resistor element, see "IEC publication 60115-8"
2. Tolerance of TCR=± 200ppm/°C
3. Power derating curve, and detail specification please refer to specific data sheets.
4. Lead Free (Pb free) products are available upon customer's request.

■ Physical Dimensions

Unit: mm

Size	2512(6432)	2010(5025)	1218(3248)	1210(3225)	1206(3216)	0805(2012)	0603(1608)	0402(1005)
L	6.40 ± 0.20	5.00 ± 0.20	3.05 ± 0.15	3.10 ± 0.10	3.10 ± 0.10	2.00 ± 0.10	1.60 ± 0.10	1.00 ± 0.05
W	3.20 ± 0.20	2.50 ± 0.20	4.60 ± 0.20	2.60 ± 0.10	1.60 ± 0.10	1.25 ± 0.10	0.80 ± 0.10	0.50 ± 0.05
T	0.60 ± 0.10	0.55 ± 0.10	0.55 ± 0.10	0.55 ± 0.10	0.60 ± 0.15	0.50 ± 0.15	0.45 ± 0.15	0.35 ± 0.05
T _b	0.90 ± 0.25	0.60 ± 0.25	0.50 ± 0.25	0.50 ± 0.20	0.45 ± 0.20	0.40 ± 0.20	0.30 ± 0.15	0.25 ± 0.10
T _t	0.65 ± 0.25	0.65 ± 0.25	0.45 ± 0.25	0.50 ± 0.20	0.50 ± 0.20	0.40 ± 0.20	0.30 ± 0.10	0.20 ± 0.10

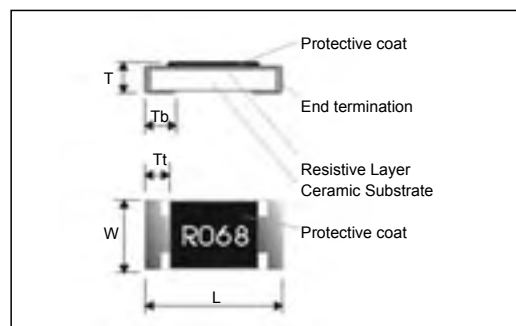

■ Ultra Low Ohmic Sensing Chip Resistors (0.001Ω~0.025Ω)

■ Description

The resistors are constructed in a high grade low resistive metal body. The resistive layer is covered with a protective coat and printed a resistance marking code over it. Finally, the two external end terminations are added. For ease of soldering the outer layer of these end terminations is a Lead-tin alloy, lead free terminations are available upon customer's request.

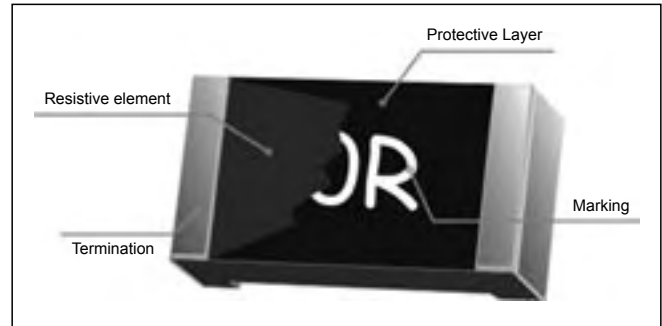

■ Quick Reference Data

Item	General Specification	
	WW25M	WW25N
Series No.	WW25M	WW25N
Size code	2512 (6432)	
Resistance Tolerance	±5%, ±1%	
Resistance Range	0.001Ω ~ 0.025Ω	
TCR (ppm/°C)	≤ 100 ppm/°C	
Max. dissipation @ T _{amb} =70°C	1 W	2 W
Max. Operation Voltage (DC or RMS)	250V	250V
Max. Overload Voltage (DC or RMS)	500V	500V
Climatic category (IEC 60068)	55/155/56	

Note :

1. This is the maximum voltage that may be continuously supplied to the resistor element, see "IEC publication 60115-8"
2. Power derating curve, and detail specification please refer to specific data sheets.
3. Lead Free (Pb free) products are available upon customer's request.

■ Physical Dimensions:

WW25M(0.002Ω~0.025Ω), WWW25N(0.003Ω~0.025Ω)

Unit: mm

Symbol	Dimensions
L	6.40 ± 0.20
W	3.20 ± 0.20
T	0.60 ± 0.15
Tt	0.65 ± 0.25
Tb	0.65 ± 0.25

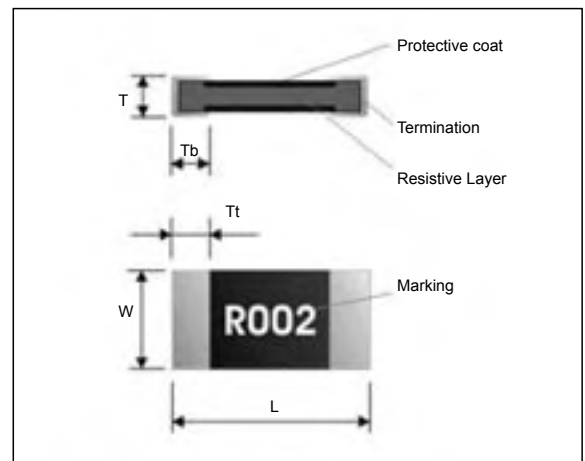

■ Physical Dimensions:

WW25M(0.001Ω), WWW25N(0.001Ω~0.002Ω)

Unit: mm

Symbol	Dimensions
L	6.40 ± 0.20
W	3.20 ± 0.20
T	0.60 ± 0.10
Tt	1.60 ± 0.25
Tb	1.60 ± 0.25

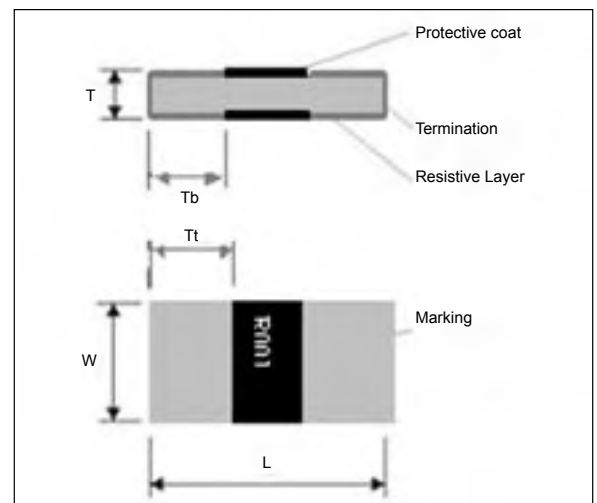

■ Chip Resistors Array : Convex Termination

■ Feature

1. High reliability and stability
2. Reduced size of final equipment
3. Lower assembly cost and higher surface mounted efficiency
4. Higher component and equipment reliability

■ Application

1. Consumer electrical equipment, PDA, Digital Camcorder, ...
2. EDP, Computer application
3. Mobile phone, Telecom
4. DIMM

■ Description and Physical Dimensions

The resistors array is constructed in a high grade ceramic body (aluminum oxide). Internal metal electrodes are added at each end and connected by a resistive paste that is applied to the top surface of the substrate. The composition of the paste is adjusted to give the approximate resistance required and the value is trimmed to within tolerance by laser cutting of this resistive layer.

The resistive layer is covered with a protective coat. Finally, the two external end terminations are added. For ease of soldering the outer layer of these end terminations is a Lead-tin or Tin solder alloy. Marking code description is depended on component size and tolerance. Following figure shown the construction of a Chip-R array.

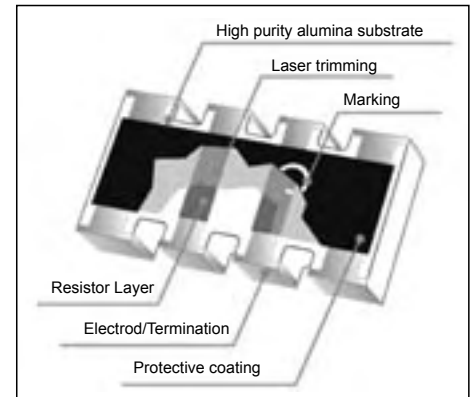

■ Physical Dimensions

Unit: mm

Type	WA06X	WA04X	WA04Y
L	3.20 ± 0.10	2.00 ± 0.10	1.00 ± 0.10
W	1.60 ± 0.10	1.00 ± 0.10	1.00 ± 0.10
T	0.50 ± 0.10	0.45 ± 0.10	0.35 ± 0.10
P	0.80 ± 0.10	0.50 ± 0.05	0.65 ± 0.10
A	0.60 ± 0.10	0.4 ± 0.10	0.34 ± 0.10
B	0.30 ± 0.10	0.20 ± 0.10	0.20 ± 0.15
C	0.40 ± 0.10	0.30 ± 0.05	-
G	0.30 ± 0.20	0.25 ± 0.10	0.25 ± 0.17

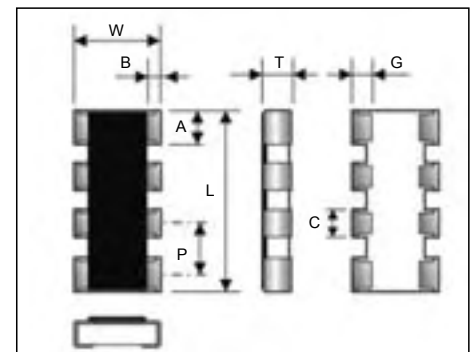

■ Quick Reference Data

Series No.	WA06X	WA04X	WA04Y
Size	0603x4 (1608x4)	0402x4 (1005x4)	0402x2 (1005x2)
Termination construction	8p4R, Convex	8p4R, Convex	4p2R, Convex
Resistance Tolerance	±5% (E24 series)		
Resistance Range	10Ω ~ 1MΩ (E24 series), Jumper (0Ω)		
TCR (ppm/°C)	≤ ± 200 ppm/°C	≤ ± 300 ppm/°C	≤ ± 300 ppm/°C
Max. dissipation @ T _{amb} =70°C	1/10 Watt	1/16 Watt	1/16 Watt
Max. Operation Voltage (DC or RMS)	50V	25V	25V
Max. Overload Voltage (DC or RMS)	100V	50V	50V
Climatic category (IEC 60068)	55/155/56		55/125/56
Basic Specification	JIS C 5201-1 / IEC 60115-1		
Circuit Mode: R1=R2(=R3=R4)			

Note :

1. Power derating curve, and detail specification please refer to specific data sheets.
2. Lead Free (Pb free) products are available upon customer's request.

■ WA06W Chip Resistors Array 16P8R

■ Description

The resistors array is constructed in a high grade ceramic body (aluminum oxide). Internal metal electrodes are added at each end and connected by a resistive paste that is applied to the top surface of the substrate. The composition of the paste is adjusted to give the approximate resistance required and the value is trimmed to within tolerance by laser cutting of this resistive layer.

The resistive layer is covered with a protective coat. Finally, the two external end terminations are added. For ease of soldering the outer layer of these end terminations is a Lead-tin or Tin (Pb free) solder alloy.

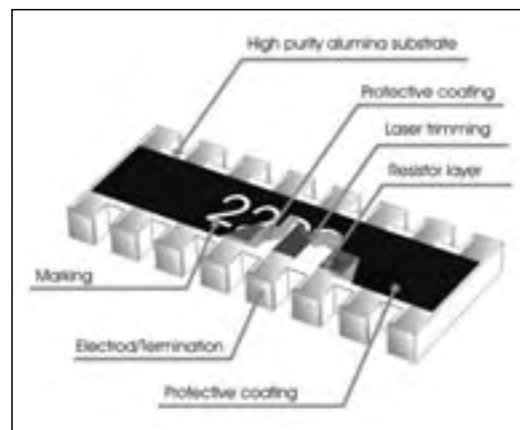

■ Quick Reference Data

Item	General Specification
Series No.	WA06W
Size	1606 (0602x8)
Termination construction	Convex type
Resistance Tolerance	±5% (E24 series)
Resistance Range	10Ω ~ 100KΩ, Jumper (0Ω)
TCR (ppm/°C)	≤ ± 200 ppm/°C
Max. dissipation @ T _{amb} =70°C	1/16 W
Max. Operation Voltage (DC or RMS)	25V
Max. Overload Voltage (DC or RMS)	50V
Climatic category (IEC 60068)	55/125/56
Circuit Mode	<p>R1=R2=R3=R4=R5=R6=R7=R8</p>

Note :

1. Power derating curve, and detail specification please refer to specific data sheets.
2. Lead Free (Pb free) products are available upon customer's request.

■ Physical Dimensions

Unit: mm

Symbol	Dimensions
L	4.00 ± 0.20
W	1.60 ± 0.15
T	0.45 ± 0.10
B	0.30 ± 0.20
G	0.30 ± 0.20
D	0.20 ± 0.10
P	0.50 ± 0.20
H1	0.40 ± 0.20
H2	0.30 ± 0.10

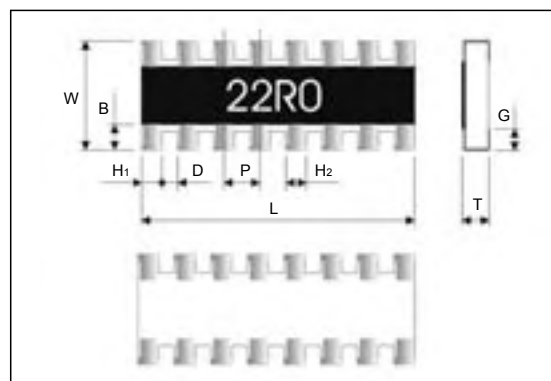

■ Chip Resistors Array : Concave Termination

■ Feature

1. High reliability and stability
2. Reduced size of final equipment
3. Lower assembly costs and higher surface mounted efficiency
4. Higher component and equipment reliability
5. Strong body and terminations
6. Excellence performance in surface mounting assembly.

■ Description and Physical Dimensions

The resistors array is constructed in a high grade ceramic body (aluminum oxide). Internal metal electrodes are added at each end and connected by a resistive paste that is applied to the top surface of the substrate. The composition of the paste is adjusted to give the approximate resistance required and the value is trimmed to within tolerance by laser cutting of this resistive layer.

The resistive layer is covered with a protective coat. Finally, the two external end terminations are added. For ease of soldering the outer layer of these end terminations is a Lead-tin or Tin solder alloy. Marking code description is depended on component size and tolerance. Following figure shown the construction of a Chip-R array.

■ Application

1. Consumer electrical equipment, PDA, Digital Camcorder, ...
2. EDP, Computer application
3. Mobile phone, Telecom
4. DIMM

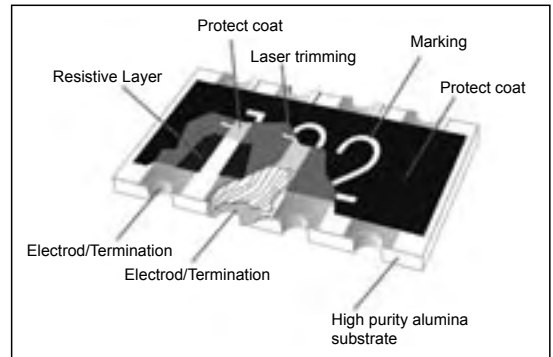

■ Quick Reference Data

Item	General Specification		
Series No.	WA06T	WA04T	
Size	0603x4 (1608x4)	0402x4 (1005x4)	
Termination construction	Concave type	Concave type	
Resistance Tolerance	±5% (E24 series)	±5% (E24 series)	
Resistance Range	10Ω ~ 1MΩ, Jumper (0Ω)	10Ω ~ 1MΩ, Jumper (0Ω)	
TCR (ppm/°C)	≤ ± 200 ppm/°C	≤ ± 300 ppm/°C	
Max. dissipation @ T _{amb} =70°C	1/10 W	1/16 W	
Max. Operation Voltage (DC or RMS)	50V	25V	
Max. Overload Voltage	100V	50V	
Climatic category (IEC 60068)	55/125/56	55/125/56	
Circuit Mode	 R1=R2=R3=R4		
	L	3.20 + 0.20/-0.10 mm	2.00 ± 0.10mm
	W	1.60 + 0.20/-0.10 mm	1.00 ± 0.10mm
	T	0.60 ± 0.20 mm	0.40 ± 0.10 mm
	P	0.80 ± 0.10 mm	0.50 ± 0.05mm
	A	0.60 ± 0.15 mm	0.25 ± 0.05 mm
	B	0.35 ± 0.15 mm	0.20 ± 0.15 mm
	C	0.50 ± 0.15mm	0.25 ± 0.05 mm
	G	0.50 ± 0.15 mm	0.25 ± 0.15mm

Note :

1. Power derating curve, and detail specification please refer to specific data sheets.
2. Lead Free (Pb free) products are available upon customer's request.

■ Quick Reference Data

Series No.	General Specification
Series No.	WA04U
Size	0402x2 (1005x2)
Termination construction	Concave type
Resistance Tolerance	±5%, ±1% (E24 series)
Resistance Range	10Ω ~ 1MΩ, Jumper (0Ω)
TCR (ppm/°C)	≤ ± 300 ppm/°C
Max. dissipation @ T _{amb} =70°C	1/16 W
Max. Operation Voltage (DC or RMS)	25V
Max. Overload Voltage	50V
Climatic category (IEC 60068)	55/155/56

Note :

1. This is the maximum voltage that may be continuously supplied to the resistor element, see "IEC publication 60115-8"
2. Max. Operation Voltage : So called RCWV (Rated Continuous Working Voltage) is determined by $RCWV = \sqrt{\text{Rated Power} \times \text{Resistance Value}}$ or Max. RCWV listed above, whichever is lower.

■ Dimensions

	WA04U
L	1.00 ± 0.10
W	1.00 ± 0.10
T	0.30 ± 0.10
P	0.50 ± 0.05
A	0.35 ± 0.10
Ab	0.35 ± 0.10
B	0.25 ± 0.15
C	0.15 ± 0.10
D	0.25 ± 0.15

Unit: mm

■ Construction

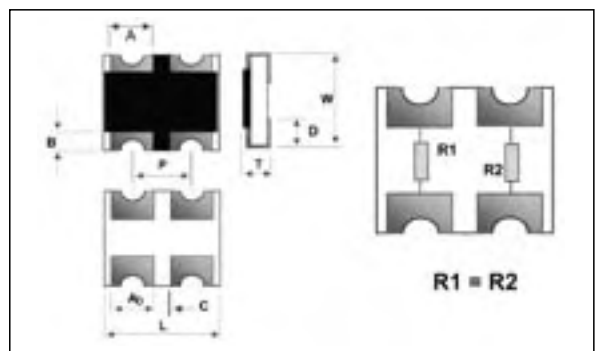

WT04X Chip Resistors Network

Description

The resistors array is constructed in a high grade ceramic body (aluminum oxide). Internal metal electrodes are added at each end and connected by a resistive paste that is applied to the top surface of the substrate. The composition of the paste is adjusted to give the approximate resistance required and the value is trimmed to within tolerance by laser cutting of this resistive layer.

The resistive layer is covered with a protective coat. Finally, the two external end terminations are added. For ease of soldering the outer layer of these end terminations is a Lead-tin solder alloy or Tin solder (Pb free) alloy.

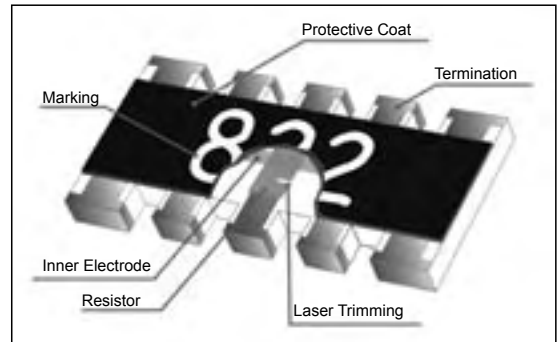

Quick Reference Data

Item	General Specification
Series No.	WT04X
Size	1206 (3216)
Termination construction	Convex type
Resistance Tolerance	±5% (E24 series)
Resistance Range	10Ω ~ 100KΩ
TCR (ppm/°C)	≤ ± 200 ppm/°C
Max. dissipation @ T _{amb} =70°C	1/16 Watt
Max. Operation Voltage (DC or RMS)	25V
Max. Overload Voltage	50V
Climatic category (IEC 60068)	55/155/56
Basic Specification	JIS C 5201-1/IEC 60115-1
Circuit Mode Resistor elements on pin1~pin4, pin6~pin9; R1=R2=R3=R4=R6=R7=R8=R9 pin5 and pin10 common (Grounded).	

Note :

1. Power derating curve, and detail specification please refer to specific data sheets.
2. Lead Free (Pb free) products are available upon customer's request.

Physical Dimensions

Unit: mm

	WT04X
L	3.30 ± 0.20
W	1.60 ± 0.15
T	0.55 ± 0.10
P	0.64 ± 0.05
A	0.50 ± 0.05
B	0.40 ± 0.15
C	0.40 ± 0.15
G	0.40 ± 0.15

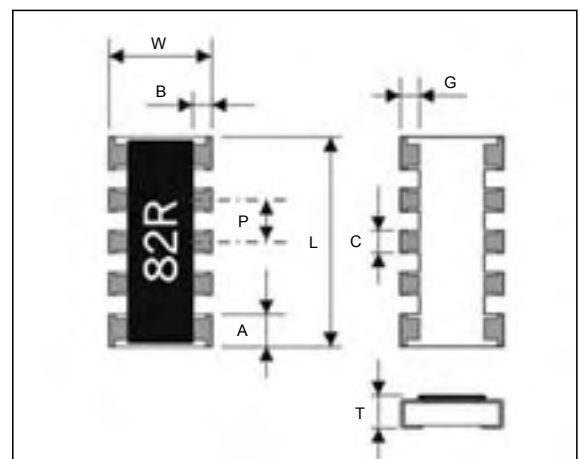

■ WA04P Chip Attenuator

■ Typical Application of Chip Attenuator

WA04	P	001	X	B	T	-
Size code	Type code	Attenuation code	Tolerance	Rated voltage	Termination	Packaging
WA04: 0402 per element	P: convex, π type attenuator	001=1dB 002=2dB 003=3dB 004=4dB 005=5dB 006=6dB 010=10dB	X: 50 Ω	A: ± 0.2 dB B: ± 0.3 dB C: ± 0.5 dB D: ± 1.0 dB	T=7" reel taped	_ = SnPb base ("_" means a blank) L = Sn base (lead free)

π -Type Attenuator (-6dB, 50W) for VSWR improvement and output frequency level matching on VCO application.

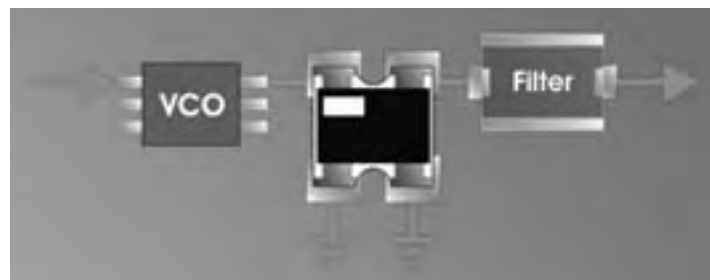

■ Quick Reference Data

Item	General Specification
Series No.	WA04P
Size	0402x2 (1005x2)
Termination construction	Convex type
Attenuation Range	1dB, 2dB, 3dB, 4dB, 5dB, 6dB, 10dB
Attenuation Tolerance	
1dB ~ 5dB	± 0.3 dB
6dB ~ 10dB	± 0.5 dB
Characteristic impedance	50 Ω
Rated power at $T_{amb}=70^{\circ}C$	0.04W / package
Limiting voltage (DC)	50V
Frequency range (DC)	Max. 2GHz
VSWR (Voltage Standing Wave Ratio)	Max. 1.3
Number of Resistors	3 resistors
Number of Terminals	4 terminals
Climatic category (IEC 60068)	55/125/56

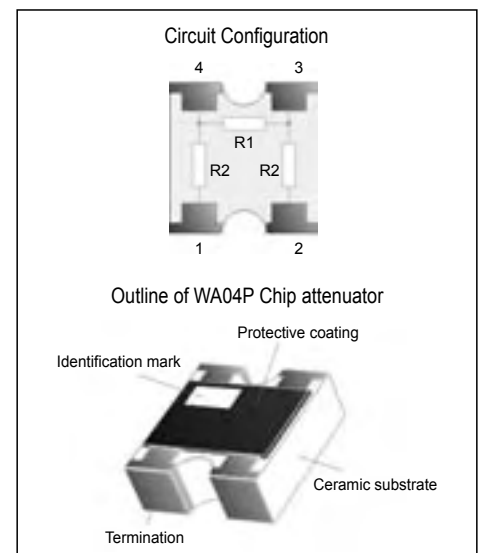

■ Physical Dimensions

Unit: mm

	WA04P
L	1.00 \pm 0.10
W	1.00 \pm 0.10
T	0.35 \pm 0.10
P	0.65 \pm 0.10
A	0.33 \pm 0.10
Ta	0.15 \pm 0.10
Tb	0.25 \pm 0.10

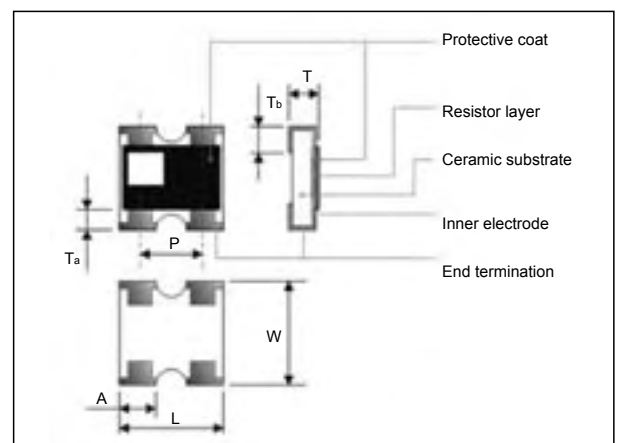

■ Special Chip Resistors

■ Feature

1. Provided gold terminations (WFxxD series) provide special application for hybrid board gluing & can replace Pd/Ag terminations
2. Provided ultra high ohmic resistance (WFxxG series) upto 30Mohm for special application
3. Provided trimmable resistors (WFxxM series) for customer special tolerance requirement.
4. Provided precision tolerance (WFxxH) to $\pm 0.1\%$ and TCR down to 50ppm/°C(WF12K) for voltage sensing application.
5. High reliability and stability
6. Reduced size of final equipment
7. Lower assembly costs
8. Higher component and equipment reliability.
9. Special resistance, tolerance are available upon customer's request.

■ WFxxY Series of Gold Terminations

■ Feature

1. High reliability and stability
2. Gold terminations provide special application for hybrid board gluing & can replace Pd/Ag terminations
3. Miniature size 0603(1608) and 0402(1005)

■ Quick Reference Data

Series No.	WF06YxxxxxG	WF04YxxxxxG
Size code	0603(1608)	0402(1005)
Resistance Tolerance	$\pm 1\%$ (E96 series), $\pm 5\%$ (E24 series)	
Resistance Range	1 Ω ~ 10M Ω ($\pm 5\%$ tolerance), 10 Ω ~ 1M Ω ($\pm 1\%$ tolerance)	
TCR (ppm/°C)	$\geq 10\Omega$ $\pm 5\%$ Tolerance $\leq \pm 200$ ppm/°C $\leq 10\Omega$ $\pm 1\%$ Tolerance $\leq \pm 100$ ppm/°C -300~+500 ppm/°C	
Max. dissipation @ T _{amb} =70°C	1/10 Watt	1/16 Watt
Max. Operation Voltage (DC or RMS)	50V	50V
Climatic category (IEC 60068)	55/125/56	
Basic Specification	JIS C 5201-1 / IEC 60115-1	

(Detail specification please refer to specific data sheets)

■ WFxxG Series of High Ohmic Chip Resistors

■ Quick Reference Data

Series No.	WF12G	WF08G	WF06G	WF04G
Size code	1206 (3216)	0805 (2012)	0603 (1608)	0402 (1005)
Resistance Range and tolerance $\pm 5\%$ tolerance	10M Ω < R \leq 30M Ω (E24 series)			
TCR (ppm/°C)	$\leq \pm 300$ ppm/°C			
Max. dissipation @ T _{amb} =70°C	1/4 Watt	1/8 Watt	1/10 Watt	1/16 Watt
Max. Operation Voltage (DC or RMS)	200V	150V	50V	50V
Climatic category (IEC 60068)	55/125/56			
Basic Specification	JIS C 5201-1 / IEC 60115-1			

(Detail specification please refer to specific data sheets)

■ Physical Dimensions

Unit: mm

	WF12G	WF08G	WF06G	WF04G
L	3.10 \pm 0.10	2.00 \pm 0.10	1.60 \pm 0.10	1.00 \pm 0.05
W	1.60 \pm 0.10	1.25 \pm 0.10	0.80 \pm 0.10	0.50 \pm 0.05
Tt	0.50 \pm 0.20	0.40 \pm 0.20	0.30 \pm 0.10	0.20 \pm 0.10
Tb	0.45 \pm 0.20	0.40 \pm 0.20	0.30 \pm 0.20	0.25 \pm 0.10
T	0.65 \pm 0.15	0.50 \pm 0.15	0.45 \pm 0.15	0.35 \pm 0.05

■ Application

1. Automotive application
2. Consumer electrical equipment
3. EDP, Computer application
4. Telecom application

■ Physical Dimensions

Unit: mm

	WF06Y	WF04Y
L	1.60 \pm 0.10	1.00 \pm 0.05
W	0.80 \pm 0.10	0.50 \pm 0.05
T	0.45 \pm 0.15	0.35 \pm 0.05
Tb	0.30 \pm 0.20	0.25 \pm 0.10
Tt	0.30 \pm 0.10	0.20 \pm 0.10

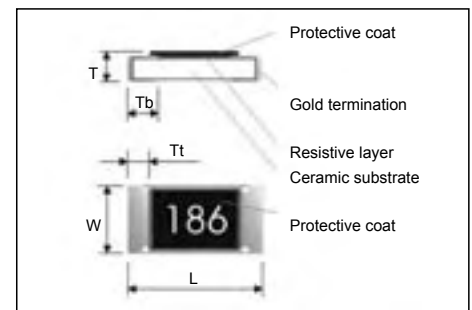

■ Feature

1. High precision, reliability and stability
2. Miniature size to 0603(1608)
3. Small and stable TCR

■ Application

1. Power supply
2. Digital meter
3. Measuring instruments
4. EDP, Computer application

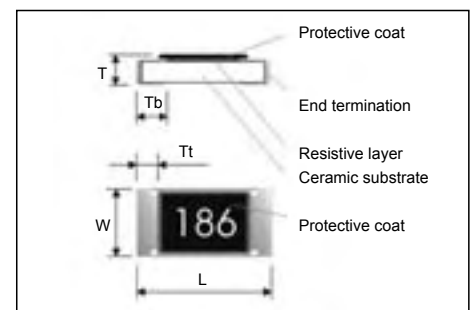

■ WFxxM Series of Trimmable Chip Resistors

■ Feature

1. High precision, reliability and stability
2. Miniature size to 0603(1608)

■ Description

The resistors are constructed on a high-grade ceramic body (aluminum oxide). Internal metal electrodes are added at each end and connected by a resistive paste, which is applied to the substrate. The composition of the paste is adjusted to give the approximate resistance required. The resistive layer is converted with a transparent protective coating. Finally the two external end terminations are added. For case of soldering the outer of these end terminations is a lead-tin alloy or Tin solder (Pb free) alloy.

■ Physical Dimensions

Unit: mm

	WF20M	WF12M	WF08M	WF06M
L	5.00 ± 0.20	3.10 ± 0.10	2.00 ± 0.10	1.60 ± 0.10
W	2.50 ± 0.20	1.60 ± 0.10	1.25 ± 0.10	0.80 ± 0.10
T	0.55 ± 0.15	0.60 ± 0.15	0.50 ± 0.15	0.45 ± 0.15
Tb	0.65 ± 0.25	0.45 ± 0.20	0.40 ± 0.20	0.30 ± 0.20
Tt	0.60 ± 0.25	0.50 ± 0.20	0.40 ± 0.20	0.30 ± 0.10

■ Quick Reference Data

Series No.	WF20M	WF12M	WF08M	WF06M
Size code	2010 (5025)	1206 (3216)	0805 (2012)	0603 (1608)
Resistance Tolerance	0/-10%(Z), 0/-20%(Y) and 0/-30%(X) E24 series			
Resistance Range	1Ω ~ 10MΩ			
TCR (ppm/°C)	≥10Ω ≤ ± 200 ppm/°C <10Ω -300~+500 ppm/°C			
Max. dissipation @ T _{amb} =70°C	1/2 Watt	1/4 Watt	1/8 Watt	1/10 Watt
Max. Operation Voltage (DC or RMS)	200V	200V	100V	50V
Climatic category (IEC 60068)	55/125/56			
Basic Specification	JIS C 5201-1 / IEC 60115-1			

■ WFxxV Series of High Voltage Chip Resistors

■ Feature

1. Special material and design for high working voltage require.
2. Compatible with flow and reflow soldering.
3. Suitable for lead free soldering.

■ Quick Reference Data

Item	General Specification		
Series No.	WF25V	WF20V	WF12V
Size code	2512 (6432)	2010 (5025)	1206 (3216)
Resistance Tolerance	± 5%		
Resistance Range	100 KΩ ~ 10 MΩ		
TCR (ppm/°C)	± 200 ppm/°C		
Max. dissipation @ T _{amb} =70°C	1 W	1/2 W	1/4 W
Max. Operation Voltage (DC or RMS)	2000V	1500V	800V
Max. Overload Voltage (DC or RMS)	4000V	3000V	1600V
Climatic category (IEC 60068)	55/155/56		

Note:

1. This is the maximum voltage that may be continuously supplied to the resistor element, see "IEC publication 60115-8"
2. Max. Operation Voltage : So called RCWV (Rated Continuous Working Voltage) is determined by RCWV = √Rated Power x Resistance Value or Max. RCWV listed above, whichever is lower.

■ Physical Dimensions

Unit: mm

	WF25V	WF20V	WF12V
L	6.30 ± 0.20	5.00 ± 0.20	3.10 ± 0.15
W	3.10 ± 0.20	2.50 ± 0.20	1.60 ± 0.15
T	0.60 ± 0.15	0.60 ± 0.10	0.55 ± 0.10
Tb	0.60 ± 0.25	0.60 ± 0.25	0.50 ± 0.25
Tt	0.90 ± 0.25	0.60 ± 0.25	0.50 ± 0.25

■ Application

1. Automotive application
2. Consumer electrical equipment
3. EDP, Computer application
4. Telecom application

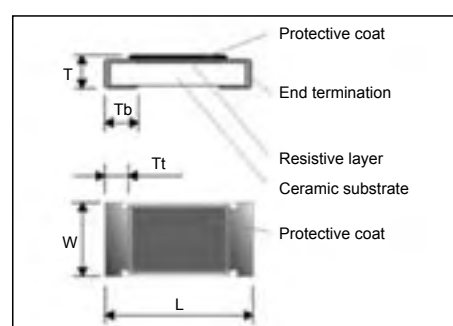
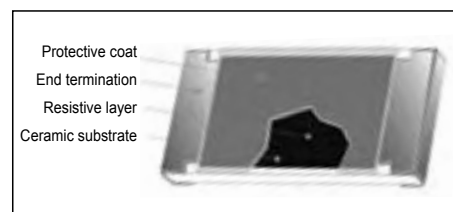

■ Trimming Conditions

Please refer to specific data sheet.

■ Application

1. Power supply
2. Automotive industry
3. Measurement instrument
4. Back light inverter
5. Medical or Military equipment

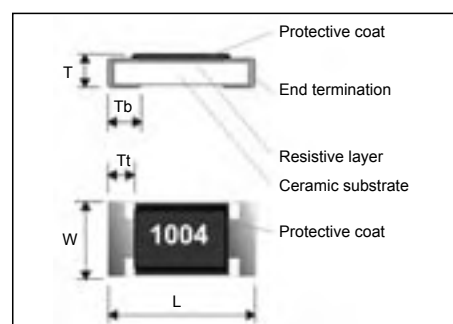

■ WFxxP/WWxxP Series of High Power Chip Resistors

■ Feature

1. High power rating and compact size
2. High reliability and stability
3. Reduced size of final equipment
4. Lead free product is upon customer requested.

■ Application

1. Power supply
2. PDA
3. Digital meter
4. Computer
5. Automotives
6. Battery charger
7. DC-DC power converter

■ Quick Reference Data

Item	General Specification		
Series No.	WF25P	WF20P	WF12P
Size code	2512 (6432)	2010 (5025)	1206 (3216)
Resistance Tolerance	± 1%, ± 5%		
Resistance Range	0Ω, 1Ω ~ 1MΩ		
TCR (ppm/°C)	± 100 ppm/°C		
Max. dissipation @ T _{amb} =70°C	2 W	1 W	1/2 W
Max. Operation Voltage (DC or RMS)	300V	200V	200V
Climatic category (IEC 60068)	55/155/56		

Note:

1. This is the maximum voltage that may be continuously supplied to the resistor element, see "IEC publication 60115-8"
2. Max. Operation Voltage : So called RCWV (Rated Continuous Working Voltage) is determined by $RCWV = \sqrt{\text{Rated Power} \times \text{Resistance Value}}$ or Max. RCWV listed above, whichever is lower.
3. 2W loading with total solder-pad and trace size of 300 mm²
4. Lead free product is upon customer requested.
5. 0Ω maximum resistance R_{max} < 15mΩ and rated current < 4Amp

■ Physical Dimensions

Unit: mm

	WF25P	WF20P	WF12P
L	6.30 ± 0.20	5.00 ± 0.20	3.10 ± 0.15
W	3.10 ± 0.20	2.50 ± 0.20	1.60 ± 0.15
T	0.60 ± 0.15	0.60 ± 0.10	0.55 ± 0.10
Tt	0.60 ± 0.25	0.60 ± 0.25	0.50 ± 0.25
Tb	1.80 ± 0.25	0.60 ± 0.25	0.50 ± 0.25

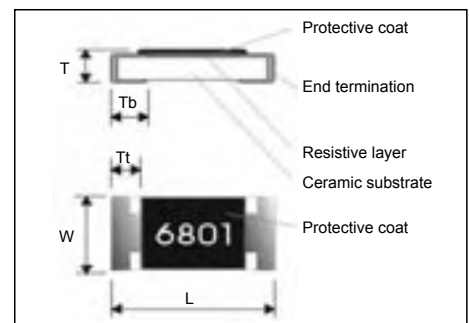

■ Quick Reference Data

Item	General Specification		
Series No.	WW25P	WW20P	WW12P
Size code	2512 (6432)	2010 (5025)	1206 (3216)
Resistance Tolerance	± 1%, ± 5%		
Resistance Range	0.100Ω ~ 0.976Ω		
TCR (ppm/°C)	± 100 ppm/°C		
Max. dissipation @ T _{amb} =70°C	2 W	1 W	1/2 W
Max. Operation Voltage (DC or RMS)	300V	200V	200V
Climatic category (IEC 60068)	55/155/56		

Note:

1. This is the maximum voltage that may be continuously supplied to the resistor element, see "IEC publication 60115-8"
2. Max. Operation Voltage : So called RCWV (Rated Continuous Working Voltage) is determined by $RCWV = \sqrt{\text{Rated Power} \times \text{Resistance Value}}$ or Max. RCWV listed above, whichever is lower.
3. 2W loading with total solder-pad and trace size of 300 mm²
4. Lead free product is upon customer requested.

■ Physical Dimensions

Unit: mm

	WW25P	WW20P	WW12P
L	6.30 ± 0.20	5.00 ± 0.20	3.10 ± 0.15
W	3.10 ± 0.20	2.50 ± 0.20	1.60 ± 0.15
T	0.60 ± 0.15	0.60 ± 0.10	0.55 ± 0.10
Tt	0.60 ± 0.25	0.60 ± 0.25	0.50 ± 0.25
Tb	1.80 ± 0.25	0.60 ± 0.25	0.50 ± 0.25

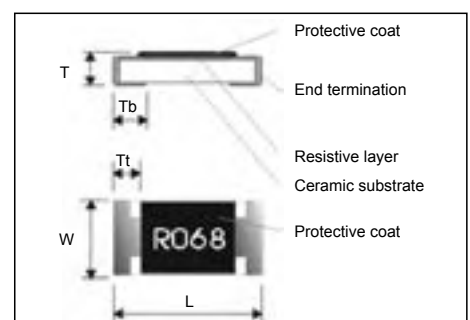

WFxxS Series of Surge Chip Resistors

Feature

1. Power rating and compact size
2. High reliability and stability
3. Reduced size of final equipment
4. Surge protection

Quick Reference Data

Item	General Specification		
Series No.	WF25S	WF20S	WF12S
Size code	2512 (6432)	2010 (5025)	1206 (3216)
Resistance Tolerance	±5%, ±10%, ±20%, (E24)		
Resistance Range	10Ω ~ 1MΩ		
TCR (ppm/°C)	± 100 ppm/°C		
Max. dissipation @ T _{amb} =70°C	1 W	1/2 W	1/4 W
Max. Operation Voltage (DC or RMS)	200V	200V	200V
Max. Overload Voltage (DC or RMS)	400V	400V	400V
Climatic category (IEC 60068)	55/125/56		

Note:

1. This is the maximum voltage that may be continuously supplied to the resistor element, see "IEC publication 60115-8"
2. Max. Operation Voltage : So called RCWV (Rated Continuous Working Voltage) is determined by $RCWV = \sqrt{\text{Rated Power} \times \text{Resistance Value}}$ or Max. RCWV listed above, whichever is lower.

Physical Dimensions

Unit: mm

	WF25S	WF20S	WF12S
L	6.30 ± 0.20	5.00 ± 0.20	3.10 ± 0.15
W	3.10 ± 0.20	2.50 ± 0.20	1.60 ± 0.15
T	0.60 ± 0.15	0.60 ± 0.10	0.55 ± 0.10
Tt	0.60 ± 0.25	0.60 ± 0.25	0.50 ± 0.25
Tb	0.60 ± 0.25	0.60 ± 0.25	0.50 ± 0.25

Application

1. Power supply
2. Measurement instrument
3. Automotive industry
4. Medical or Military equipment

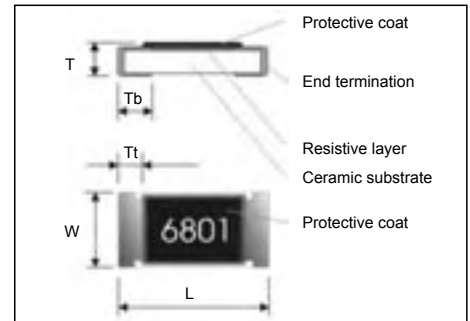
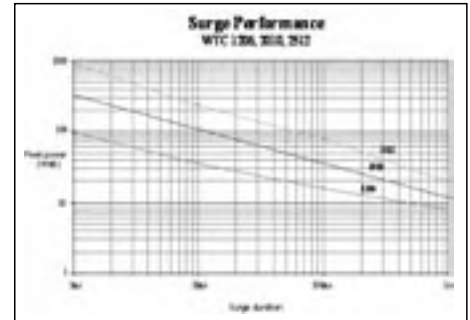

Precision Chip Resistors

Narrow Tolerance WFxxH Series

Quick Reference Data

Series No.	WF12H	WF08H	WF06H	WF04H
Size code	1206 (3216)	0805 (2012)	0603 (1608)	0402 (1005)
Resistance Tolerance	±0.5%, ±0.1%			
Resistance Range	10Ω ~ 1MΩ (E96+E24 series)			
TCR (ppm/°C) 10MΩ≤R≤1MΩ	≤ ± 100 ppm/°C			≤ ± 200 ppm/°C
Max. dissipation @ T _{amb} =70°C	1/4 Watt	1/8 Watt	1/10 Watt	1/16 Watt
Max. Operation Voltage (DC or RMS)	200V	100V	50V	50V
Climatic category (IEC 60068)	55/155/56			
Basic Specification	JIS C 5201-1 / IEC 60115-1			

(Detail specification please refer to specific data sheets)

Narrow Tolerance WFxxT Series

Quick Reference Data

Series No.	WF12T	WF08T	WF06T	WF04T
Size code	1206 (3216)	0805 (2012)	0603 (1608)	0402 (1005)
Resistance Tolerance	±0.5%, ±0.1%			
TCR (ppm/°C)	≤ ± 50 ppm/°C			
Max. dissipation @ T _{amb} =70°C	1/8 Watt	1/10 Watt	1/16 Watt	1/16 Watt
Max. Operation Voltage (DC or RMS)	200V	100V	50V	50V
Climatic category (IEC 60068)	55/155/56			
Basic Specification	JIS C 5201-1 / IEC 60115-1			

(Detail specification please refer to specific data sheets)

Narrow Tolerance WFxxU Series

Quick Reference Data

Series No.	WF12U	WF08U	WF06U	WF04U
Size code	1206 (3216)	0805 (2012)	0603 (1608)	0402 (1005)
Resistance Tolerance	±0.5%, ±0.1%			
TCR (ppm/°C)	≤ ± 25 ppm/°C			
Max. dissipation @ T _{amb} =70°C	1/8 Watt	1/10 Watt	1/16 Watt	1/16 Watt
Max. Operation Voltage (DC or RMS)	200V	100V	50V	50V
Climatic category (IEC 60068)	55/155/56			
Basic Specification	JIS C 5201-1 / IEC 60115-1			

(Detail specification please refer to specific data sheets)

■ Test and Requirements

■ For WR Series, WA Series, and WT Series

Test	Procedure / Test Method	Requirements	
		Resistor	0Ω
DC resistance Clause 4.5	DC resistance Values measured at the test voltages specified below : <10Ω @ 0.1V, <100Ω @ 0.3V, <1KΩ @ 0.1V, <10KΩ @ 3V, <100KΩ @ 10V, <1MΩ @ 25V, <10MΩ @ 30V	Within the specified tolerance	< 50m Ω
Temperature Coefficient of Resistance (T.C.R) Clause 4.8	Natural resistance change per change in degree centigrade. $\frac{R_2 - R_1}{R_1 (t_2 - t_1)} \times 10^6 \text{ (ppm/}^\circ\text{C)}$ t ₁ : 20°C+5°C-1°C R1 : Resistance at reference temperature R2 : Resistance at test temperature	Refer to "QUICK REFERENCE DATA"	N / a
Short Time Overload (S.T.O.L) Clause 4.13	Permanent resistance change after a 5second application of a voltage 2.5 times RCWV or the maximum overload voltage specified in the above list, whichever is less.	Δ R/R max. ± (2%+0.10Ω)	< 50m Ω
Resistance to Solder Heat (R.S.H) Clause 4.18	Un-mounted chips completely immersed for 10±1second in a solder bath at 270°C±5°C	Δ R/R max. ± (%+0.05Ω) no visible damage	< 50m Ω
Solderability Clause 4.17	Un-mounted chips completely immersed for 2±0.5second in a solder bath at 235°C±5°C	95% coverage min., good tinning and no visible damage	
Temperature Cycling Clause 4.19	30 minutes at -55°C±3°C, 2~3 minutes at 20°C+5°C-1°C, 30 minutes at +155°C±3°C, 2~3 minutes at 20°C+5°C-1°C, total 5 continuous cycles	Δ R/R max. ± (1%+0.05Ω)	< 50m Ω
Damp Heat (Load life in humidity) Clause 4.24	1000+48/-0 hours; 1.5hours ON, 0.5hours OFF at RCWV in a humidity chamber controlled 40±2°C, 90~95% RH	10Ω≤R<1MΩ : Δ R/R max. ± (3%+0.10Ω) R<10Ω, R≥1MΩ : Δ R/R max. ± (5%+0.10Ω)	< 50m Ω
Load Life (Endurance) Clause 4.25	1000+48/-0 hours; loaded with P _n or V _{max} ; 1.5 hours ON, 0.5 hours OFF	Ditto	
Bending strength Clause 4.33	Resistors mounted on a 90mm glass epoxy resin PCB(FR4), bending once 3mm for 10sec.	No visual damaged, Δ R/R max. ± (1%+0.05Ω)	< 50m Ω
Adhesion Clause 4.32	Pressurizing force: 5N, Test time: 10±1sec.	No remarkable damage or removal of the terminations	

■ For WWxxX series

Test	Procedure / Test Method	Requirement	
Temperature Coefficient of Resistance (T.C.R) Clause 4.8	Natural resistance change per change in degree centigrade. $\frac{R_2 - R_1}{R_1 (t_2 - t_1)} \times 10^6 \text{ (ppm/}^\circ\text{C)}$ t ₁ : 20°C+5°C-1°C R1 : Resistance at reference temperature R2 : Resistance at test temperature	Refer to "QUICK REFERENCE DATA"	
Short Time Overload (S.T.O.L) Clause 4.13	Permanent resistance change after a 5second application of a voltage 2.5 times RCWV or the maximum overload voltage specified in the above list, whichever is less.	Δ R/R max. ± (2%+0.005Ω) WW04X max ± (2%+0.010Ω)	
Resistance to Solder Heat (R.S.H) Clause 4.18	Un-mounted chips completely immersed for 10±1second in a solder bath at 270°C±5°C	no visible damage Δ R/R max. ± (1%+0.005Ω) WW04X max ± (1%+0.010Ω)	
Solderability Clause 4.17	Un-mounted chips completely immersed for 2±0.5second in a solder bath at 235°C±5°C	good tinning (>95% coverage) no visible damage	
Temperature Cycling Clause 4.19	30 minutes at -55°C±3°C, 2~3 minutes at 20°C+5°C-1°C, 30 minutes at +155°C±3°C, 2~3 minutes at 20°C+5°C-1°C, total 5 continuous cycles	no visible damage Δ R/R max. ± (1%+0.005Ω) WW04X max ± (1%+0.010Ω)	
Load Life (Endurance) Clause 4.25	70±2°C, 1000 hours, loaded with RCWV or V _{max} , 1.5 hours on and 0.5 hours off	Δ R/R max. ± (3%+0.005Ω) WW04X max ± (5%+0.010Ω)	
Load Life in Humidity Clause 4.24	1000 hours, at rated continuous working voltage in humidity chamber controller at 40°C±2°C and 90~95% relative humidity, 1.5hours on and 0.5 hours off	Δ R/R max. ± (3%+0.005Ω) WW04X max ± (5%+0.010Ω)	
Bending strength Clause 4.33	Resistors mounted on a 90mm glass epoxy resin PCB(FR4); bending : 2 mm, once for 10 seconds	Δ R/R max. ± (1%+0.005Ω) WW04X max ± (1%+0.010Ω)	
Adhesion Clause 4.32	Pressurizing force: 5N, Test time: 10±1sec.	No remarkable damage or removal of the terminations	

■ Packing on Tape and Reel

■ Paper Tape Specifications for WR, WF, WW Series and WA, WT Series

Unit: mm

Component Size / Series	W	F	E	P0	ØD
1206, 0805, 0603, 0402, WA06X, WA06T, WA04X, WA04Y, WA04P, WT04X	8.00 ± 0.30	3.50 ± 0.20	1.75 ± 0.10	4.00 ± 0.10	Ø1.50 ^{+0.1} _{-0.0}
WA06W	12.0 ± 0.10	5.50 ± 0.05			
WR02W	8.00 ± 0.20	3.50 ± 0.05			

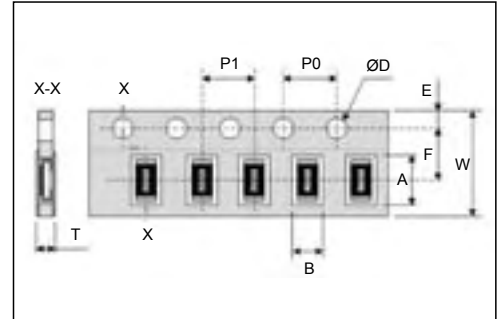

Component Size / Series	A	B	P1	T
1206 (3216), WA06X, WA06T	3.60 ± 0.20	2.00 ± 0.20	4.00 ± 0.10	Max. 1.0
0805 (2012)	2.40 ± 0.20	1.65 ± 0.20		0.65 ± 0.05
0603 (1608)	1.90 ± 0.20	1.10 ± 0.20		0.40 ± 0.05
0402 (1005)	1.20 ± 0.10	0.70 ± 0.10	2.00 ± 0.10	0.40 ± 0.05
WA04X	2.20 ± 0.20	1.20 ± 0.20	2.00 ± 0.05	Max. 0.6
WA04Y, WA04P	1.15 ± 0.10	1.15 ± 0.10	2.00 ± 0.05	0.45 ± 0.05
WT04X	3.45 + 0.2/-0	1.85 + 0.2/-0	4.00 ± 0.10	0.85 ± 0.05
WA06W	4.20 + 0.2/-0	1.80 + 0.2/-0	4.00 ± 0.10	0.65 ± 0.05
WR02X	0.67 ± 0.05	0.37 ± 0.05	2.00 ± 0.05	0.45 ± 0.05

■ Plastic Tape Specifications for WR, WF, WW Series of Chip-R

Unit: mm

Component Size	2512 (6432)	2010 (5025)	1218 (3248)
A	6.90 ± 0.20	5.50 ± 0.20	3.55 ± 0.30
B	3.60 ± 0.20	2.80 ± 0.20	4.90 ± 0.20
W	12.00 ± 0.30		
F	5.50 ± 0.1		
E	1.75 ± 0.10		
P1	4.00 ± 0.10		
P0	4.00 ± 0.10		
ØD	Ø1.50 ^{+0.1} _{-0.0}		
T	Max. 1.2		

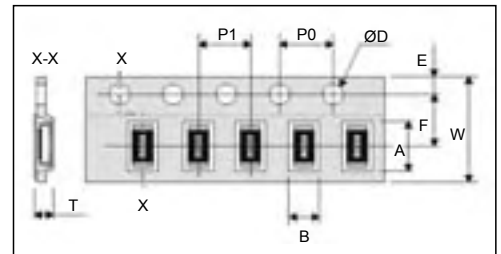

■ Plastic Tape Specifications for WR, WF, WW Series of Chip-R

Unit: mm

Reel / Tape	A	B	C	D
7" reel for 8mm tape	Ø178.0 ± 0.2	Ø60.0 ± 1.0	13.0 ± 0.2	9.0 ± 0.50
7" reel for 12mm tape				12.4 ± 1.00
10" reel for 8mm tape	Ø254.0 ± 2.0	Ø100.0 ± 1.0	13.0 ± 0.2	9.0 ± 0.50
10" reel for 12mm tape	Ø254.0 ± 2.0	Ø100.0 ± 1.0	13.0 ± 0.2	14.0 ± 0.2
13" reel for 8mm tape	Ø330.0 ± 2.0	Ø100.0 ± 1.0	13.0 ± 0.2	9.0 ± 0.50

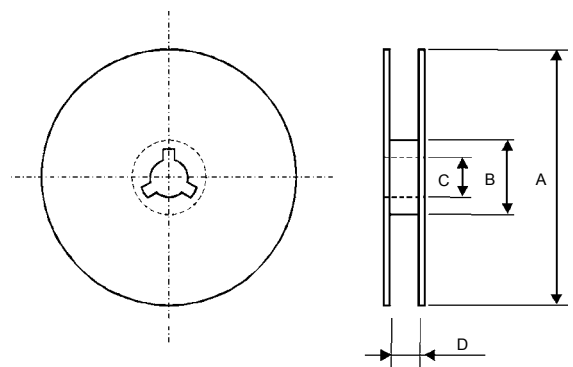

■ Paper Tape Specifications for WR, WF, WW Series and WA, WT Series

Unit: mm

Component Size / Series	Q'ty per reel	Reel diameter
0603, 0805, 1206	1,000 pcs	4" reel
1210, 1206, 0805, 0603, WA06X, WA06T, WT04X	5,000 pcs	7" reel
0402, WA04X, WA04Y, WA04P	10,000 pcs	7" reel
0201	15,000 pcs	7" reel
WA06X	5,000 pcs	7" reel
2512, 2010	4,000 pcs	7" reel
1218	3,000 pcs	10" reel
1206, 0805, 0603, WA06X, WA06T	10,000 pcs	10" reel
0402, WA04X, WA04Y	20,000 pcs	10" reel
2010, 2512	8,000 pcs	10" reel
0402	70,000 pcs	13" reel
WA04X, WA04Y	40,000 pcs	13" reel
1206, 0805, 0603	20,000 pcs	13" reel
2010, 2512	16,000 pcs	13" reel

Footprint Design

Footprint Design for WRxx Series, WFxx Series, WWxx Series :

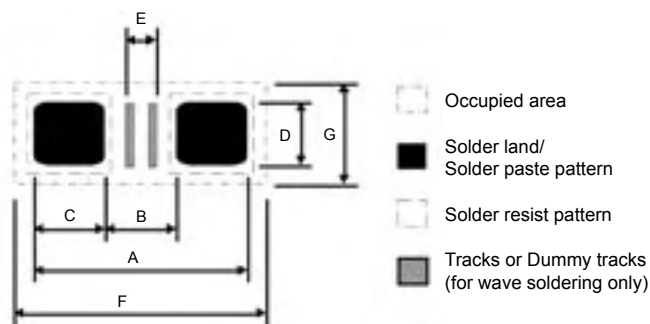

Unit: mm

Size	Reflow Soldering							Processing remarks	Placement Accuracy
	A	B	C	D	E	F	G		
0201	0.75	0.30	0.30	0.30	0.20	1.10	0.50	IR or hot plate soldering	± 0.05
0402	1.50	0.50	0.50	0.60	0.10	1.90	1.00		± 0.15
0603	2.10	0.90	0.60	0.90	0.50	2.35	1.45		± 0.25
0805	2.60	1.20	0.70	1.30	0.75	2.85	1.90		± 0.25
1206	3.80	2.00	0.90	1.60	1.60	4.05	2.25		± 0.25
1218	3.80	2.00	0.90	4.80	1.40	4.20	5.50		± 0.25
2010	5.60	3.80	0.90	2.80	3.40	5.85	3.15		± 0.25
2512	7.00	3.80	1.60	3.50	3.40	7.25	3.85		± 0.25
Size	Wave Soldering							Processing number & Dimensions of dummy tracks	Placement Accuracy
	A	B	C	D	E	F	G		
0603	2.70	0.90	0.90	0.80	0.15	3.40	1.90	1 x (0.15 x 0.80)	± 0.25
0805	3.40	1.30	1.05	1.30	0.20	4.30	2.70	1 x (0.20 x 1.30)	± 0.25
1206	4.80	2.30	1.25	1.70	1.25	5.90	3.20	3 x (0.25 x 1.70)	± 0.25
1218	4.80	2.30	1.25	4.80	1.30	5.90	5.60	3 x (0.25 x 4.80)	± 0.25
2010	6.30	3.50	1.40	2.50	3.00	7.00	3.60	3 x (0.75 x 2.50)	± 0.25
2512	8.50	4.50	2.00	3.20	3.00	9.00	4.30	3 x (1.00 x 3.20)	± 0.25

Footprint Design for Array Resistor/Attenuator :

Unit: mm

Symbol	0603*4 array	0402*4 array	WA04Y, WA04P	WA06W
A	2.85+0.10/ -0.05	1.80+0.15/ -0.05	1.20 ± 0.05	3.85+0.20/ -0.05
B	0.45 ± 0.05	0.30 ± 0.05	0.40 +0/ -0.05	0.28 +0/ -0.05
D	0.80 ± 0.10	0.50 ± 0.1	0.50 ± 0.05	1.00 +0.10/ -0.20
P	0.80	0.50	0.65	0.50
F	3.10 ± 0.30	2.00 +0.40/ -0.20	1.50 +0.20/ -0.10	3.20 ± 0.40

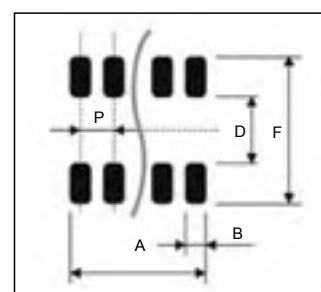

Footprint Design for 10P8R Network Resistor :

Unit: mm

Symbol	WT04X
W1	0.35 ± 0.05
W2	0.50 ± 0.05
H2	0.80 ± 0.10
P1	0.70 ± 0.05
P2	0.65 ± 0.05
A	3.20 ± 0.10
F	2.80 + 0.40 / - 0.20

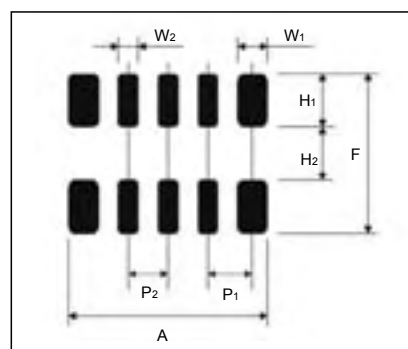

■ Storage and Handling Conditions:

1. Products are recommended to be used up within one year. Check solderability in case shelf life extension is needed.
2. To store products with following condition:
 - Temperature : 5 to 40°C
 - Humidity : 20 to 70% relative humidity
3. Caution:
 - a. Don't store products in a corrosive environment such as sulfide, chloride gas, or acid. It may cause oxidization of electrode, which easily be resulted in poor soldering.
 - b. To store products on the shelf and avoid exposure to moisture.
 - c. Don't expose products to excessive shock, vibration, direct sunlight and so on.

■ Recommendation of Soldering Profile:

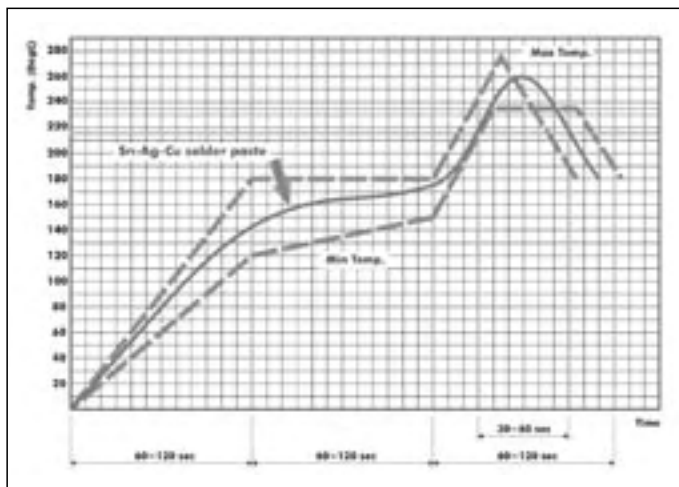

Figure. IR reflow soldering profile for SMT process with SnAgCu series solder paste.

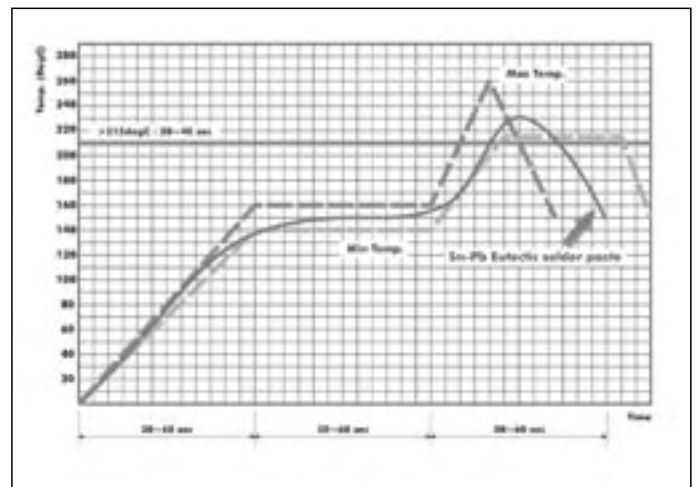

Figure. IR reflow soldering profile for SMT process with eutectic SnPb solder paste.

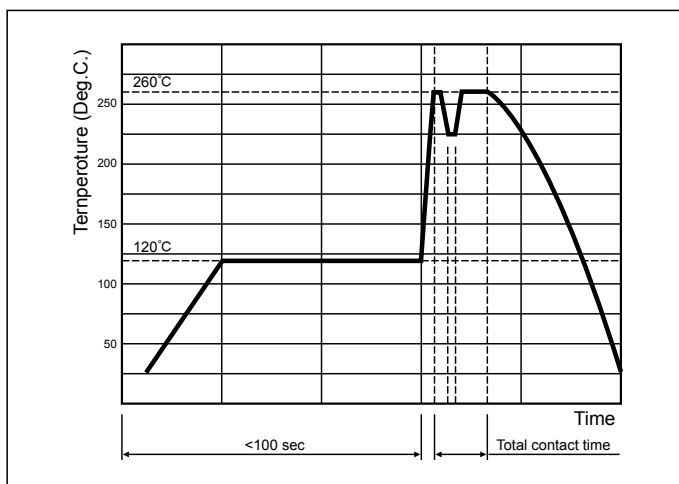

Figure. Wave soldering

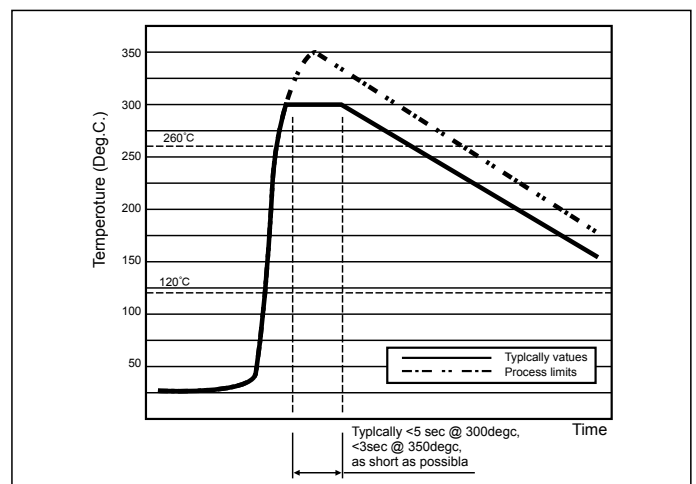

Figure. Manual soldering (soldering gun)