

3M™ Pak 100 4-Wall Header

.100" × .100" Low Profile, Straight and Right Angle, High Temp Option

2500 Series



- Low profile, space saving design
- Socket compatibility for current design validation
- Center slot polarization prevents mis-insertions and reduces insertion time
- Dual slot polarization means broader compatibility with competitive polarization designs
- Optional retainer clamp for locking sockets in place and increasing connection reliability in vibration-prone environments
- Optional snap-in latches available
- Optional polarizing post available
- Exposed solder tails (on right angle version) provide ease of cleaning and reduced repair costs

Date Modified: May 30, 2003

TS-0770-11
Sheet 1 of 3

Physical

Insulation
Material: Glass Filled Polyester (PBT)
Glass Filled Polyester (PCT) (High Temp Option)
Flammability: UL 94V-0
Color: Gray
Beige (High Temp Option)

Contact
Material: Copper Alloy

Plating
Underplate: 100 μ" [2.54 μm] Nickel — QQ-N-290, Class 2
Wiping Area: Gold — MIL-G-45204, Type II, Grade C
Solder Tails: 200 μ" [5.08 μm] 60/40 Tin Lead — MIL-P-81728
Wrap Tails: Gold Flash (Normal Temp Only)

Marking: 3M Logo, and Orientation Triangle

Electrical

Current Rating: 2 A
Insulation Resistance: $>1 \times 10^9 \Omega$ at 500 Vdc
Withstanding Voltage: 1000 Vrms at Sea Level

Environmental

Temperature Rating: -55°C to +105°C
Processing: Maximum 235°C, with 90 seconds over 215°C (High Temp Option)

UL File No.: E68080

3M™ Pak 100 4-Wall Header

.100" × .100" Low Profile, Straight and Right Angle, High Temp Option

2500 Series

Tail	Dim E	Pin Cross Section			Dim G ± .003
		Dimension F	Diagonals	Corner Radii	
X2	.112 [2.84]	.0245 ± .0005 [0.622]	.028 ± .001 [0.71]	.0075 Ref [0.191]	.035 [0.89] (See Note 2)
03	.155 [3.94]	.0245 ± .0005 [0.622]	.028 ± .001 [0.71]	.0075 Ref [0.191]	.035 [0.89]
05	.61 Ref [15.5]	.0250 ± .002 [0.635]	.035 ± .003 [0.90]	.003 Max [0.08]	.045 [1.14]

Pin Qty	Dimensions		Polarizing Notches
	A	B	
10	.788 [20.02]	.708 [17.98]	B C
14	.988 [25.10]	.908 [22.06]	B C D E
16	1.088 [27.64]	1.008 [25.60]	A B C D E
20	1.288 [32.72]	1.208 [30.68]	A B C D E
24	1.488 [37.80]	1.408 [35.76]	A B C D E
26	1.588 [40.34]	1.508 [38.30]	A B C D E
30	1.788 [45.42]	1.708 [43.38]	A B C D E
34	1.988 [50.50]	1.908 [48.46]	A B C D E
40	2.288 [58.12]	2.208 [56.08]	A B C D E
50	2.788 [70.82]	2.708 [68.78]	A B C D E
60	3.288 [83.52]	3.208 [81.48]	A B C D E
64	3.488 [88.60]	3.408 [86.56]	A B C D E

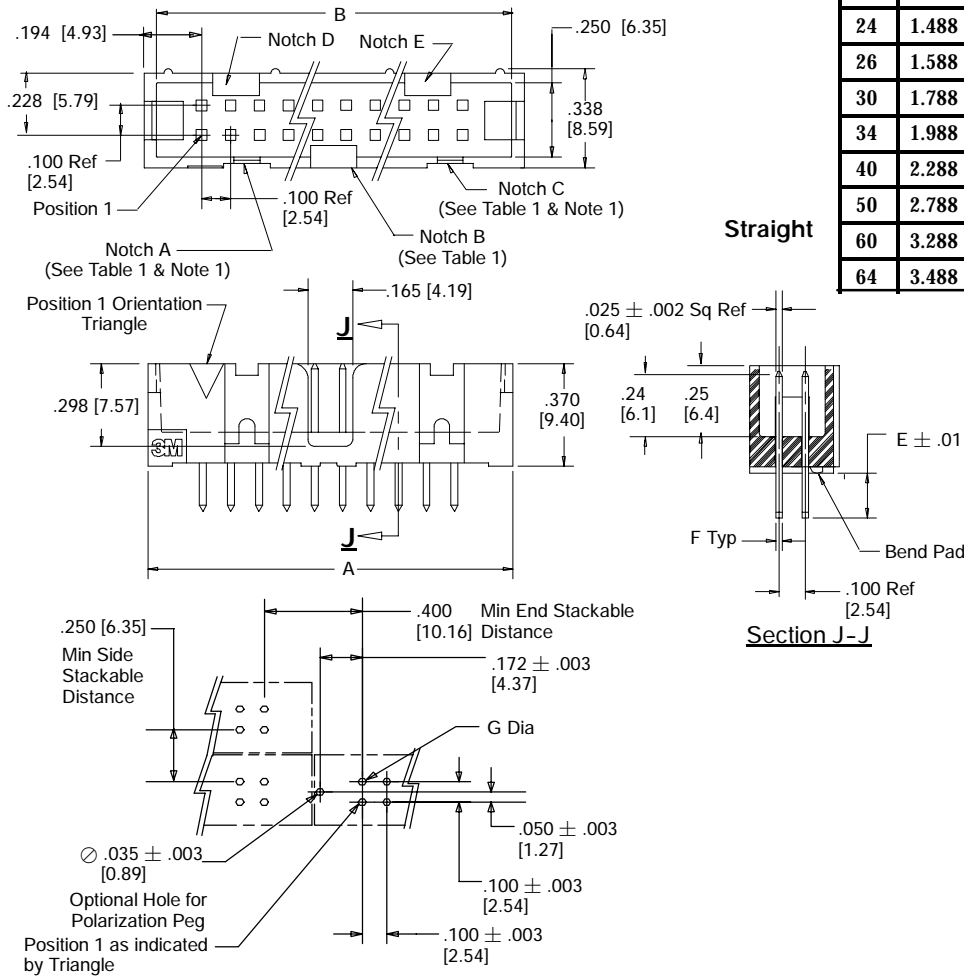

Recommended P.C. Board Hole Pattern

(Shown for mounting side of board.)

Notes:

- Notches "A" and "C" will accommodate 3M Polarizing Keys 3518.
- The recommended PCB hole size for the kinked tail positions on the .112" solder tail connector is .035" ± .002. Refer to TS-0972 for the positions kinked.



Inch [mm]			
Tolerance Unless Noted			
	.0	.00	.000
Inch	± .1	± .01	± .005

[] Dimensions for Reference Only

Ordering Information

X25XX-X0XXXX

Blank = Standard
N = High Temperature

Pin Quantity:
(See Table 1)

Bend Pad Option:
6 = Straight pin product with bend pad in High temp or normal plastics
7 = Straight pin product w/o bend pad in High temp only

Tail

02 = Solder Tails for .062 [1.57] Thick Board.
K2 = Kinked Solder Tails for .062 [1.57] Thick Board.
03 = Solder Tails for .094 to .125 [2.39 to 3.18] Thick Board.
05 = Wrap Tails for up to 3 Levels of Wire Wrap.
(Normal temp only)

Mating Plating Thickness:
Solder Tail Versions

UG = 15 μ" [0.38 μm]

UB = 30 μ" [0.76 μm]

Wrap Tail Versions

EB = 30 μ" [0.76 μm]

(Normal temp Only)

TS-0770-11
Sheet 2 of 3

3M™ Pak 100 4-Wall Header

.100" × .100" Low Profile, Straight and Right Angle, High Temp Option

2500 Series

Tail	Dim E	Pin Cross Section			Dim G ± .003
		Dimension F	Diagonals	Corner Radii	
X2	.112 [2.84]	.0245 ± .0005 [0.622]	.028 ± .001 [0.71]	.0075 Ref [0.191]	.035 [0.89] (See Note 2)
03	.155 [3.94]	.0245 ± .0005 [0.622]	.028 ± .001 [0.71]	.0075 Ref [0.191]	.035 [0.89]
05	.61 Ref [15.5]	.0250 ± .002 [0.635]	.035 ± .003 [0.90]	.003 Max [0.08]	.045 [1.14]

Pin Qty	Dimensions		Polarizing Notches
	A	B	
10	.788 [20.02]	.708 [17.98]	B C
14	.988 [25.10]	.908 [22.06]	B C D E
16	1.088 [27.64]	1.008 [25.60]	A B C D E
20	1.288 [32.72]	1.208 [30.68]	A B C D E
24	1.488 [37.80]	1.408 [35.76]	A B C D E
26	1.588 [40.34]	1.508 [38.30]	A B C D E
30	1.788 [45.42]	1.708 [43.38]	A B C D E
34	1.988 [50.50]	1.908 [48.46]	A B C D E
40	2.288 [58.12]	2.208 [56.08]	A B C D E
50	2.788 [70.82]	2.708 [68.78]	A B C D E
60	3.288 [83.52]	3.208 [81.48]	A B C D E
64	3.488 [88.60]	3.408 [86.56]	A B C D E

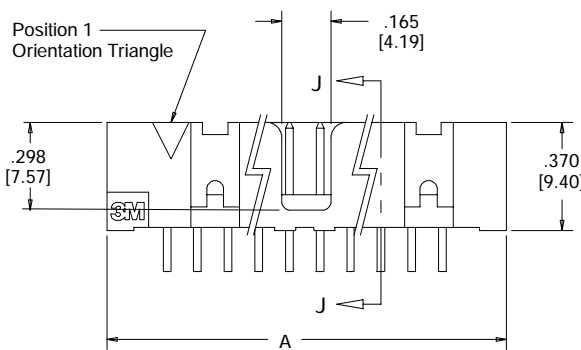
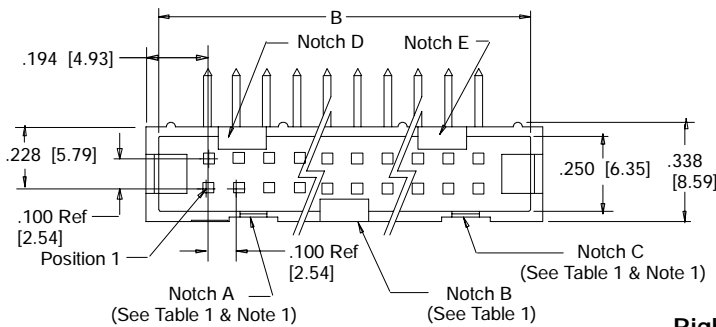

Right Angle

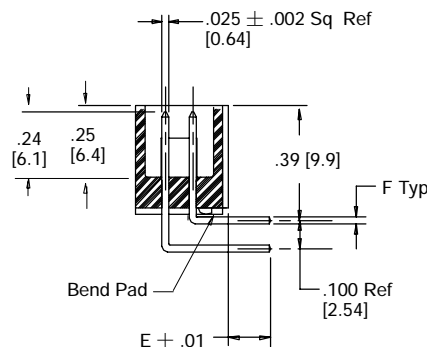

Section J-J

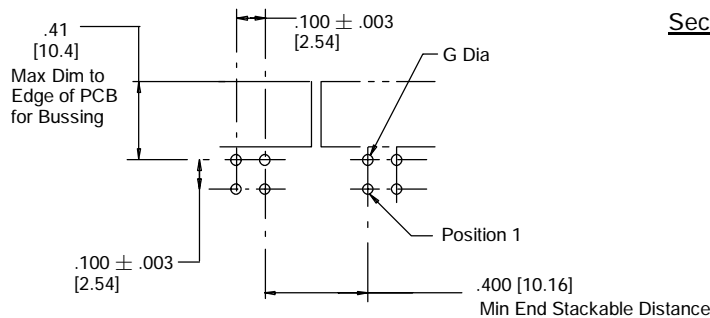

Recommended Mounting Hole Pattern

Notes:

- Notches "A" and "C" will accommodate 3M Polarizing Keys 3518.
- The recommended PCB hole size for the kinked tail positions on the .112" solder tail connector is .035" ± .002. Refer to TS-0972 for the position kinked.



Inch
[mm]

Tolerance Unless Noted			
	.0	.00	.000
Inch	± .1	± .01	± .005

[] Dimensions for Reference Only

Ordering Information

X25XX-50XXX

Blank = Standard
N = High Temperature

Pin Quantity:
(See Table 1)

Tail
02 = Solder Tails for .062 [1.57] Thick Board.
K2 = Kinked Solder Tails for .062 [1.57] Thick Board.
03 = Solder Tails for .094 to .125 [2.39 to 3.18] Thick Board.
05 = Wrap Tails for up to 3 Levels of Wire Wrap.
(Normal temp only)

Mating Plating Thickness:
Solder Tail Versions

UG = 15 μ" [0.38 μm]
UB = 30 μ" [0.76 μm]

Wrap Tail Versions

EB = 30 μ" [0.76 μm]
(Normal temp Only)

TS-0770-11
Sheet 3 of 3



Interconnect Solutions

<http://www.3M.com/interconnects/>

3M is a trademark of 3M Company.

For technical, sales or ordering information call

800-225-5373

Important Notice

All statements, technical information, and recommendations related to 3M's products are based on information believed to be reliable, but the accuracy or completeness is not guaranteed. Before using this product, you must evaluate it and determine if it is suitable for your intended application. You assume all risks and liability associated with such use. Any statements related to the product which are not contained in 3M's current publications, or any contrary statements contained on your purchase order shall have no force or effect unless expressly agreed upon, in writing, by an authorized officer of 3M.



Electronic and Interconnect Solutions Division

6801 River Place Blvd.
Austin, TX 78726-9000
www.3M.com/eisd

Warranty; Limited Remedy; Limited Liability.

This product will be free from defects in material and manufacture for a period of 1 year from the date of purchase. **3M MAKES NO OTHER WARRANTIES INCLUDING, BUT NOT LIMITED TO, ANY IMPLIED WARRANTY OF MERCHANTABILITY OR FITNESS FOR A PARTICULAR PURPOSE.** If this product is defective within the warranty period stated above, your exclusive remedy shall be, at 3M's option, to replace or repair the 3M product or refund the purchase price of the 3M product. **Except where prohibited by law, 3M will not be liable for any loss or damage arising from this 3M product, whether direct, indirect, special, incidental or consequential regardless of the legal theory asserted.**