

Quartz Crystal Units

1. Specifications:

Parameter	Symbol	Min.	Typ.	Max.	Unit
Oscillation Mode	Fundamental				
Cutting Mode	X +2°				
Nominal frequency	f_nom	-	32.768	-	KHz
Frequency tolerance at 25°C	f_tol	-20	-	20	x 10-6
Parabolic Coefficient	B	-	-	- 0.04	x 10-6 / °C ²
Load capacitance	CL	-	6	-	pF
Motional resistance (ESR)	R1	-	-	70	KΩ
Shunt capacitance	C0	-	-	2	pF
Motional capacitance	C1	-	-	-	fF
Maximum drive level	GL	-	1	-	μW
Operating temperature	T_use	-40	-	85	°C
Storage temperature	T_stg	-55	-	125	°C
Frequency aging	f_age	-3	-	3	x10-6 /year

2. Dimensions:

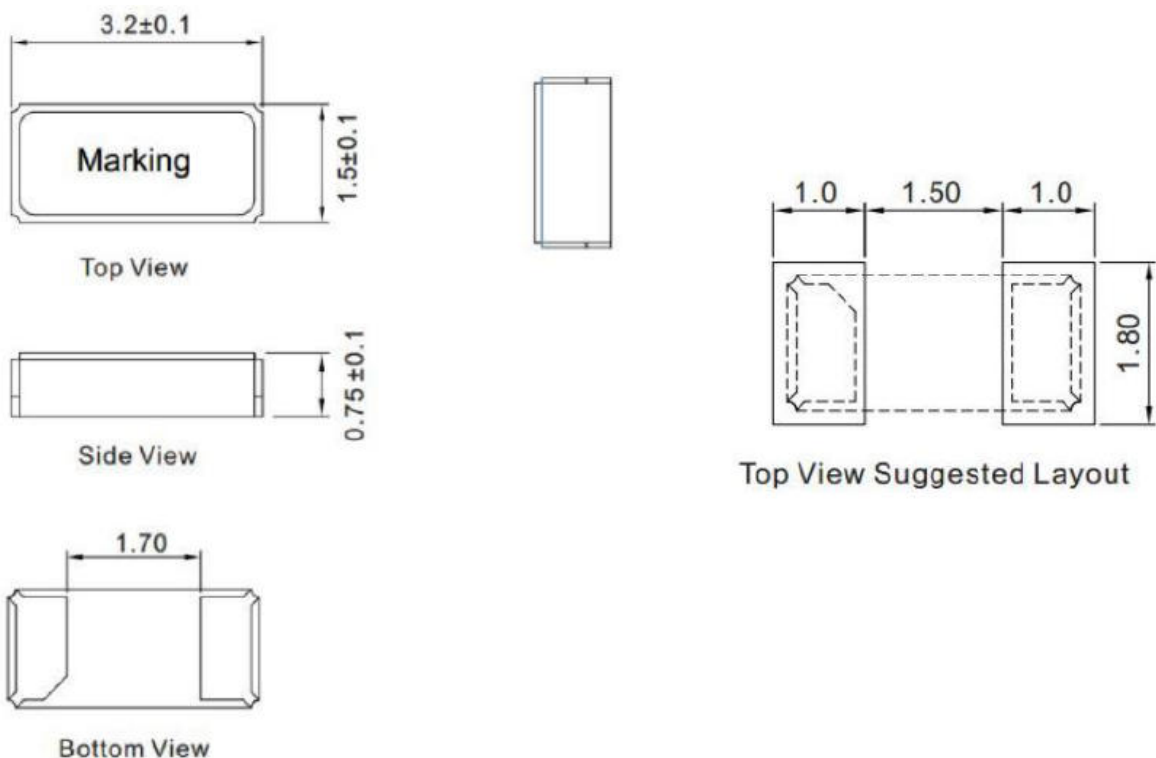

3. Taping specifications:

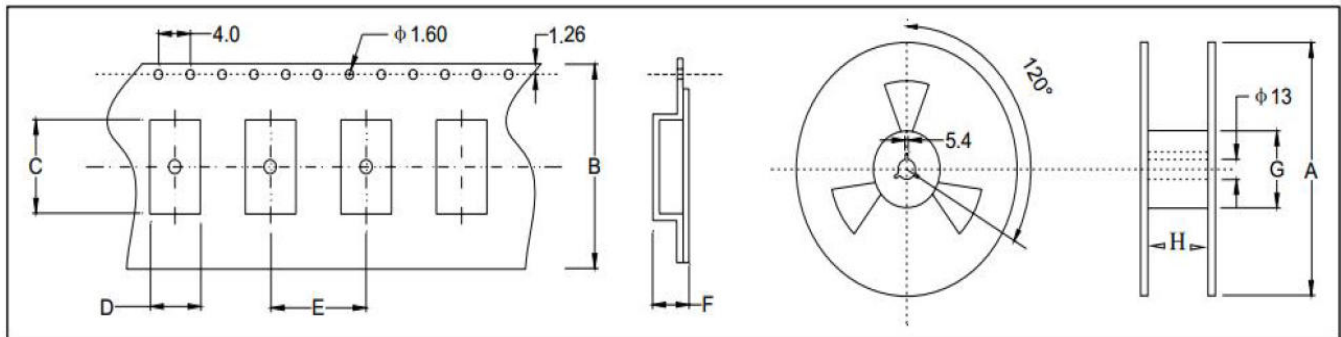

Size	A	B	C	D	E	F	G	H
SMD-3215	180±2.0	12.0±0.3	3.45±0.1	1.75±0.1	4.0±0.1	1.05±0.1	61.0±1.0	12.0±1.0

3000 pcs per reel

4. Reliability characteristic:

NO	Item	Condition	Reference	Specifications
6.1	Solderability	Solder bath temperature: 260°C, dwell time: 5seconds, Solder: 100% tin	IEC68-2-20:1979	A new uniform coating of solder shall cover a minimum of 95% of the surface being immersed.
6.2	Resistance to soldering heat	Solder temperature 260+/-5°C, Immersion time: 10 Solder bath composition: 100% tin	IEC68-2-58:1989	$\Delta F \leq \pm 5 \text{ppm}$
6.3	Vibration	The entire frequency range: 10Hz to 55Hz, Amplitude: 1.5mm This motion shall be applied for a period of 2 h in each of 3 mutually perpendicular axes (a total of 6h)	IEC 68-2-21:1992	$\Delta F \leq \pm 5 \text{ppm}$
6.4	Drop test	Drop from 75cm height on 3cm hard wooden board for 6 times	IEC68-2-32:1990	$\Delta F \leq \pm 5 \text{ppm}$
6.5	Cold Storage	The quartz crystal unit shall be stored at a temperature of -40+/-3°C for 1000 h. then it shall be subjected to standard atmospheric conditions for 1h after which measurement shall be made.	IEC68-2-6:1982	$\Delta F \leq \pm 5 \text{ppm}$

6.6	High temperature; High humidity storage(steady state)	The quartz crystal unit shall be stored at a temperature of 40+/-2°C with relative humidity of 95% for 1000h, then it shall be subjected to standard atmospheric conditions for 2h after which measurement shall be made.	IEC60068-2-1:1990	$\Delta F \leq \pm 5 \text{ppm}$												
6.7	Thermal shock	<p>The quartz crystal unit shall be subjected to 50 successive Change of temperature cycles. Each as shown in table below ,then it shall be subjected to standard atmospheric conditions for 1h after which measurement shall be made.</p> <table border="1" style="margin-left: auto; margin-right: auto;"> <thead> <tr> <th>NO</th> <th>Temperature</th> <th>Duration</th> </tr> </thead> <tbody> <tr> <td>1</td> <td>-40+/-3°C</td> <td>15minutes</td> </tr> <tr> <td>2</td> <td>105+/-2°C</td> <td>15minutes</td> </tr> <tr> <td>3</td> <td>Transition time</td> <td>Within 10 seconds</td> </tr> </tbody> </table>	NO	Temperature	Duration	1	-40+/-3°C	15minutes	2	105+/-2°C	15minutes	3	Transition time	Within 10 seconds	IEC68-2-14:1986	$\Delta F \leq \pm 5 \text{ppm}$
NO	Temperature	Duration														
1	-40+/-3°C	15minutes														
2	105+/-2°C	15minutes														
3	Transition time	Within 10 seconds														
6.8	Sealing	Helium leakage detector shall used to measure the leakage rate of gas through any faulty seal. Pressure: 500Kpa, duration: 120 minutes.	IEC68-2-3:1984	Leakage rate $\leq 1 \cdot 10^{-9} \text{ Pa.m}^3/\text{S}$												
6.9	High temperature; Life test	The quartz crystal unit shall be stored at a temperature of 105+/-3°C for 168h ,then it shall be subjected to standard atmospheric condition for 1h after which measurement shall be made.	IEC60068-2-2:1974	$\Delta F \leq \pm 5 \text{ppm}$												

4. Reflow profile:

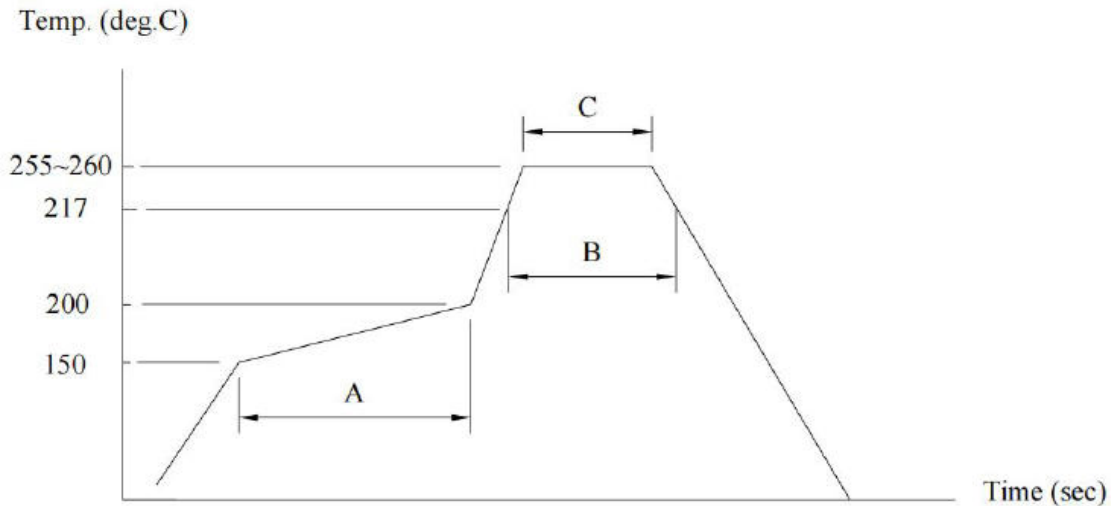

- (A)→Preheating area : 150~200°C, 60~120sec.
- (B)→Heating area : 217°C, 60~150sec.
- (C)→Peak temperature : 255~260°C, 30sec. Max.
- Ramp-up rate (217→260°C) : 3°C/sec. Max.
- Ramp-down rate (260→217°C) : 6°C/sec. Max.
- Time 25°C→260°C : 480sec. Max.
- Moisture Sensitivity Level : Level1

5. Disclaimer

Akyga passive reserves the right to make changes without notice to any product specification herein, to make corrections, modifications, enhancements or other changes. Akyga passive or anyone on its behalf assumes no responsibility or liability for any errors or inaccuracies. Data sheet specifications and its information contained are intended to provide a product description only. "Typical" parameters which may be included on Akyga passive data sheets and/ or specifications can and do vary in different applications and actual performance may vary over time. Akyga passive does not assume any liability arising out of the application or use of any product or circuit. Akyga passive products are not designed, intended or authorized for use in medical, life-saving implant or other applications intended for life-sustaining or other related applications where a failure or malfunction of component or circuitry may directly or indirectly cause injury or threaten a life without expressed written approval of Akyga passive. Customers using or selling Akyga passive components for use in such applications do so at their own risk and shall agree to fully indemnify Akyga passive and its subsidiaries harmless against all claims, damages and expenditures.