

Low Dropout Voltage Regulator

Primary characteristics		
Parameter	Value	Unit
Input voltage	1.5 ~ 8	V
Output voltage	1.1~3.4	V
Max. output current	400	mA

Features

- Output voltage accuracy within $\pm 2\%$
- Low quiescent current
- Low dropout voltage
- Short circuit protection
- Current limiting protection
- Standard fixed output voltage options: 1.1V~3.4V – Customized by every 0.1V step

Applications

- Radio control systems
- Cellphones, radiophones, digital cameras
- Bluetooth, wireless headsets

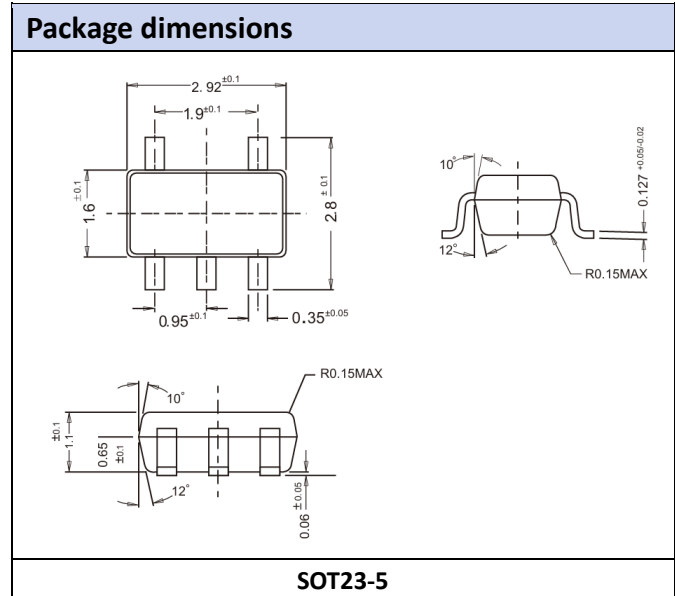

Absolute maximum ratings ($T_a=25^\circ\text{C}$)

Parameter	Value	Unit
Input voltage V_{IN}	-0.3 ~ +9	V
Maximum load current	450	mA
Power dissipation	400	mW
Thermal resistance junction to ambient	400	$^\circ\text{C}/\text{W}$
Operating ambient temperature	-40 ~ +85	$^\circ\text{C}$
Junction temperature	-40 ~ +125	$^\circ\text{C}$
Storage temperature range	-55 ~ +150	$^\circ\text{C}$
Lead temperature	260 $^\circ\text{C}$ for 10s	
ESD voltage HBM	3.5	kV

Recommended operating conditions ($T_a=25^\circ\text{C}$)

Parameter	Value	Unit
Supply voltage	1.5 ~ 8	V
Maximum output current	400	mA
Environment temperature	-40 ~ +85	$^\circ\text{C}$

Electrical characteristics
(V_{OUT} = 3.3V, C_{IN} = 1μF, C_{OUT} = 1μF, T_a = 25°C unless otherwise specified)

Parameter	Symbol	Test conditions	Min.	Typ.	Max.	Unit	
Input voltage	V _{IN}	-	1.5	-	8	V	
Output voltage accuracy	ΔV _{out}	I _{OUT} = 1mA	-2	-	+2	%	
Quiescent current	I _Q	V _{OUT} = 3.3V, I _{OUT} = 0	-	0.5	-	μA	
Shut-down current	I _{SHDN}	V _{EN} = 0V	-	-	1		
Dropout voltage	V _{DROP}	V _{OUT} = 3.3V, I _{OUT} = 100mA	-	180	-	mV	
		V _{OUT} = 3.3V, I _{OUT} = 200mA	-	400	-		
Line regulation	ΔV _{line}	V _{IN} = 2.7V ~ 5.5V, I _{OUT} = 1mA	-	0.01	0.15	%	
Load regulation	ΔV _{load}	V _{OUT} = 3.3V, 1mA < I _{OUT} < 300mA	-	200	-	mV	
Current limit	I _{LIM}	V _{IN} = V _{EN} = 4.5V	-	400	-	mA	
Short current	I _{SHORT}	V _{IN} = V _{EN} V _{OUT} short to GND with 1Ω	-	35	-		
EN input current	I _{EN}	V _{EN} = 0 ~ 5.5V	-	-	1	μA	
EN input threshold	Logic low	V _{IL}	V _{IN} = 5.5V, V _{OUT} = 0mA	-	-	0.4	V
	Logic high	V _{IH}	V _{IN} = 5.5V, I _{OUT} = 1mA	1.2	-	V _{IN}	
Power supply rejection rate	PSSR	V _{IN} = 5V _{DC} +0.5V _{P-P} , f=1kHz, I _{OUT} = 10mA	-	60	-	dB	

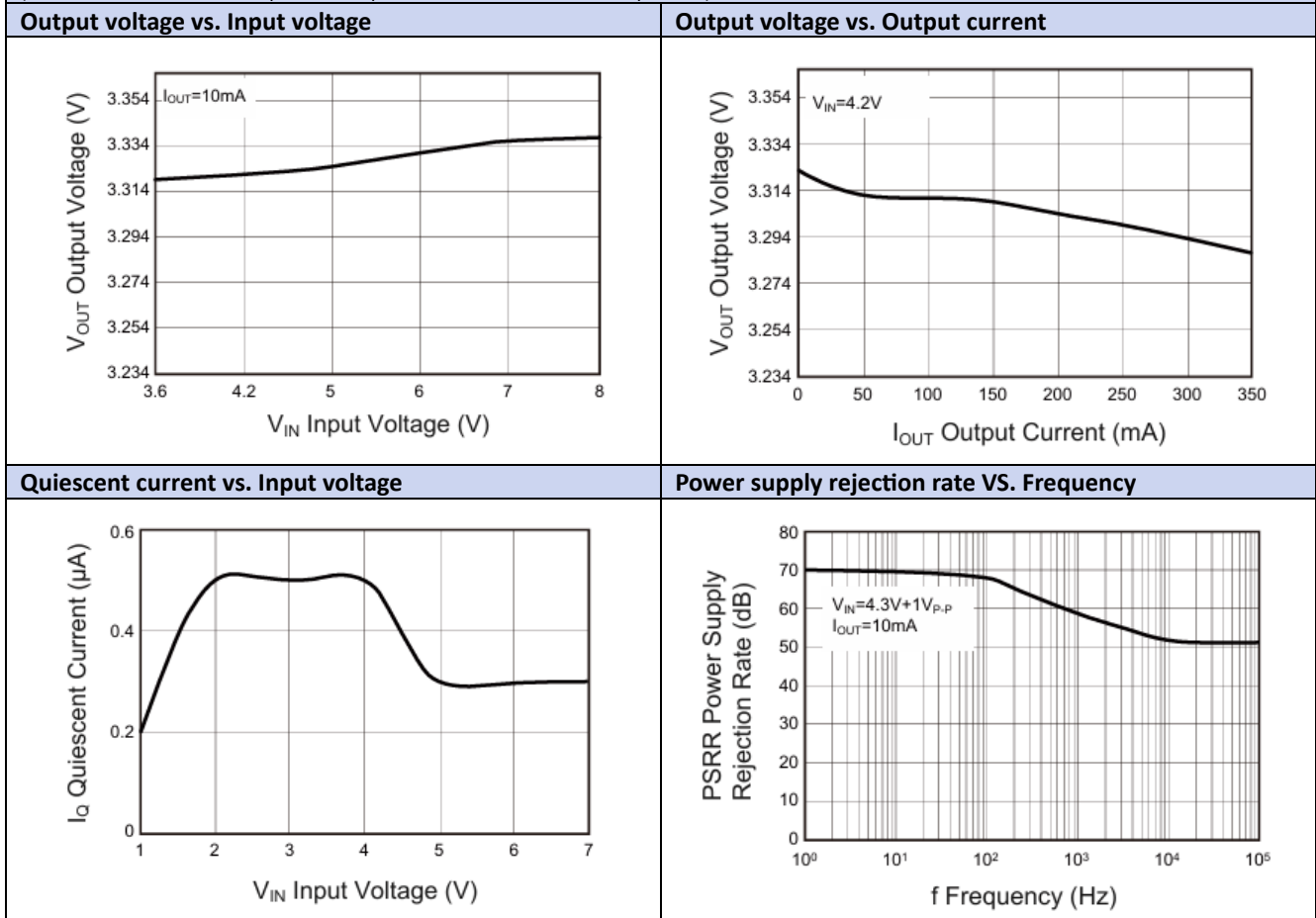
Typical electrical curves
(V_{IN} = 4.5V, V_{OUT} = 3.3 V, C_{IN} = 1 μF, C_{OUT} = 1 μF, T_a = 25°C unless otherwise specified)

Functional description
Input capacitor
A 1 μ F ceramic capacitor is recommended to connect between VIN and GND pins to decouple input power supply glitch and noise. The amount of the capacitance may be increased without limit. This input capacitor must be located as close as possible to the device to assure input stability and less noise. For PCB layout, a wide copper trace is required for both VIN and GND. The input capacitor should be at least equal to, or greater than, the output capacitor for good load transient performance.
Output capacitor
An output capacitor is required for the stability of the LDO. The recommended output capacitance is from 1 μ F to 10 μ F. Equivalent Series Resistance (ESR) is from 5 m Ω to 500 m Ω , and temperature characteristics are X7R or X5R. Higher capacitance values help to improve load/line transient response. The output capacitance may be increased to keep low undershoot/overshoot. Place output capacitor as close as possible to OUT and GND pins.
ON/OFF input operation
EN pin is internally held low by a 1-M Ω resistor to GND. The regulator is turned on by setting the EN pin higher than V _{IH} threshold, and is turned off by pulling it lower than V _{IL} threshold. If this feature is not used, the EN pin should be tied to VIN for automatic startup.
Low quiescent current
Cellular phone baseband internal digital circuits typically operate all the time. That requires LDO to stay on all time. However, in the standby mode, the microprocessor consumer only around 100~300 μ A. Since the phone stays in standby for the longest percentage of time, using 0.5 μ A quiescent current LDO, instead of 100 μ A, saves 99.5 μ A. That means it can substantially extend the battery standby time and provide great power saving in portable and low power applications.
Current limit protection
When output current at the OUT pin is higher than current limit threshold or the OUT pin is short-circuiting to GND, the current limit protection will be triggered and clamp the output current to a pre-set level to prevent over-current and to protect the regulator from damage due overheating.
Thermal overload protection
When the temperature is too high, such as a short circuit in the output pins or a device with a very large load current and a large voltage drop, the internal thermal protection circuit will be triggered and will shut down the power supply MOSFET and prevent LDO damage. Once the excessive thermal conditions are eliminated and the temperature of device drops, the protection circuit will restore control of the power MOSFET and allow LDO to enter normal operation.

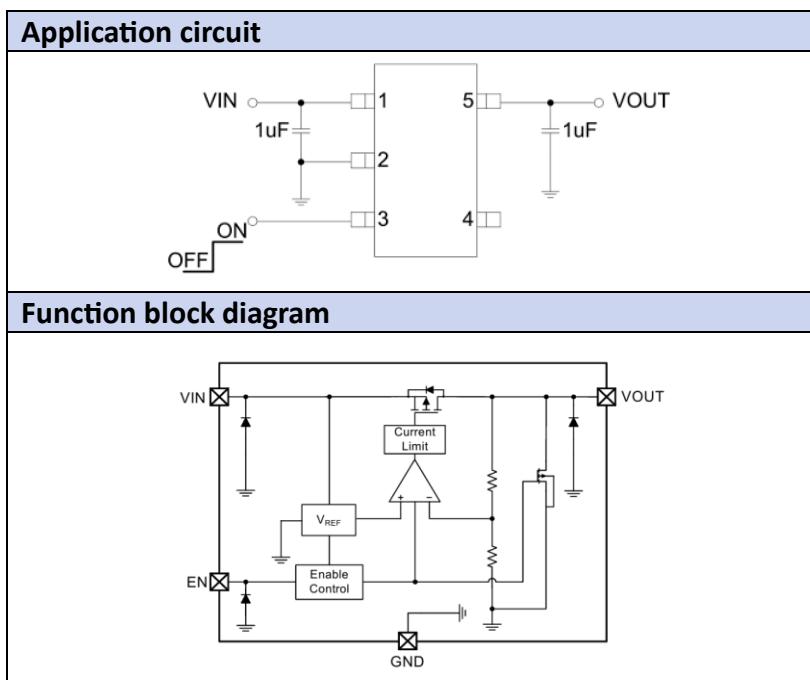

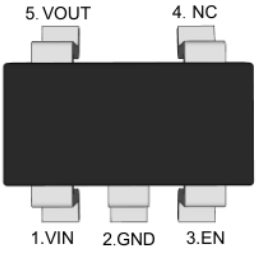
Pin configuration													
	<table border="1"> <thead> <tr> <th>Pin name</th> <th>Function</th> </tr> </thead> <tbody> <tr> <td>VIN</td> <td>Power input voltage</td> </tr> <tr> <td>GND</td> <td>Ground</td> </tr> <tr> <td>EN</td> <td>Chip enable (active high)</td> </tr> <tr> <td>NC</td> <td>Not connected</td> </tr> <tr> <td>VOUT</td> <td>Output voltage</td> </tr> </tbody> </table>	Pin name	Function	VIN	Power input voltage	GND	Ground	EN	Chip enable (active high)	NC	Not connected	VOUT	Output voltage
	Pin name	Function											
	VIN	Power input voltage											
	GND	Ground											
	EN	Chip enable (active high)											
	NC	Not connected											
VOUT	Output voltage												

Ordering information			
Product model	Package type	Packing	Packing quantity
AK9400-1.1KE ~ AK9400-3.4KE	SOT-23-5	Tape	3000 pcs / reel

Disclaimer

Akyga semi reserves the right to make changes without notice to any product specification herein, to make corrections, modifications, enhancements or other changes. Akyga semi or anyone on its behalf assumes no responsibility or liability for any errors or inaccuracies. Data sheet specifications and its information contained are intended to provide a product description only. "Typical" parameters which may be included on Akyga semi data sheets and/ or specifications can and do vary in different applications and actual performance may vary over time. Akyga semi does not assume any liability arising out of the application or use of any product or circuit. Akyga semi products are not designed, intended or authorized for use in medical, life-saving implant or other applications intended for life-sustaining or other related applications where a failure or malfunction of component or circuitry may directly or indirectly cause injury or threaten a life without expressed written approval of Akyga semi. Customers using or selling Akyga semi components for use in such applications do so at their own risk and shall agree to fully indemnify Akyga semi and its subsidiaries harmless against all claims, damages and expenditures.