



## Specification Approval Sheet

**Name : Battery Li-FePO4**

**Model : AKYGA IFR18650**

**SPEC : 28.8V 1600mAh**

**Number: IFR18650-9S1P-1.6M**

### Specification Modification Records

Modification Time	Descriptions	Issued Date	Approved By
	Release 1	2025-01-07	

Content

### 1. Scope

This specification is applied to Lithium-ion rechargeable battery pack which is manufactured by Akyga Battery.

### 2. Product Configuration

No.	Item Name	Specification	Qty	Remark
1	Li-ion Cell	IFR18650-1600mAh 3.2V	9	9S1P
2	PCM	CM13C1+TO252*2	1	
3	Connector	/		
4	Wire	Red wire UL3239-22AWG-150mm	1	P+
		Black wire UL3239-22AWG-150mm	1	P-

### 3. Product Dimension

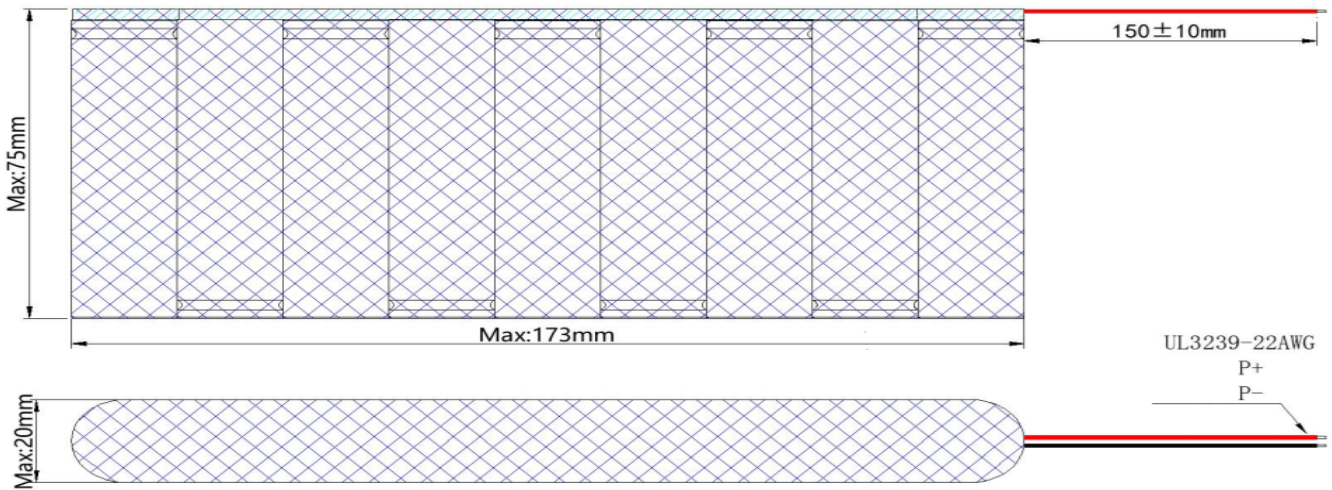

## 4.Product Specification

Table 1:

1:

No.	Item	Rated Performance		Remark
1	Rated Capacity	Typical	1600mAh	Discharge at 0.2C <sub>5</sub> A after standard charge fully.
		Minimum	1550mAh	
2	Nominal Voltage	28.8V		
3	OCV	> 27.9V		Shipment voltage
4	Voltage at end of Discharge	20.7V		Discharge cut-off voltage.
5	Charging Voltage	32.85 ± 0.05V		
6	AC (1KHz) Impedance New Cell Max.(mΩ)	≤ 400m Ω		
7	Standard Charge	Constant Current 0.5C <sub>5</sub> A Constant Voltage 32.85V 0.02C <sub>5</sub> A cut-off 0.5C <sub>5</sub> A                      32.85V 32.85V    0.02C <sub>5</sub> A		Charge time: Approx 4.0h.
8	Standard Discharge	Constant Current 0.2C <sub>5</sub> A end voltage 20.7V 0.2C <sub>5</sub> A                      20.7V		
9	Fast Charge	Constant Current 1C <sub>5</sub> A Constant Voltage 32.85V 0.02C <sub>5</sub> A cut-off 1C <sub>5</sub> A                      32.85V		Charge time : Approx 2.0h.
10	Fast Discharge	Constant Current 1C <sub>5</sub> A end voltage 20.7V		
11	Maximum Continuous Charge Current	1C <sub>5</sub> A		
12	Maximum Continuous Discharge Current	3C <sub>5</sub> A		
13	Operation Temperature Range	Charge: -20~60°C		60±25% RH. Bare Cell.
		Discharge: -50~80°C		
14	Storage Temperature	Less than 1 year: -5~25°C		60±25%RH.

	Range	1 : -5~25°C Less than 3 months: -20~25°C	
15	Storage Humidity Range	60±25%RH.	
16	Weight	Approx:/g	
17	Product Dimension	Length: Max173mm	
		Width: Max75mm	
		Thickness: Max20mm	

## 5.Product Performance Tes

### 5.1 Standard Testing Conditions

The test should be conducted with fresh battery within one week after shipment and the battery shall not be cycled more than five times. Unless otherwise defined, the test and measurement shall be done under temperature of  $23\pm 2^{\circ}\text{C}$  and relative humidity of 45~85%. Normally, the temperature and relative humidity will not affect the test results when they are at a range of temperature 15~30°C and humidity 25~85%RH

### 5.2 Measuring Instrument or Apparatus

#### 5.2.1 Dimension Measuring Instrument

The dimension measurement shall be implemented by instruments with equal or more precision scale of 0.01mm.

#### 5.2.2 Volt meter

Standard class specified in the national standard or more sensitive class having inner impedance more than 10kΩ/V

#### 5.2.3 Ammeter meter

Standard class specified in the national standard or more sensitive class. Total external resistance including ammeter and wire is less than 0.01Ω.

#### 5.2.4 Impedance Meter

Impedance shall be measured by a sinusoidal alternating current method(1kHz LCR meter).

**5.3 Standard Charge\Discharge**

5.3.1 Standard Charge

CC-CV

Test procedure and its criteria are referred as follows:

$0.5C_5A = 800mA$

Charge with  $0.5C_5A$  constant current until the battery reaches 32.85V. Then charge with voltage 32.85V until the charging current drops to  $0.02C_5A$ . The charge will be terminated and the battery shall be fully charged. Charge time is Approx 4.0h. The battery shall be with no permanent degradation when charged between  $-20\text{ }^\circ\text{C}$  and  $60\text{ }^\circ\text{C}$ .

5.3.2 Standard Discharge

$0.2C_5A = 320mA$

Battery shall be discharged at a constant current of  $0.2C_5A$  to 20.7V @  $23\pm 2\text{ }^\circ\text{C}$ .

**5.4 Appearance**

There shall be no such defects as flaw, crack, rust, leakage, which may adversely affect commercial value of battery.

**5.5 Initial Performance Test**

Table 2:

Item	Measuring Procedure	Requirements
(1) Retention Capability	After charge fully, store the battery for 28 days at $23\pm 2\text{ }^\circ\text{C}$ , then store 1 hours more, then discharge the battery at current of $0.2C_5A$ till 20.7V cut-off voltage.	Capacity $\geq 80\%$

**5.6 Discharge capacity at different temperatures**

Battery shall be charged per 5.3.1. and discharged @0.2C<sub>5</sub>A to 20.7 volts at different temperatures, the discharge capacities are as shown in below Table 3. The battery shall be stored for 3 hours at the test temperature before test. Each battery shall meet or exceed the discharge capacities as shown in below Table 3.

Discharge Temperature	-40°C	-20°C	25°C	60°C
Discharge Capacity (0.2C <sub>5</sub> A)	40%	75%	100%	95%

**5.7 Cycle Life and Leakage-Proof**

Table 4:

No.	Item	Criteria	Test Conditions
1	Cycle Life	Higher than 80% of the Typical Capacities of the battery	Carry out 2000 cycles charging/discharging: ◆ Charge: Standard Charge, per 5.3.1 ◆ Discharge: 1C <sub>5</sub> A to 20.7V ◆ Rest Time between charge/discharge:30min. ◆ Temperature:23±2°C
2	Leakage-Proof	No leakage (visual inspection)	After fully charged, store at 60±3°C,60±10%RH for 1 month.

**5.8 Mechanical Characteristics and Safety Test**

Item	Battery Condition	Test Method	Requirements
Over charge test	Fresh battery, Fully Charged	Discharge : 0.2 C <sub>5</sub> A to 20.7V Charge : 1.0 C <sub>5</sub> A charge to 41.4V, and maintain for 7 hours.	No explosion No fire
Over discharge test	Fresh battery, Fully Charged	Discharge at constant current 0.2 C <sub>5</sub> A to 0V,	No explosion no fire, no smoke
Heat shock test	Fresh battery, Fully Charged	Put the battery in hot box ,then heat up to 130°C in 1 minute, remain for 10 minutes.	No explosion No fire
Impact test	Fresh battery, Fully Charged	Impact between bar (15.8mm diameter) and 9.1Kg falling material (at a height of 6.1cm). Bar is laid across the center of the test sample.	No explosion No fire
Crush Test	Fresh battery, Fully Charged	Crush between two flat plates. Applied force is about 13kN(1.72Mpa) for 10min.	No explosion, No fire
Short Circuit test	Fresh battery, Fully Charged	Make short-circuited by connecting the (+) and (-) terminals of the battery with a copper wire having a maximum resistance load of 0.1Ω. Tests are to be conducted at room temperature (20±2°C).	No explosion, No fire. The surface of the battery shouldn't exceed 150°C
Rate test	Fresh battery, Fully Charged	0.5C/1C/3C charge & discharge.	

Low temperature discharge test	Fresh battery, Fully Charged	Put the battery at $-40^{\circ}\text{C}$ for 3h, then discharge at $0.2C_5A$ to $20.7V$ .	Discharge capacity $\geq 40\%$
Store for 4 hours $85^{\circ}\text{C}$	Fresh battery, Fully Charged	Charge the battery fully in standard charging way at ambient temperature ( $23 \pm 2^{\circ}\text{C}$ ) and store for 1 hour. Then put it into the constant temperature and humidity oven at $85 \pm 2^{\circ}\text{C}$ for 4 hours. Take it out and cool it for 2 hours at ( $23 \pm 2^{\circ}\text{C}$ ). And then test the thickness and capacity at $0.2C_5A$ when charge & discharge.	<p>The rate of swelling <math>\leq 10\%</math></p> <p>Remaining capacity <math>\geq 70\%</math> initial capacity</p> <p>Recovery capacity <math>\geq 80\%</math> initial capacity</p>
Vibration test	Fresh battery, Fully Charged	Vibrate the battery for 30 minutes per each three mutually perpendicular axis (X,Y,Z) after standard charge.	No rupture, no fire. No critical damage.
Drop test	Fresh battery, Fully Charged	Drop the battery from a height of 1m onto concrete board with 18~20mm thickness each one time from every direction after standard charge. Then discharge and charged at $1C$ 3 times, record the time of discharging.	No rupture, no fire. No critical damage. Discharge time $\geq 51\text{min}$



## 6. PCM Specification

**6.1 Using scope:** It applies to Li-ion Battery protection module for Akyga Battery.

**6.2 Battery capacity:** 1600mAh

**6.3 Environment request:** RoHS.

**6.4 Function description:** Over charge protection, Over discharge protection, Over current protection, Short circuit protection

**6.5 Electrical features:**

project	Parameter value			
	General temperature: 25°C			
Item	Min.	Type value	Max.	Unit
Over charge protection voltage	3.63	3.65	3.67	V
Over charge release voltage	4.10	3.55	4.20	V
Over discharge protection voltage	2.25	2.30	2.35	V
Over discharge release voltage	2.42	2.50	2.58	V
balanced starting voltage	3.500	3.525	3.550	V
Over current protection current	10		20	A
Over charge protection delay time	840	1200	1560	ms
Over discharge protection delay time	840	1200	1560	ms
Short protection delay time	210	300	390	us
Current consumption (Operation)				uA
Current consumption (Power down)	/	/	/	uA
Impedance			120	mΩ
Input voltage (B+ to B-)	/	/	/	V
Operating temperature	-20		+85	°C
Re commendatory storage condition	Temperature range: -5~+35°C Humidity: 0%~75%RH			
0V battery charge function	prohibit			

**6 6 Reliability test**

6.6.1 Humidity test:  $+40\pm 2^{\circ}\text{C}$ , 90%RH, 48h.

6.6.2 High temp. test:  $+85\pm 2^{\circ}\text{C}$ , 2h.

6.6.3 Low temp. test:  $-20\pm 2^{\circ}\text{C}$ , 16h

6.6.4 ESD test: All parts work normally at  $\pm 4\text{KV}$  (contact)  $\pm 8\text{KV}$  (air).

**6 7 Parts list:**

Item	Part Name	Description	QTY	Footprint	Supplier	Remark
1	IC	CM13C1	1	SSOP28		
2	MOS		2	TO-252	/	

## **7. Storage and Transportation**

### **7.1 Storage:**

7.1.1 The Li-ion battery pack should be stored in a cool, dry and well-ventilated area and should be kept far away from the fire and high temperature.

7.1.2 The best capacity for storage is 30%-50%

7.1.3 The battery should be stored in the temperature range as stated in this specification sheet. The best storage temperature is 0 to 25°C. The best humidity is 60±25%.

7.1.4 If store the battery six months or longer, suggest carry on additional charge to the battery.

### **7.2 Transportation:**

7.2.1 Do not mix the battery products with other cargoes.

7.2.2 Do not immerse the battery products in water or get it wet.

7.2.3 Do not do over 7 layer- staking and upside-down.

7.2.4 The highest temperature in transportation is lower than 65°C.

## **8. Battery Precautions and Safety Instructions:**

To ensure proper use of the battery please read the instructions carefully before using it.

### **8.1 Handling:**

8.1.1 Do not expose or dispose the battery in fire.

8.1.2 Do not put the battery in a charger or equipment with wrong terminals connected.

8.1.3 Avoid battery short circuit.

8.1.4 Avoid excessive physical shock or vibration.

8.1.5 Do not disassemble or deform the battery.

8.1.6 Do not immerse in water.

8.1.7 Do not use the battery mixed with other brand, type or model.

8.1.8 Keep out of the reach of children.

## **8.2 Charge:**

8.2.1 Battery must be charged in appropriate charger only.

8.2.2 Never use a modified or damaged charger.

8.2.3 Do not leave battery in charger over 24 hours.

8.2.4 Charging current: Don't surpass the highest charge current as stated in this specification sheet.

8.2.5 Charging voltage: Don't surpass the highest charge voltage as stated in this specification sheet.

8.2.6 Charge temperature: The battery must be charged in the ambient temperature range as stated in this specification sheet.

8.2.7 Charge the battery via constant current first and then via constant voltage, no reverse charge. If the positive electrode and the cathode mixed, the battery can be damaged.

8.2.8 Store the battery after it's charged. The battery should be recharged/re-discharged every 3 months.

## **8.3 Discharge:**

8.3.1 The discharge current shouldn't surpass the highest discharge current as stated in this specification sheet. If surpass, the battery may be damaged and it can result in hot battery which is risk.

8.3.2 Discharge temperature range: The discharge must be done in the ambient temperature range as stated in this specification sheet

8.3.3 Over-discharge: A short-time over-discharge will not affect the use of the battery, but long-time will do. If the battery is not used for a long time, the performance will get poorer. It should be recharged and re-discharged fully several times before it's recovered.

## **8.4 Disposal:**

Regulation is vary in different countries. Please dispose wasted battery according to local regulations.

## 9. Period of Warranty

There is a twelve-month warranty of the batteries from the date of shipment. If there is quality problem within, we are responsible to replace the defective ones according to the accurate analysis results. However, we won't take any responsibility if the problem is caused by the battery-related applications and related products.

## 10. Package

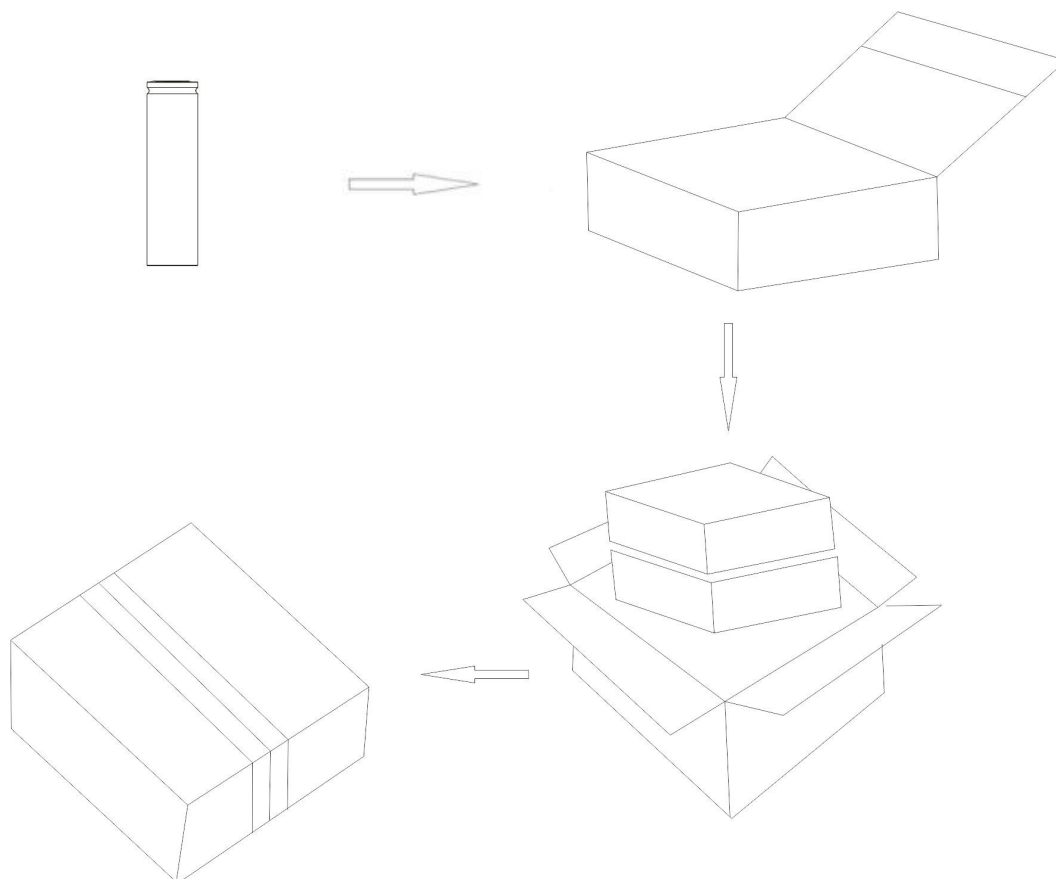

## 11. Others

Battery is chemical product, the performance will be deteriorated when it's used for a long time or it's stored for a long time without being used. In addition, if it's not charged or discharged properly as stated in this specification sheet, the capacity and lifespan will be shortened, or the product which the battery applied to will be damaged by its leaking. If the battery is charged properly but can't be charged fully, please replace it in time.

## 12. Special Request

If your need isn't fulfilled by this specification, we can custom design per your request. Just write down your request, we're more than happy to serve you. Thank you.

	Special Request	Criteria
1		
2		
3		
4		
5		
6		