

Lithium-Ion Rechargeable Battery

Primary characteristics	
Parameter	Value
Nominal voltage	3.6V
Rated capacity	5000mAh

Scope

The purpose of this product specification is to provide technical information for the rechargeable Lithium-ion cylindrical battery INR21700-50M-35A.

The test shall be conducted in strict accordance with the method specified in this specification.

If you have any objection to the test items or test methods, please contact Akyga Battery.

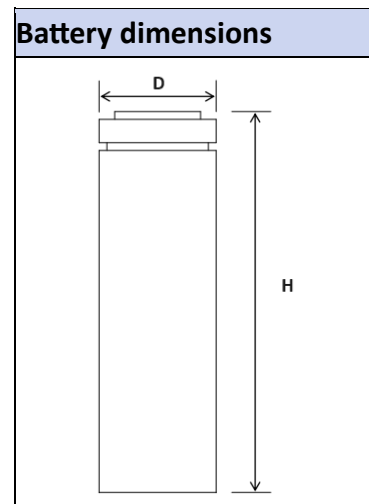

Specification table		
Parameter	Value	
Model	INR21700-50M-35A	
Typical voltage	3.6V	
Rated capacity ¹⁾	5000mAh	
Minimum capacity	4900mAh	
Standard charge current	CCCV 1.0A (0.2C), 4.2±0.02V, 0.2A cut-off	
Max. charge current	CCCV 10.0A (2C), 4.2±0.02V, 0.2A cut-off	
Standard discharge current	1.0A (0.2C), 2.50V cut-off	
Max. discharge current	20A (without temperature cut)	Max. instantaneous discharge current 90A (2s), T≥0° C
	35A (with 75° C temperature cut)	
Charge/Discharge voltage range	4.20V~2.50V	
Operation temperature	Charge	0~45°C
	Discharge	-20~60°C
Storage temperature	< 1 year	-20~25°C
	< 3 months	-10~45°C
Cycle life	After 500th cycles, ≥80%	
Internal resistance	≤15mΩ	
Size	Diameter	21.15 ± 0.10 mm
	Height	70.15 ± 0.15 mm
Weight (approx.)	72.0g	
Notes:		
¹⁾ Rated capacity test conditions: Charge: 1A(0.2C), 4.20V, CCCV 0.1A cut-off Discharge: 1A(0.2C), 2.50V cut-off		
²⁾ Cycle life: Charge: 2.5A(0.5C), 4.20V, 0.1A cut-off. Discharge: 5.0A(1C) discharge, 2.50V, 20±5°C Rest Time: 30min after charge and 30min after discharge		

Caution

- The battery used in this device may present a risk of fire or chemical burn if mistreated.
- Do not expose the cell to extreme heat or flame.
- Do not short circuit, over-charge or over-discharge the cell.
- Do not subject the cell to strong mechanical shocks.
- Do not immerse the cell in water or sea water, or get it wet.
- Do not reverse the polarity of the cell for any reason.
- Do not disassemble or modify the cell.
- Do not handle or store with metallic like necklaces, coins or hairpins, etc.
- Do not use the cell with conspicuous damage or deformation.
- Do not connect cell to the plug socket or car-cigarette-plug.
- Do not make the direct soldering onto a cell.
- Do not touch a leaked cell directly.
- Do not use or leave the cell under the blazing sun.
- Keep cell away from children.
- Do not drive a nail into the cell, strike it by hammer or tread it.
- Replace battery with those of Akyga Battery only.

Ropla Elektronik HP sp. z o o.
ul. Wrocławska 1C,52-200 Suchy Dwór, Polska
Contact: sales@akygabattery.com

**Disclaimer**

Akyga battery reserves the right to make changes without notice to any product specification herein, to make corrections, modifications, enhancements or other changes. Akyga battery or anyone on its behalf assumes no responsibility or liability for any errors or inaccuracies. Data sheet specifications and its information contained are intended to provide a product description only. "Typical" parameters which may be included on Akyga battery data sheets and/ or specifications can and do vary in different applications and actual performance may vary over time. Akyga battery does not assume any liability arising out of the application or use of any product or circuit. Akyga battery products are not designed, intended or authorized for use in medical, life-saving implant or other applications intended for life-sustaining or other related applications where a failure or malfunction of component or circuitry may directly or indirectly cause injury or threaten a life without expressed written approval of Akyga battery. Customers using or selling Akyga battery components for use in such applications do so at their own risk and shall agree to fully indemnify Akyga battery and its subsidiaries harmless against all claims, damages and expenditures.