

Primary Lithium Battery Li-MnO₂

Primary characteristics		
Parameter	Value	Unit
Nominal voltage	3.0	V
Rated capacity	800	mAh

Scope

The purpose of this product specification is to provide technical information for the lithium Li-MnO₂ battery CR14335.

The test shall be conducted in strict accordance with the method specified in this specification.

If you have any objection to the test items or test methods, please contact Akyga battery.

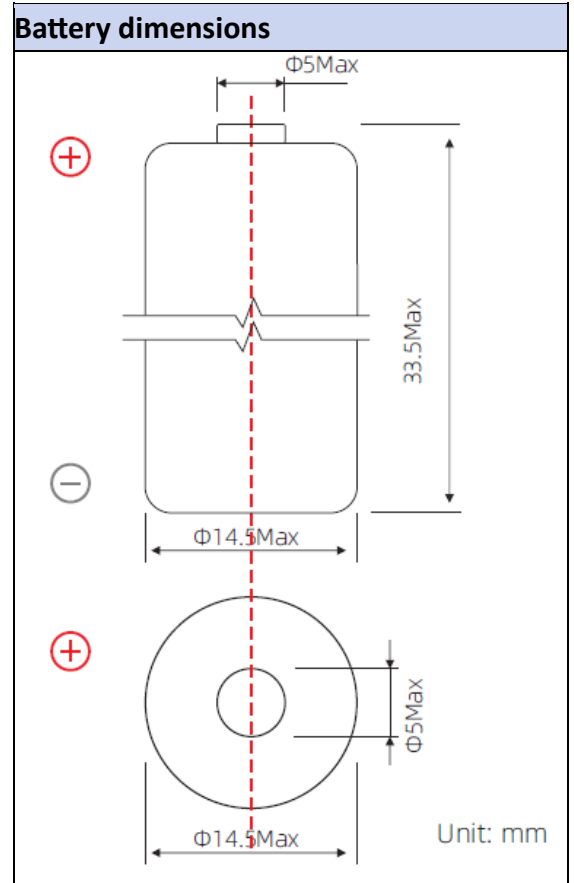

Specification table		
Parameter	Value	Unit
Battery model*	CR14335	
Nominal voltage	3.0	V
Nominal capacity	800	mAh
Max constant current	500	mA
Max pulse current	1200	mA
Operating temperature	-40/+85	°C
<p>Notes: Nominal capacity test conditions: 5mA resistive load, end voltage: 2.0V, operating temperature 25°C±1°C *Pins and other leads can be added to the battery</p>		

Warning

- Don't place the battery in heater, washer or high-pressure container.
- Don't use the battery together with different kind of battery.
- Stop using when the battery become heat, emit or appear other abnormality during use or storing.
- Don't recharge the battery.
- Don't force-discharge the battery.
- Keep away from the battery when the battery is leakage or emit abnormal smell
- Was yourself quickly when the electrolyte infiltrate to your skin or clothes
- Wash your eyes by clean water quickly and go to hospital for further check if the electrolyte infiltrate to your eyes
- If two or more batteries are to be connected in a series and/or placed in a parallel arrangement, protective circuit must be connected with batteries, so that to avoid force-discharging or recharging.

Storage

- The batteries should be stored at 10°C to 25°C (never exceed 30°C), 45% to 75% RH.
- The batteries should not be stored next to heat sources or in direct sunlight. The storage area should be clean, cool, dry, ventilated and weatherproof.
- The height to which batteries may be stacked is clearly dependent on the strength of the packing. As a general rule, this height should not exceed 1.5m for cardboard packages nor 3m for wooden cases.
- Store and display batteries in their original package. The batteries may be short-circuited or damaged if been unpacked and stacked messily.
- Long Shelf Life (less than 1% per year after 1 year of storage at 25°C)

Declaration

Akyga Battery reserves the right to make changes without notice to any product specification herein, to make corrections, modifications, enhancements or other changes. Akyga Battery or anyone on its behalf assumes no responsibility or liability for any errors or inaccuracies. Data sheet specifications and its information contained are intended to provide a product description only. "Typical" parameters which may be included on Akyga Battery data sheets and/ or specifications can and do vary in different applications and actual performance may vary over time. Akyga Battery does not assume any liability arising out of the application or use of any product or circuit. Akyga Battery products are not designed, intended or authorized for use in medical, life-saving implant or other applications intended for life-sustaining or other related applications where a failure or malfunction of component or circuitry may directly or indirectly cause injury or threaten a life without expressed written approval of Akyga Battery. Customers using or selling Akyga Battery components for use in such applications do so at their own risk and shall agree to fully indemnify Akyga Battery and its subsidiaries harmless against all claims, damages and expenditures.