

PRODUCT NUMBER

75867-YXX

PIN STYLE
SEE SHEET 2
PLATING SEE SHEET 2

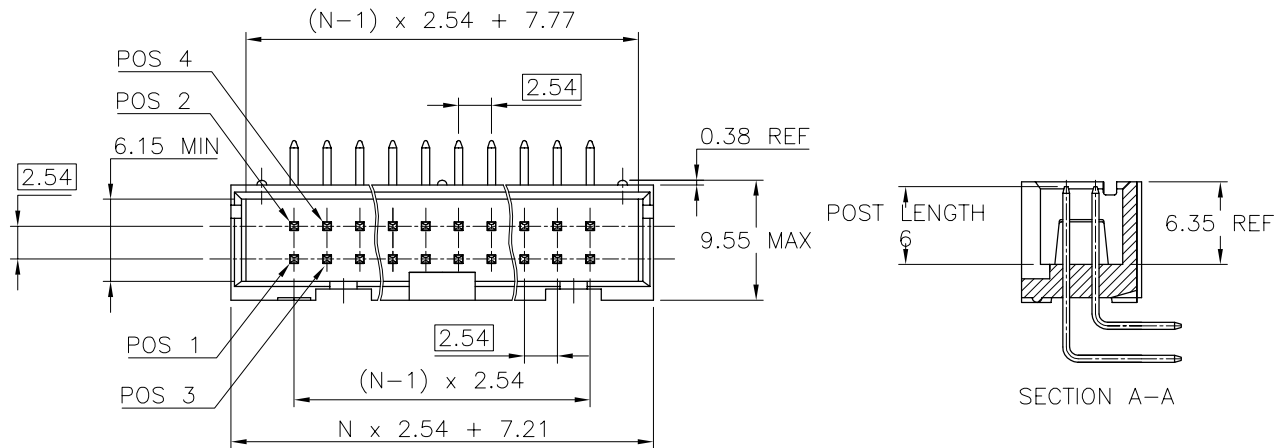

NOTES:

- 1 - HOUSING MAT'L : GLASS FILLED THERMOPLASTIC. UL94V-0 COLOR: BLUE
- 2 - PIN MATERIAL : PHOSPHOR BRONZE
- 3 - PRODUCT PACKAGED IN TUBES.
- 4 - TO DETERMINE DIMENSIONS :
N = NUMBER OF POSITIONS PER ROW
EXAMPLE : 8 POS N x 2.54 = 20.32mm

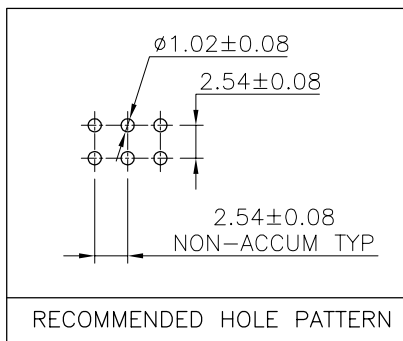
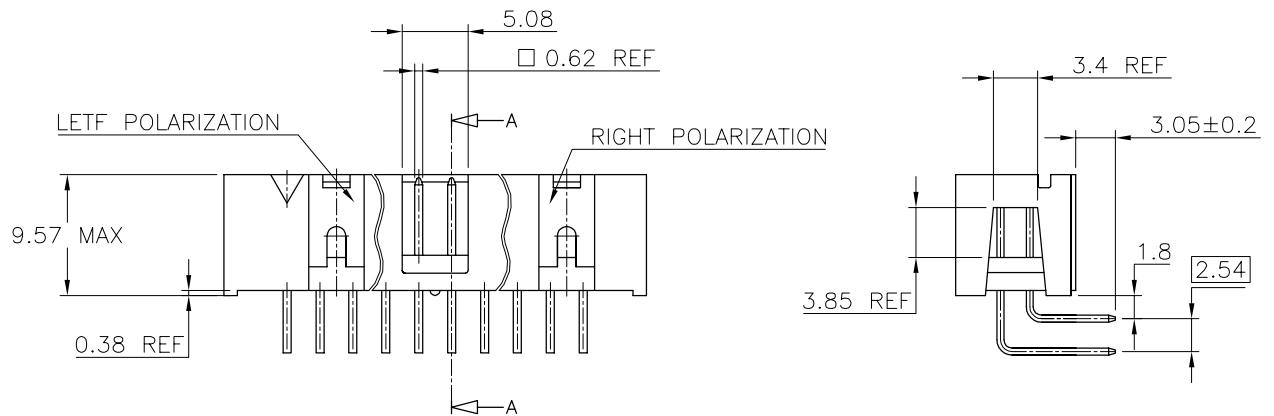

mat'l. code		tolerances unless otherwise specified		CUSTOMER COPY		ELECTRONICS www.fciconnect.com	
SEE NOTES				projection		title	
ltr	ecn no	dr	date	linear	 mm scale 2.5:1	SHR.LP.HEADER RA DR TMT	
AB	F00492	LMU	00.09.04	.x ±0.3		product family QUICKIE	
AC	F10120	DLE	01.01.24	.xx ±0.15		code 213	
AD	F04-0147	LMU	04.02.26	angles	size A3 dwg no 75867	sheet 1 of 2	
AE	F04-0167	JCO	04.04.05	dr		sheet 1 of 2	
				D.LE		sheet 1 of 2	
				enr	JM.C	sheet 1 of 2	
				chr	JF.N	sheet 1 of 2	
				appd	JM.C	sheet 1 of 2	
sheet index	revision sheet	AE	AD				
	1	2					

CORE RANGE

PIN STYLE	Nbr OF POSITIONS	LEFT POLARIZATION	RIGHT POLARIZATION
30	2 x 2	NO	NO
31	2 x 3	NO	NO
32	2 x 4	NO	NO
01	2 x 5	NO	YES
02	2 x 7	NO	YES
03	2 x 8	YES	YES
04	2 x 10	YES	YES
05	2 x 13	YES	YES
33	2 x 15	YES	YES
06	2 x 17	YES	YES
07	2 x 20	YES	YES
08	2 x 25	YES	YES
09	2 x 30	YES	YES
10	2 x 32	YES	YES

CATALOGUE RANGE

PIN STYLE	Nbr OF POSITIONS	LEFT POLARIZATION	RIGHT POLARIZATION
30	2 x 2	NO	NO
31	2 x 3	NO	NO
32	2 x 4	NO	NO
01	2 x 5	NO	YES
02	2 x 7	NO	YES
03	2 x 8	YES	YES
04	2 x 10	YES	YES
05	2 x 13	YES	YES
33	2 x 15	YES	YES
06	2 x 17	YES	YES
07	2 x 20	YES	YES
08	2 x 25	YES	YES
09	2 x 30	YES	YES
10	2 x 32	YES	YES

APLLICATION SPECIFIC

PIN STYLE	Nbr OF POSITIONS	LEFT POLARIZATION	RIGHT POLARIZATION	OMIT PIN
13	2 x 17	YES	YES	5
14	2 x 20	YES	YES	19
34	2 x 5	NO	YES	5
35	2 x 10	YES	YES	19
36	2 x 20	YES	YES	10
37	2 x 20	YES	YES	11
38	2 x 20	YES	YES	20

PLATING

- 1= 0.76µm GOLD ON CONTACT AREA
TIN/LEAD ON TAIL
- 2= 3.81µm TIN/LEAD ALL
- 3= 0.38µm GOLD ON CONTACT AREA
TIN/LEAD ON TAIL

PLATING

- 1= 0.76µm GOLD ON CONTACT AREA
TIN/LEAD ON TAIL

PLATING

- 2= 3.81µm TIN/LEAD ALL
- 3= 0.38µm GOLD ON CONTACT AREA
TIN/LEAD ON TAIL

Tous droits strictement reserves. Reproduction ou communication
 sous quelque forme que ce soit sans autorisation écrite de
 l'entreprise FCI Electronics S. A.
 Copyright © FCI Electronics S. A.

All rights strictly reserved. Reproduction or issue to third parties
 in any form is not permitted without written authority from the
 property of FCI Electronics S. A.
 Copyright © FCI Electronics S. A.



ELECTRONICS
www.fciconnect.com

mat'l. code		tolerances unless otherwise specified		CUSTOMER COPY			
ltr	ecn no	dr	date	linear	projection	title	
AB	F00492	LMU	00.09.04			SHR.LP.HEADER	
AC	F10120	DLE	01.01.24			RA DR TMT	
AD	F04-0147	LMU	04.02.26	angles			
				dr	D.LE	01.01.24	product family QUICKIE
				engr	JM.C	01.01.24	code
				chr	JF.N	01.01.24	size
				appd	JM.C	01.01.24	dwg no
sheet index	revision sheet				scale		
					N/A		
						A3	75867
							213
							sheet
							2 of -