

1 | 2

3

4

PRODUCT NUMBER  
SEE TABLE

Tous droits strictement reserves. Reproduction ou communication a des tiers interdite sous quelque forme que ce soit sans autorisation ecrite du proprietaire. Propriete de c FCI. Droits de reproduction FCI.

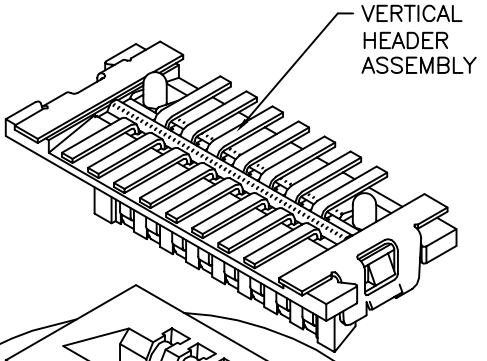

VERTICAL  
HEADER  
ASSEMBLY

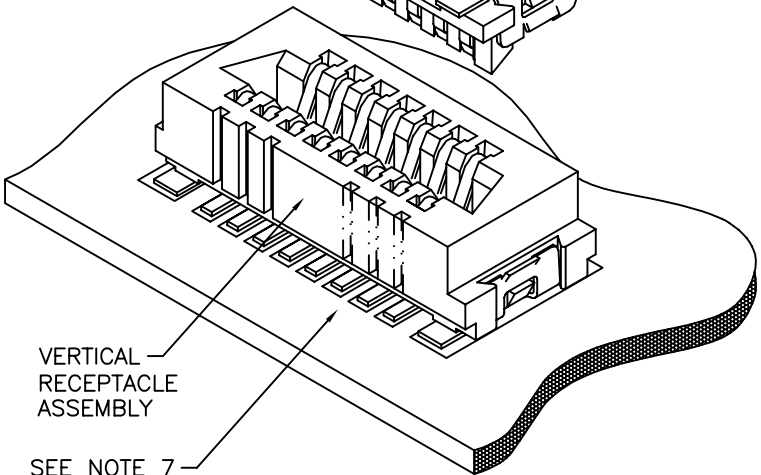

VERTICAL  
RECEPTACLE  
ASSEMBLY

SEE NOTE 7

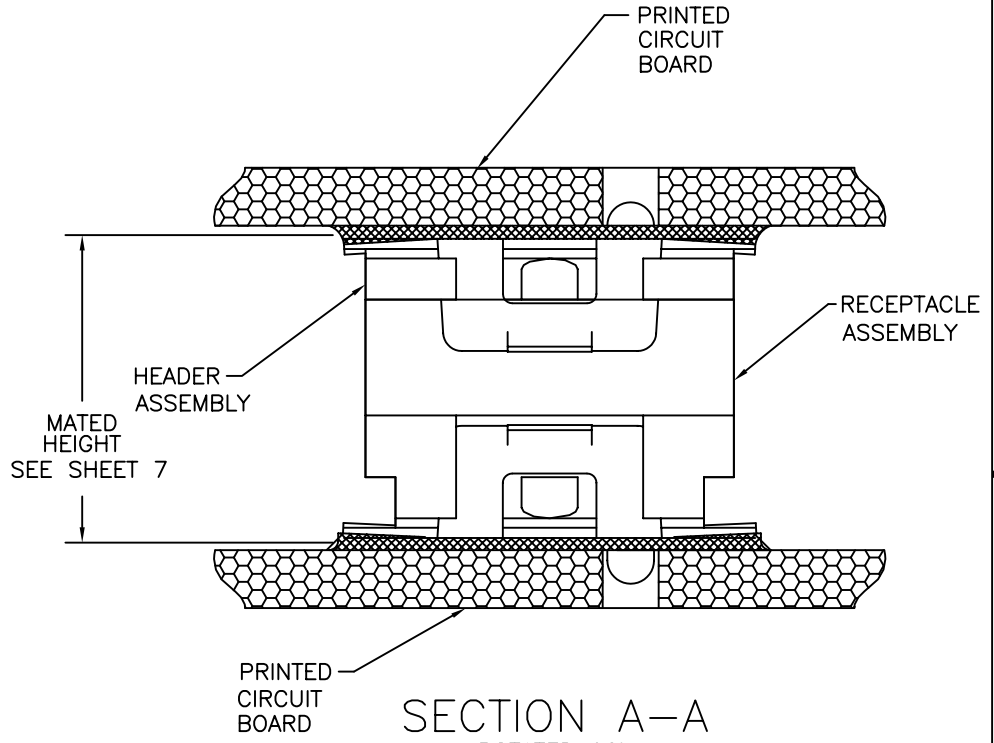

SECTION A-A  
ROTATED 90°  
N.T.S.

FCI

All rights strictly reserved. Reproduction or issue to third parties in any form whatever is not permitted without written authority from the proprietor. Property of FCI. Copyright FCI.

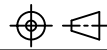
mat'l. code				tolerances unless otherwise specified				CUSTOMER COPY		 www.fciconnect.com	
ltr	ecn no	dr	date	linear	.XX ±.01/.X±.3			projection	title		
T	V61746	EPK	11/25/96		.XXX ±.005/.XX±.13				CONAN™ CONNECTOR ASSEMBLY		
U	V70158	EPK	05/05/96		.XXX ±.0020/.XXX±.051				product family CONAN code 213		
V	V91454	EPK	07/01/96	angles	0° ±2'			 INCH/MM	size		sheet
W	V11093	CRG	03/21/01	dr	R.SEIPLE	11/13/91	A		91900		1 of 7
X	V12858	CRG	12/20/01	engr	D.HORCHLER	01/10/92	scale				
Y	V03-1347	PJ	01/23/04	chr	D.HORCHLER	01/10/92	5:1				
AA	M04-0190	MHT	9/24/04	appd	D.HORCHLER	01/10/92					
sheet index	revision sheet	AA	Y	Y	Y	Y	AA	AA			
		1	2	3	4	5	6	7			

1 | 2

3

4

ACAD

PDM: Rev:AA

STATUS: Released

cage code  
22526

Printed: Oct 28, 2004

Tous droits strictement réservés. Reproduction ou communication a des tiers interdite sous quelque forme que ce soit sans autorisation écrite du propriétaire. Propriété de c FCI. Droits de reproduction FCI.

All rights strictly reserved. Reproduction or issue to third parties in any form whatever is not permitted without written authority from the proprietor. Property of FCI. Copyright FCI.

PRODUCT NUMBER  
SEE TABLE

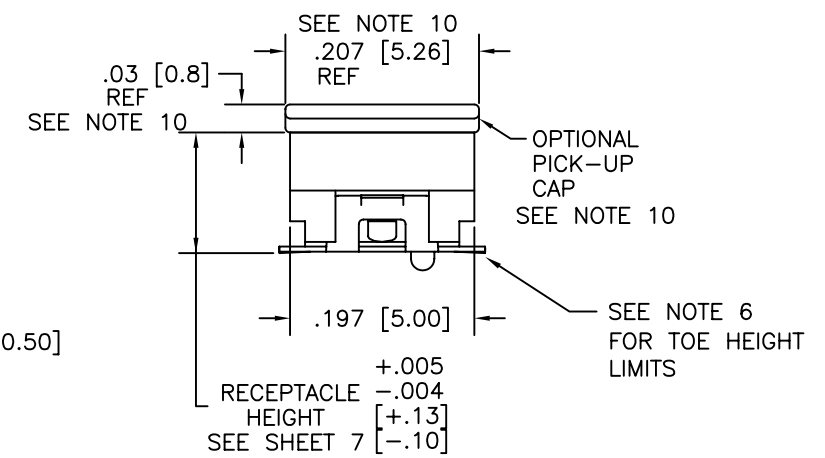
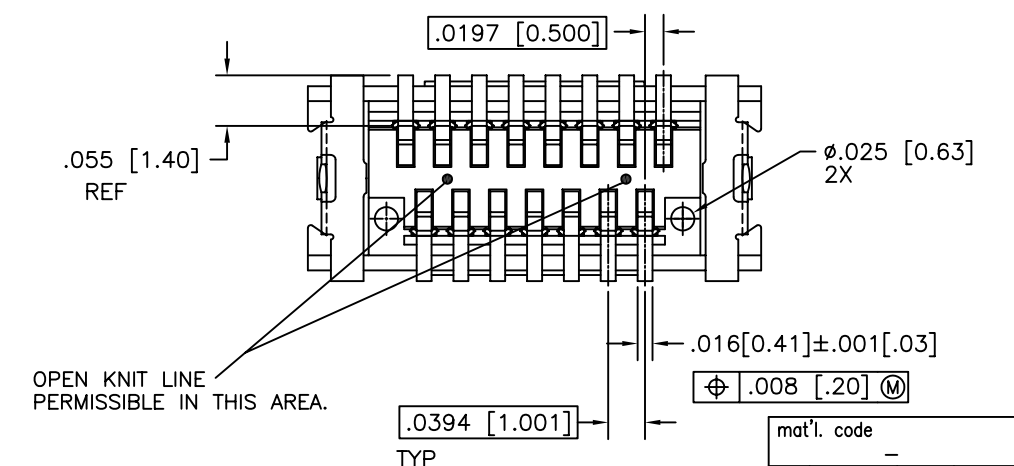
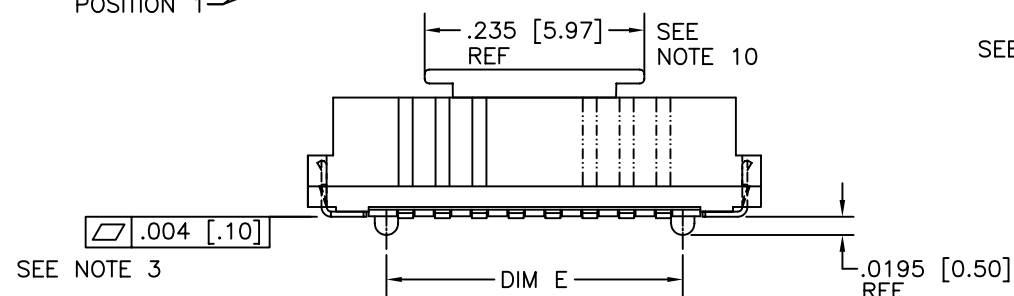
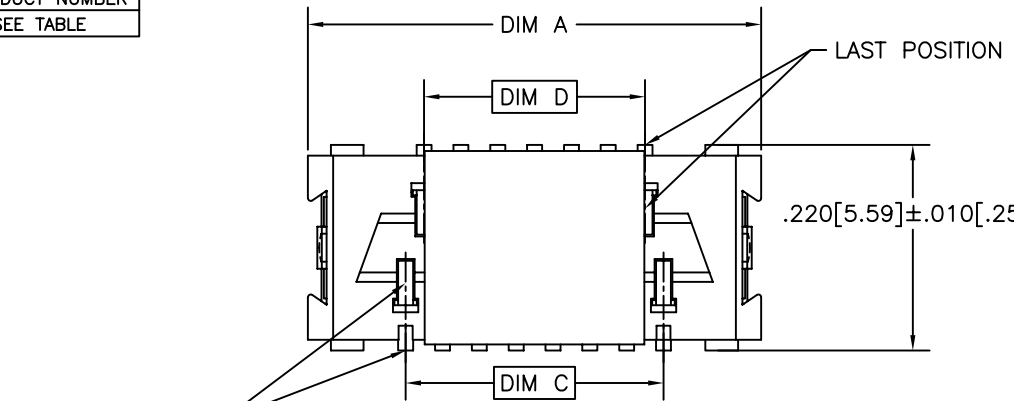

mat'l. code				tolerances unless otherwise specified		CUSTOMER COPY		 www.fciconnect.com		
ltr	ecn no	dr	date	linear	.XX ±.01/.X±.3	projection	title			
Y					.XXX ±.005/.XX±.13			CONANT™ CONNECTOR ASSEMBLY		
					.XXX ±.0020/.XXX±.051			product family CONAN		code 213
				angles	0° ±2°		size		sheet 2 of 7	
				dr	R.SEIPLE 11/13/91		A 91900			
				enr	D.HORCHLER 01/10/92	scale 5:1				
				chr	D.HORCHLER 01/10/92					
				appd	D.HORCHLER 01/10/92					
sheet index	revision sheet							cage code 22526		

Tous droits strictement reserves. Reproduction ou communication a des tiers interdite sous quelque forme que ce soit sans autorisation ecrite du proprietaire. Propriete de c FCI. Droits de reproduction FCI.

All rights strictly reserved. Reproduction or issue to third parties in any form whatever is not permitted without written authority from the proprietor. Property of FCI. Copyright FCI.

PRODUCT NUMBER  
SEE TABLE

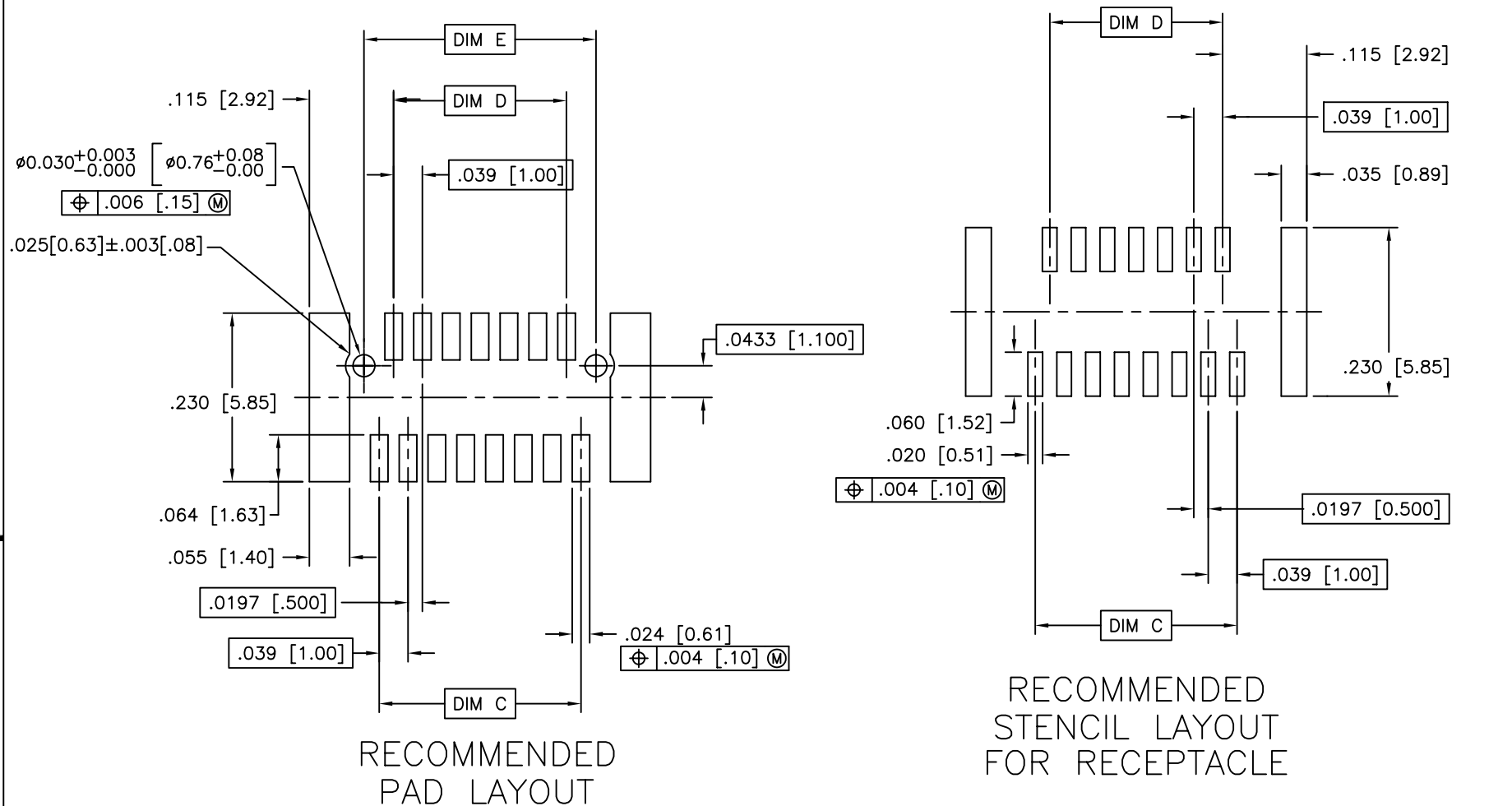

RECOMMENDED PAD LAYOUT

RECOMMENDED STENCIL LAYOUT FOR RECEPTACLE

mat'l. code				tolerances unless otherwise specified				CUSTOMER COPY		 www.fciconnect.com	
ltr	ecn no	dr	date	linear	.XX ±.01/.X±.3			projection	title		
Y					.XXX ±.005/.XX±.13				CONANT™ CONNECTOR ASSEMBLY		
					.XXX ±.0020/.XXX±.051				product family CONAN code 213		
				angles	0° ±2°			INCH/MM	size dwg no		
				dr	M.CORNMAN	04/29/94	scale		A 91900 sheet 3 of 7		
				enr	D.WHITING	04/29/94		5:1			
				chr	D.WHITING	04/29/94					
				appd	D.WHITING	04/29/94					
sheet index	revision sheet										

Tous droits strictement reserves. Reproduction ou communication a des tiers interdite sous quelque forme que ce soit sans autorisation ecrite du proprietaire. Propriete de c FCI. Droits de reproduction FCI.

All rights strictly reserved. Reproduction or issue to third parties in any form whatever is not permitted without written authority from the proprietor. Property of FCI. Copyright FCI.



PRODUCT NUMBER  
SEE TABLE

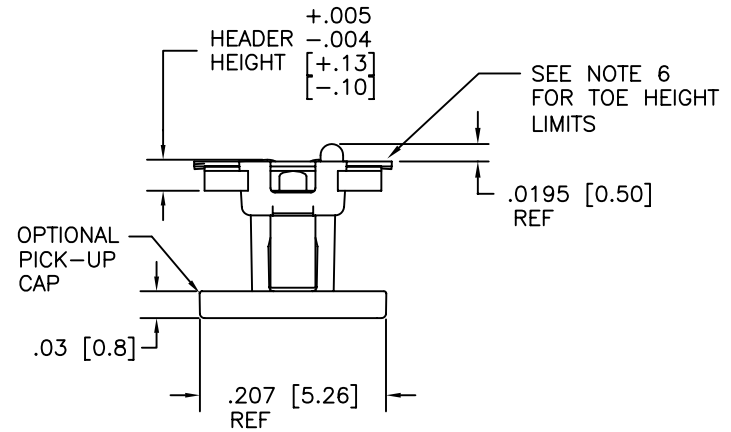
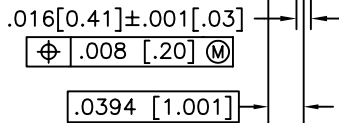
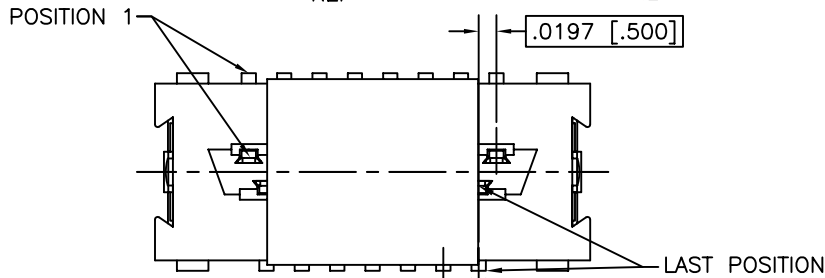
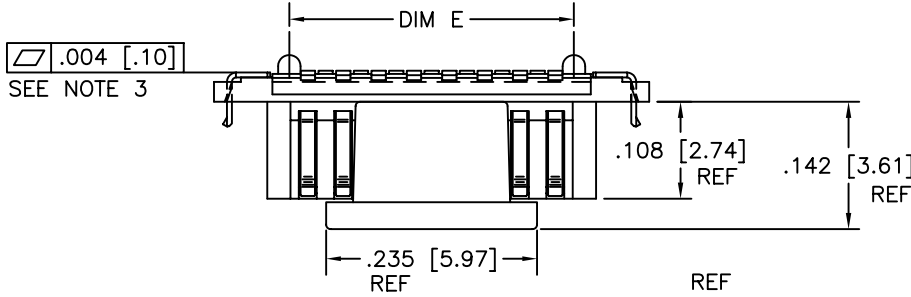
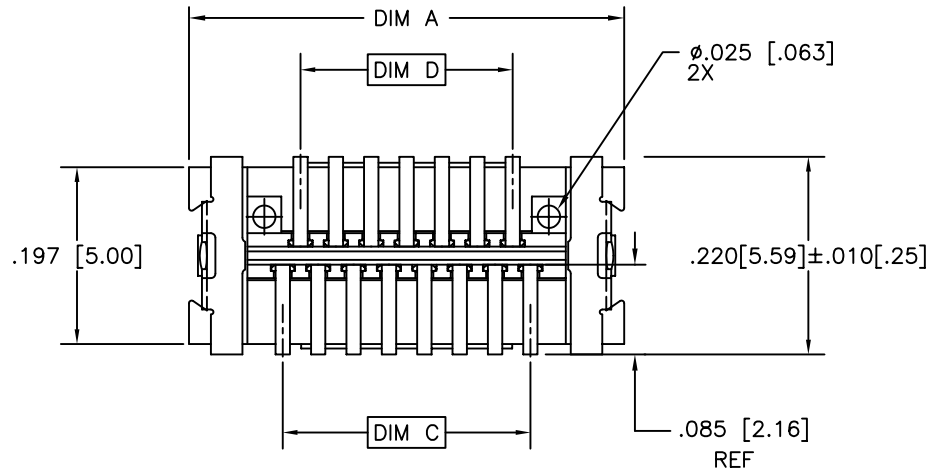

mat'l. code				tolerances unless otherwise specified			CUSTOMER COPY		 www.fciconnect.com	
ltr	ecn no	dr	date	linear	.xx ±.01/.x±.3		projection	title		
Y					.xxx ±.005/.xx±.13			CONANT™ CONNECTOR ASSEMBLY		
				angles	0° ±2'		 INCH/MM	product family		code
				dr	R.SEIPLE	11/13/91		CONAN		213
				enr	D.HORCHLER	01/10/92	scale	size  dwg no		sheet
				chr	D.HORCHLER	01/10/92		A 91900		4 of 7
				appd	D.HORCHLER	01/10/92				
sheet index	revision sheet									

PRODUCT NUMBER  
SEE TABLE

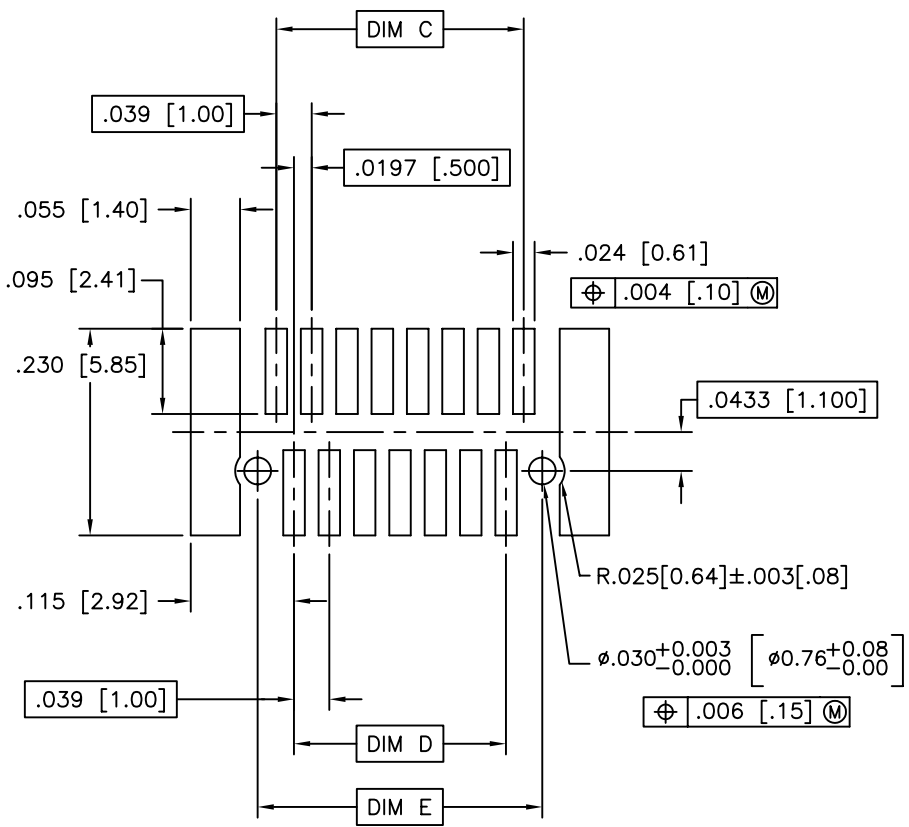

RECOMMENDED  
PAD LAYOUT

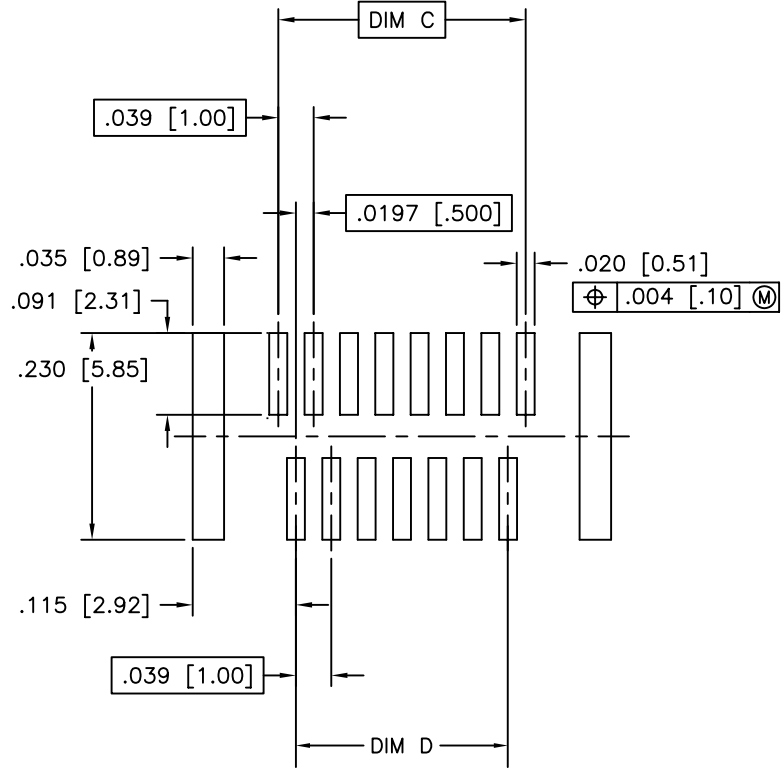

RECOMMENDED  
STENCIL LAYOUT  
FOR HEADER

Tous droits strictement reserves. Reproduction ou communication a des tiers interdite sous quelque forme que ce soit sans autorisation ecrite du propriétaire. Propriete de c FCI. Droits de reproduction FCI.



All rights strictly reserved. Reproduction or issue to third parties in any form whatever is not permitted without written authority from the proprietor. Property of FCI. Copyright FCI.

A

A

B

B

mat'l. code				tolerances unless otherwise specified		CUSTOMER COPY		 www.fciconnect.com		
ltr	ecn no	dr	date	linear	.xx ±.01/.x±.3	projection	title			
Y					.xxx ±.005/.xx±.13		 INCH/MM	CONANT™ CONNECTOR ASSEMBLY		
					.xxx ±.0020/.xxx±.051			product family	CONAN	code
				angles	0° ±2'	scale	size	dwg no	sheet	
				dr	M.CORNMAN 04/29/94	5:1	A	91900	5 of 7	
				enr	D.WHITING 04/29/94					
				chr	D.WHITING 04/29/94					
				appd	D.WHITING 04/29/94					
sheet index	revision sheet									

Tous droits strictement reserves. Reproduction ou communication a des tiers interdite sous quelque forme que ce soit sans autorisation écrite du propriétaire. Propriete de c FCI. Droits de reproduction FCI.

PRODUCT NUMBER	POS	DIM "A"	DIM "C"	DIM "D"	DIM "E"
919TC-WXY09	9	.366 [9.30]	.157 [4.00]	.118 [3.00]	.1990 [5.055]
↑ -WXY09LF					
-WXY11	11	.406 [10.30]	.197 [5.00]	.157 [4.00]	.2380 [6.045]
-WXY11LF					
-WXY15	15	.484 [12.30]	.276 [7.00]	.236 [6.00]	.3170 [8.052]
-WXY15LF					
-WXY21	21	.602 [15.30]	.394 [10.00]	.354 [9.00]	.4350 [11.049]
-WXY21LF					
-WXY25	25	.681 [17.30]	.472 [12.00]	.433 [11.00]	.5140 [13.056]
-WXY25LF					
-WXY31	31	.800 [20.30]	.591 [15.00]	.551 [14.00]	.6320 [16.053]
-WXY31LF					
-WXY41	41	.996 [25.30]	.787 [20.00]	.748 [19.00]	.8290 [21.057]
-WXY41LF					
-WXY51	51	1.193 [30.30]	.984 [25.00]	.945 [24.00]	1.0260 [26.060]
-WXY51LF					
-WXY69	69	1.547 [39.30]	1.339 [34.00]	1.299 [33.00]	1.3800 [35.052]
↓ -WXY69LF					

NOTES:

- MATERIALS:  
RECEPTACLE HOUSING - LCP, COLOR; NATURAL.  
RECEPTACLE TERMINALS - COPPER ALLOY,  
TIN LEAD PLATING: PLATED WITH 15u"/.38u GXT IN CONTACT AREA AND 100u"/2.54u SnPb ON SOLDER LEGS WITH AN OVERALL 50u"/1.27u Ni UNDERPLATE.  
LEAD FREE PLATING: 100u"/2.54u PURE TIN PLATING ON SOLDER LEGS AN OVERALL 50u"/1.27u Ni UNDERPLATE.  
HEADER HOUSING - LCP, COLOR: NATURAL.  
HEADER TERMINALS - COPPER ALLOY,  
TIN LEAD PLATING: PLATED WITH 15u"/.38u GXT IN CONTACT AREA AND 100u"/2.54u SnPb ON SOLDER LEGS WITH AN OVERALL 50u"/1.27u Ni UNDERPLATE.  
LEAD FREE PLATING: 100u"/2.54u PURE TIN PLATING ON SOLDER LEGS AN OVERALL 50u"/1.27u Ni UNDERPLATE.  
RETENTION DEVICE - BRASS,  
TIN LEAD PLATING: PLATED WITH 100u"/2.54u SnPb OVER NICKEL.  
LEAD FREE PLATING: PLATED WITH 100u"/2.54u Sn OVER NICKEL.
- REFERENCE GS-12-006 FOR PRODUCT PERFORMANCE DATA.
- SEE TA-774 FOR FURTHER DESCRIPTION OF HOW THIS DIMENSION IS APPLIED.
- PICK AND PLACE CAP OR TAPE IS ONLY AVAILABLE WITH OPTION 3 PACKAGING. (PSA ADHESIVE SEALED). ALSO, PSA PACKAGING REQUIRES A PICK AND PLACE CAP.
- RECOMMENDED SOLDER PASTE THICKNESS IS .006 TO .008 INCHES THICK.
- THE TOE HEIGHT OF THE SOLDER TAIL SHALL BE MEASURED FROM THE LOWEST POINT OF THE .004 CO-PLANARITY GRAVITY PLANE. THIS MEASUREMENT IS NOT TO EXCEED A WINDOW OF .000 TO .007 INCHES.
- THREE SLOTS MAY BE LOCATED AT EITHER END OF HOUSING.
- 5.50mm MATED HEIGHT IS ONLY AVAILABLE IN 9, 15 AND 31 POS.
- 7.50mm MATED HEIGHT IS ONLY AVAILABLE IN 9 POS.
- APPLIES TO 91921-3XYZZ AND 91931- 3XYZZ OPTIONS ONLY.
- PART NUMBER WITH LEAD FREE IN TIN LEAD END ARE LEAD FREE OPTION. SEE CONAN ASSY P/N NUMBERS
- THE HOUSING WILL WITHSTAND EXPOSURE TO 260° PEAK TEMPERATURE FOR 30 SECONDS IN A CONVENTION INFRA RED OR VAPOR PHASE REFLOW OVEN.

STATEMENT: "THIS PRODUCT MEETS THE REQUIREMENTS OF THE EUROPE UNION DIRECTIVE OF RESTRICTIONS FOR HAZARDOUS SUBSTANCES (DIRECTIVE 2002/95/EC) AND CAN BE PROCESSED IN THE PROCESS CONDITIONS FOR WHICH THE PRODUCT IS DEVELOPED. FCI, ITS SUBSIDIARIES AND AFFILIATES ("FCI") PROVIDES THE ABOVE DATA AND INFORMATION IN GOOD FAITH BASED UPON CURRENT KNOWLEDGE AND EXPERIENCE, BUT MAKE NO WARRANTY THAT SUCH DATA OR INFORMATION IS FREE FROM ERROR, IS COMPLETE OR IS SUFFICIENT FOR USER'S INTENDED PURPOSE EVEN IF MADE KNOWN TO FCI. FCI SPECIFICALLY DISCLAIMS ANY WARRANTY, EXPRESS OR IMPLIED, AND ASSUMES NO LIABILITY WITH RESPECT TO THE EFFECTIVENESS OR SAFETY OF THE PRODUCTS LISTED ABOVE. EACH USER MUST MAKE ITS OWN DETERMINATION AS TO THE SUITABILITY OF FCI'S PRODUCTS AND MATERIALS FOR ITS OWN PARTICULAR PURPOSE, AND MUST ASSURE THAT ITS PRODUCTS FABRICATE FROM FCI'S PRODUCTS AND MATERIALS ARE SAFE AND LAWFUL. IT IS THE USER'S RESPONSIBILITY TO ASSURE PROPER USE ABS DISPOSAL OF FCI'S PRODUCTS AND MATERIALS, THE SAFETY AND HEALTH OF USER'S EMPLOYEES AND CUSTOMER, AND USER'S COMPLIANCE WITH APPLICABLE LAWS AND REGULATIONS.."



All rights strictly reserved. Reproduction or issue to third parties in any form whatever is not permitted without written authority from the proprietor. Property of FCI. Copyright FCI.

A

A

B

B

mat'l. code		tolerances unless otherwise specified		CUSTOMER COPY	 www.fciconnect.com
ltr	ecn no	dr	date	linear	
AA				.xx ±.01/.X±.3	projection
				.xxx ±.005/.xx±.13	
				.xxx ±.0020/.xxx±.051	
				angles	0° ±2°
				dr	R.SEIPLE 01/13/91
				enr	D.HORCHLER 01/10/92
				chr	D.HORCHLER 01/10/92
				appd	D.HORCHLER 01/10/92
sheet index	revision sheet				

PRODUCT NUMBER  
SEE TABLE

### CONAN ASSEMBLY PART NUMBER

919 T C - W X Y ZZ LF

LEAD FREE  
OPTION

TYPE	T
HEADER WITH NO PEGS	0
HEADER WITH PEGS	1
RECEPTACLE WITH NO PEGS	2
RECEPTACLE WITH PEGS	3

PICK AND PLACE CAP OR TAPE (NOTE 4)	C
WITHOUT CAP OR TAPE	0
WITH CAP	1
WITH TAPE (RECEPTACLE ONLY)	2

PACKAGING	W
TUBE	2
PRESSURE SEALED TAPE & REEL	3

Y	HEADER HEIGHT	RECEPTACLE HEIGHT	MATED HEIGHT	+0.10 -0.008 [+0.25] [-0.20]
1	.034 [.86]	.129 [3.28]	.163 [4.15]	
2	.048 [1.23]	SEE Y=1 FOR ALL RECEPTACLES	.177 [4.50]	
3	.068 [1.73]		.197 [5.00]	
4	.107 [2.72]		.236 [6.00]	
5	.1465 [3.721]		.276 [7.00]	
* 6	.088 [2.23]		.216 [5.50]	
* * 7	.1665 [4.229]		.296 [7.52]	

ZZ	NUMBER OF POSITIONS
09	9
11	11
15	15
21	21
25	25
31	31
41	41
51	51
69	69

X	PLATING
1	15u"/.38u GXT
2	30u"/.76u GXT

\* NOTE 8  
\* \* NOTE 9

NOTE 4

EXAMPLE: 91921-31125LF  
IS A CONAN RECEPTACLE ASSEMBLY,  
HAVING NO PEGS AND WITH A PICK AND PLACE CAP.  
IT ALSO HAS GXT PLATING, IS .13 [3.2] HIGH AND 25  
POSITIONS AND IS PACKAGED IN PRESSURE SEALED TAPE,  
REEL AND LEAD FREE.

Tous droits strictement reserves. Reproduction ou communication a des tiers  
interdite sous quelque forme que ce soit sans autorisation ecrite du proprietaire.  
Propriete de c FCI. Droits de reproduction FCI.



All rights strictly reserved. Reproduction or issue to third parties in any  
form whatever is not permitted without written authority from the proprietor.  
Property of FCI. Copyright FCI.

mat'l. code		tolerances unless otherwise specified		CUSTOMER COPY		 www.fciconnect.com	
ltr	ecn no	dr	date	linear	.xx ±.01/.x±.3	projection	 title CONAN™ CONNECTOR ASSEMBLY
AA					.xxx ±.005/.xx±.13	 INCH/MM	
				angles	.xxx ±.0020/.xxx±.051		
				dr	0° ±2°	CONAN	code
				enr		size	213
				chr		scale	sheet
				appd		1:1	7 of 7
sheet index		revision sheet		cage code			