

521 Quick-Acting Miniature Fuse

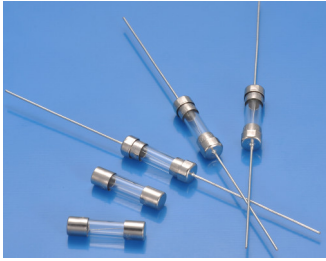

Main Characteristics

Cartridge Miniature fuse; Quick-Acting(F)

Standard

IEC 60127-2/ II

Materials

Tube: Glass Tube
End Caps: Nickel-plated brass
Axial Leads: Nickel-plated caps
Tin-plated copper wires

Operating Temperature

-55°C to +125°C

Storage Conditions

+10°C to +60°C
Relative humidity: ≤75% yearly average
without dew, maximum 30 days at 95%

Vibration Resistance

24 cycles at 15 min. each (60068-6)
10-60Hz at 0.75mm amplitude
60-2000Hz at 10g acceleration

Soldering Parameters

260°C. ≤5 sec (Wave Soldering)
350°C. ≤3 sec (Hand Soldering)
Soldering Peak:
260°C. 10 sec. (IEC 60068-20)

Average Time Current (I-T) Curves

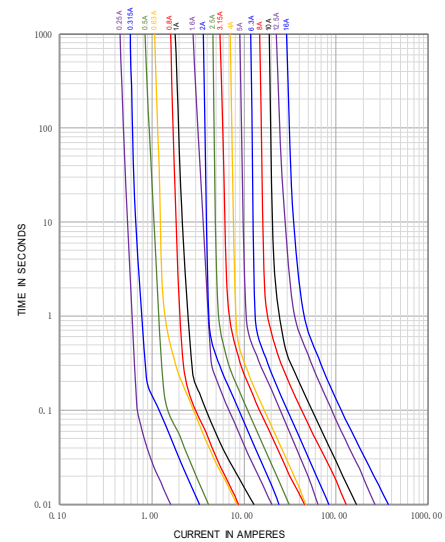

Dimensions (units in mm)

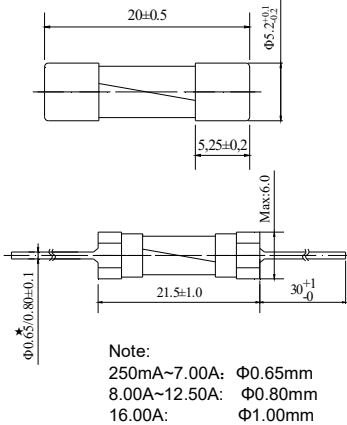

Time vs Current Characteristics: IEC 60127-2/ II					
Rated Current	150%	210%	275%	400%	1000%
250mA~6.3A	>1h	<30min	50ms~2s	10ms~300ms	≤20ms
8A~10A	>1h	<30min	50ms~2s	10ms~400ms	≤40ms
12.5A~16A	>30min	<30min	50ms~3s	10ms~400ms	≤50ms



Electrical Characteristics at 25°C												
Amp	Rated Current	Max Voltage	Max Voltage Drop (mV)	Max. Power Dissipation (W)	Nominal Melting I²t(A²sec)	Typical Code Resistance ±20%(ohms)	Breaking Capacity	Approvals				
								cURus	CQC	VDE	PSE	CCC
0250	250mA	250V AC	1400	1.6	0.0256	570	10kA/125VAC 100A/250VAC 50-60Hz Cosφ=0.7~0.8	○	○	○	○	○
0300	300mA		1300	1.6	0.1035	-		○	○	○	○	○
0315	315mA		1300	1.6	0.1089	860		●	○	●	○	●
0350	350mA		1300	1.6	0.1717	-		●	○	○	○	○
0375	375mA		1300	1.6	0.2085	-		●	○	○	○	○
0400	400mA		1200	1.6	0.24	540		●	○	○	○	●
0500	500mA		1000	1.6	0.1681	220		●	○	○	○	220
0630	630mA		650	1.6	0.7225	285		●	○	○	○	●
0750	750mA		240	1.6	0.813	-		●	○	○	○	○
0800	800mA		240	1.6	0.757	120		●	○	○	○	●
1100	1.00A		200	1.6	1.64	101		●	○	○	○	●
1125	1.25A		200	1.6	2.56	65.00		●	○	○	○	●
1150	1.50A		190	1.6	3.76	51.47		●	○	○	○	○
1160	1.60A		190	1.6	4.00	50.35		●	○	○	○	●
1200	2.00A		170	1.6	5.76	40.65		●	○	○	○	●
1250	2.50A		170	1.6	9.61	30.00		●	○	○	○	○
1300	3.00A		150	2.5	13.88	25.00		●	○	○	○	○
1315	3.15A		150	2.5	20.70	24.00		●	○	○	○	○
1350	3.50A		150	2.5	21.30	-		●	○	○	○	○
1400	4.00A		130	2.5	22.09	17.6		●	○	○	○	○
1500	5.00A		130	2.5	40.96	13.5		●	○	○	○	○
1630	6.30A		130	2.5	70.56	10.6		●	○	○	○	○
1700	7.00A		130	2.5	105.5	9.48		●	○	○	○	○
1800	8.00A		130	4	163.8	7.50		●	○	○	○	○
2100	10.00A		130	4	272.2	6.30		●	○	○	○	○
2125	12.50A		100	6	702.25	3.80		○	●	○	○	○
2160	16.00A		100	6	1332.3	3.10		○	○	●	○	○

Note: (1) Permissible continuous operating current is 100% at ambient temperature of 23°C (73.4°F)
(2) The cURus certification by 125V and 250V; the VDE certification with 8A~10A by 125V and 250V; the others certification by 250V.

Ordering Information

Series	Amp Code	Supplementary Code	Qty
521			