

2 SPECIFICATIONS FOR APPROVAL

Customer _____

Description Gas Tube Arrester

Customer's Part No. _____

Manufacturer DongGuan Better Electronics
Technology Co., Ltd.

Manufacturer's Part No. ARR-BM102M-CA8

Serial Number _____

Date March 22, 2011

Inspected By _____

Approved By _____

--

Customer's Approval

By _____

--

CONTENTS

	<i>Page</i>
1 Specifications & Dimension.....	1
2 Test Methods	2
2.1 DC Breakdown Voltage	2
2.2 Surge Breakdown Voltage	3
2.3 Life Test	4
2.3.1 AC Discharge Current.....	4
2.3.2 Surge Discharge Current	5
2.4 Insulation Resistance.....	5
2.5 Capacitance	5

1. Specifications & Dimension

1.1. Parts No.:

ARR-BM102M-CA8

1.2. Specifications:

- DC Breakdown Voltage: (@rising voltage 100V/s)
800-1200V @Initial
750-1250V @After life tests
- Surge Breakdown Voltage: (@rising voltage 1000V/ μ s)
<1500V @Initial
<1600V @After life tests
- Insulation Resistance: (@DC 500V)
 $\geq 10000M\Omega$ @Initial
 $\geq 100M\Omega$ @After life tests
- Electrode Capacitance: (@1MHz)
<1.5 PF @Initial
<1.5 PF @After life tests
- Life Tests:
 - AC Discharge Current: 10A (10 times, 1s per time with 3mins interval)
 - Surge Discharge Current:
100A (10/1000 μ s, 300times with 3mins interval)
10kA (8/20 μ s, 10times with 3mins interval)
- No radio-active materials used

1.3. Dimension: (unit: mm)

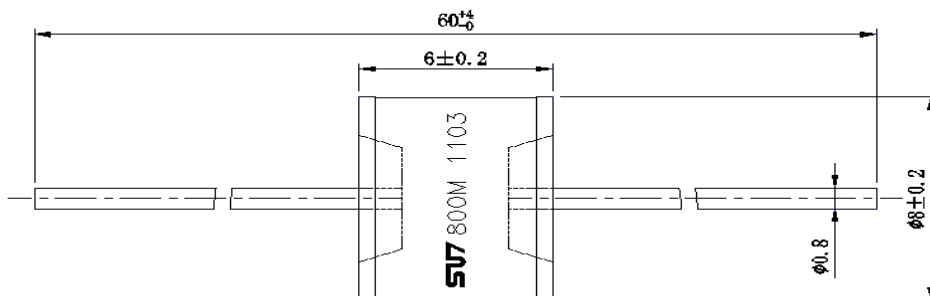

2. Test Methods

2.1. DC Breakdown Voltage:

The test circuit is indicated in Figure 1. Typically, the power supply offers a rate of rising voltage at 100 V/s. The tolerances on the wave-shape of the rising test voltage are shown in Figure 2. The voltage is measured across the open-circuited terminals of the power supply. V_{max} of Figure 2 is any voltage that greater than the maximum and less than three times the minimum DC breakdown voltage of the gas tube.

Each pair of terminals of a 3-electrode gas tube shall be tested separately with the other terminal unterminated.

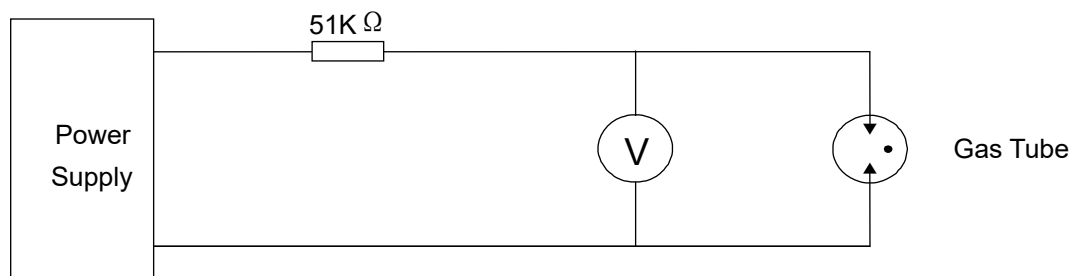

Figure 1. DC Breakdown Voltage Test Circuit

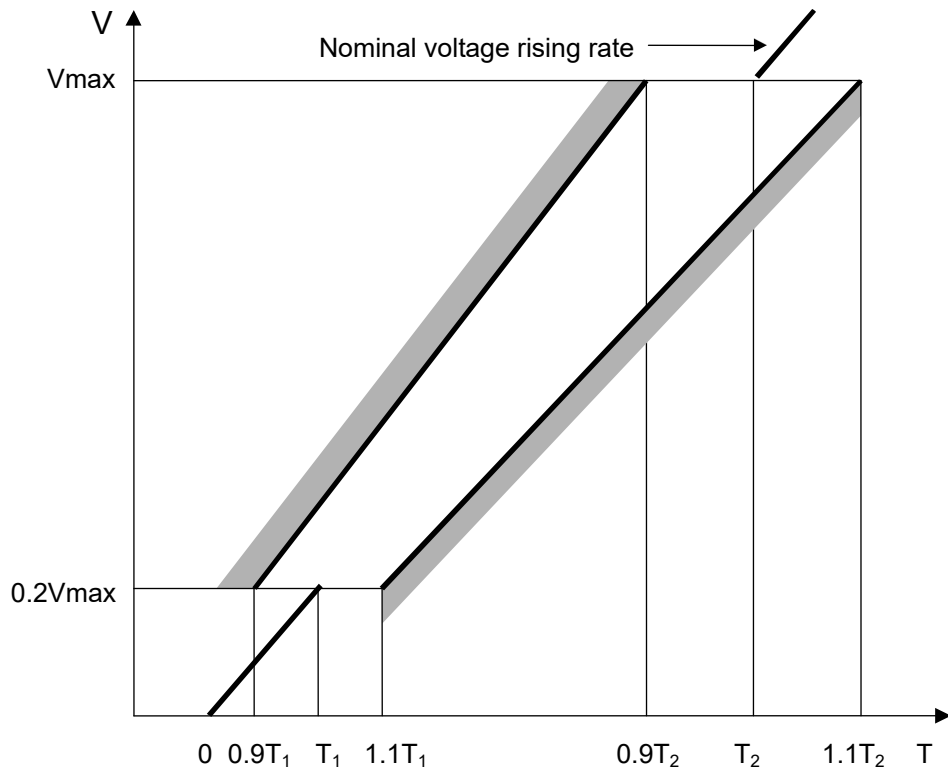

Figure 2. DC Breakdown Voltage Test Waveform

2.2. Surge Breakdown Voltage:

The nominal rising rate of the test voltage is $1000\text{V}/\mu\text{s}$ and should follow the waveform and limits shown in Figure 2. Figure 3. Shows the arrangement for testing with a surge having a nominal rate of rise of $1000\text{V}/\mu\text{s}$.

Each pair of terminals of a 3-electrode gas tube shall be tested separately with the other terminal unterminated.

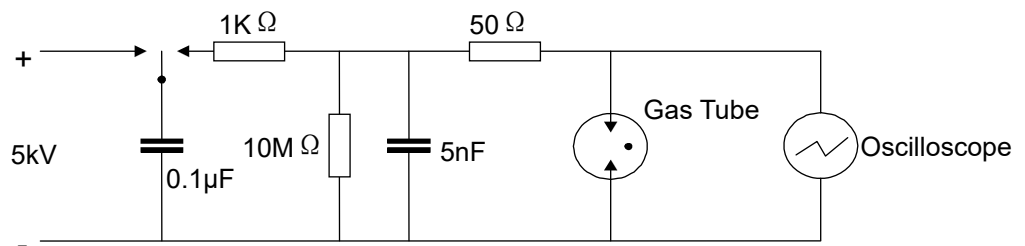

Figure 3. Surge Breakdown Voltage Test Circuit

2.3. Life Tests:

Table 1. indicates the nominal discharge current rating of the gas tube. After the completion of life test, the insulation resistance should be not less than nominal insulation resistance divided by 10. Also, DC and Surge breakdown voltage should follow nominal values.

Nominal current	AC 50 Hz for 1s with 3mins interval		Surge current 10/1000 μ s, 300 times,	Surge current 8/20 μ s, 10 times
	A rms	Test times	A peak	kA peak
2.5	2.5	10	50	2.5
5	5	10	100	5
10	10	10	100	10
20	20	10	200	20

Table1. Life Tests Current Rating

2.3.1. AC Discharge Current:

Gas tube should be tested under the relevant current and times indicated in Table1. The ACrms voltage of the AC power supply shall exceed the maximum DC breakdown voltage of the gas tube by not less than 50 per cent.

After the completion of AC discharge current tests, the gas tube shall be allowed to cool down in ambient temperature for more than 24 hours and tested for compliance with 2.3.

The test circuit is shown in Figure 4. and Figure 5.

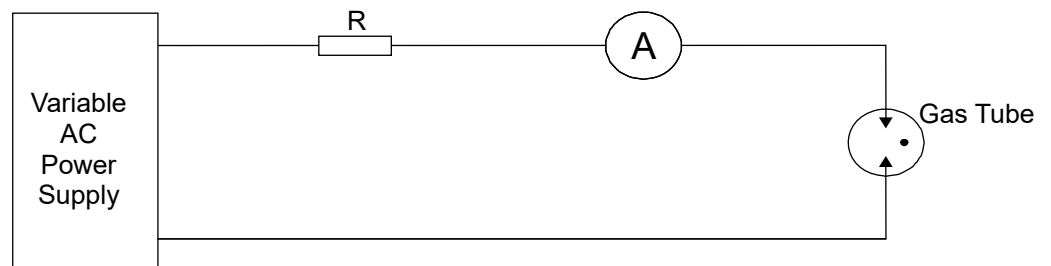

R: Current limit resistance

Figure 4. AC Discharge Current Test Circuit for 2-Eletrode Gas Tube

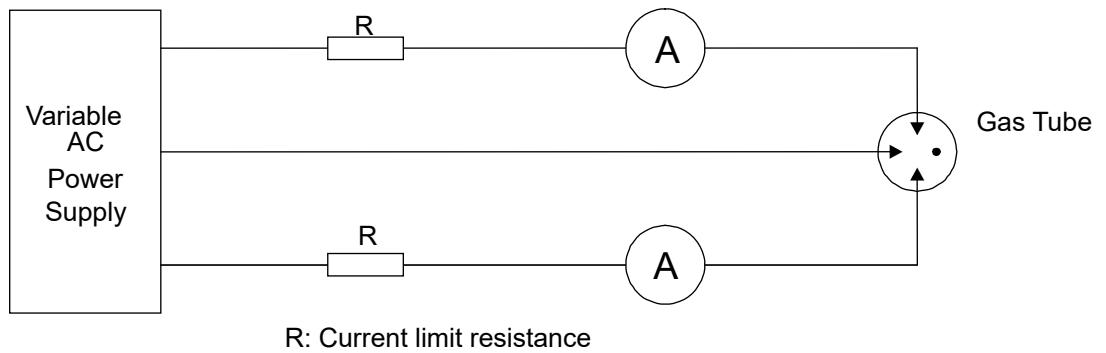

Figure 5. AC Discharge Current Test Circuit for 3-Electrode Gas Tube

2.3.2. Surge Discharge Current:

Gas tube should be tested under the relevant current and times indicated in Table 1. Half the test times shall be carried out with one polarity and half with the opposite polarity. Or, half the tubes may be tested with one polarity and the other half with the opposite polarity. The surge voltage of the surge generator shall exceed the maximum Surge breakdown voltage of the gas tube by not less than 50 per cent.

After the completion of surge discharge current tests, the gas tube shall be allowed to cool down in ambient temperature for more than 24 hours and tested for compliance with 2.3.

For 3-electrode gas tubes, independent surge shall be discharged simultaneously from each electrode to the ground electrode.

2.4. Insulation Resistance:

The measurement shall be applied at DC 500V and not more than 90% of the minimum nominal DC breakdown voltage. The insulation resistance shall be measured from each electrode to every other electrode. The power source shall be limited to a short circuit current of less than 10 mA.

2.5. Capacitance:

The capacitance shall be measured between each terminal and every other terminal of the gas discharge tube. In measurements involving 3-electrode gas discharge tubes, the terminal not being tested shall be connected to a ground plane in the measuring instrument.