





DATA IMAGE CORPORATION

LCD Module Specification

ITEM NO.: CM080200NRNNA-01

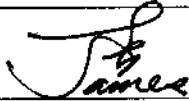
Table of Contents

1. COVER & CONTENTS	1
2. RECORD OF REVISION	2
3. GENERAL SPECIFICATIONS	3
4. ABSOLUTE MAXIMUM RATINGS	4
5. ELECTRICAL CHARACTERISTICS	6
6. ELECTRO-OPTICAL CHARACTERISTIC	6
7. TIMING CHARACTERISTICS	8
8. PIN CONNECTIONS	10
9. POWER SUPPLY	10
10. BLOCK DIAGRAM	11
11. QUALITY ASSURANCE	18
12. LOT NUMBERING SYSTEM	22
13. LCM NUMBERING SYSTEM	22
14. PRECAUTIONS IN USE LCM	23
15. OUTLINE DRAWING	24
16. PACKAGE INFORMATION.....	25

R&D Dept.	Q.C. Dept.	Eng. Dept.	Prod. Dept.
			
Version:	Issued Date:	Sheet Code:	Total Pages:
	2002/7/9		25

2. RECORD OF REVISION

Rev	Date	Item	Page	Comment
	JUL/9/02	13	22	Change: P/N from CM0820NR-J2 to CM080200NRNNA-01

3. GENERAL SPECIFICATION

- Display Format : 8characters (W) × 2lines (H)
- Character Size : 2.945 (W) × 5.545 (H) mm
- View Area : 35 (W) × 16 (H) mm
- General Dimensions : 58 (W) × 32 (H) × 10 (T) mm Max.
- Weight : 18 g max.
- LCD Type : STN Gray STN Yellow FSTN TN
- Polarizer mode : Reflective Transflective
- Transmissive Negative
- View Angle : 6 O'clock 12 O'clock Others _____
- Backlight : LED EL CCFL
- Backlight Color : Yellow green Amber Blue Green
- White Others
- Controller / Driver : KS0066
- Temperature Range : Normal Wide Temperature
- | | | | |
|-----------|-------------|-----------|-------------|
| Operating | 0 to 50°C | Operating | -20 to 70°C |
| Storage | -20 to 70°C | Storage | -30 to 80°C |

4. ABSOLUTE MAXIMUM RATINGS

4.1 ELECTRICAL ABSOLUTE MAXIMUM RATINGS

$V_{SS}=0V$, $T_a = 25^{\circ}C$

Item	Symbol	Min.	Max.	Unit
Supply Voltage (Logic)	$V_{DD}-V_{SS}$	0	7	V
Supply Voltage (LCD Driver)	$V_{DD}-V_{EE}$	1.5	13.5	V
Input Voltage	V_I	V_{SS}	V_{DD}	V
Operating Temperature	T_{OP}	0	50	$^{\circ}C$
Storage Temperature	T_{STG}	-20	70	$^{\circ}C$

4.2 ENVIRONMENTAL ABSOLUTE MAXIMUM RATINGS

Item	Operating		Storage		Comment
	(Min.)	Max.)	(Min.)	(Max.)	
Ambient Temp	0	50	-20	70	Note (1)
Humidity	Note (2)		Note(2)		Without Condensation
Vibration	--	4.9M/S ²	--	19.6M/S ²	XYZ Direction
Shock	--	29.4M/S ²	--	490M/S ²	XYZ Direction

Note(1) $T_a = 0^{\circ}C$: 50Hr Max.

Note(2) $T_a \leq 40^{\circ}C$: 90% RH Max.

$T_a \geq 40^{\circ}C$: Absolute humidity must be lower than the humidity of 90% RH at $40^{\circ}C$.

4. 3 Electronic Static Discharge maximum rating

ESD test method : IEC1000-4-2

Item	Description	
Testing environment	Ambient temperature :15°C to 35 °C Humidity: 30% to 60 % LCM (E.U.T) : Power up	
Testing equipment	Manufacture: NoiseKen, Model No. ESD-100L	
Testing condition	See drawing 1	
Direct discharge	0 to ± 6 KV	Discharge point, see drawing 2
Indirect discharge	0 to ± 12KV	Discharge point, see drawing 1
Pass condition	No malfunction of unit. Temporary malfunction of unit which can be recovered by system reset	
Fail condition	Non. Recoverable malfunction of LCM or system	

FIG 1 ESD TESTING EQUIPMENT

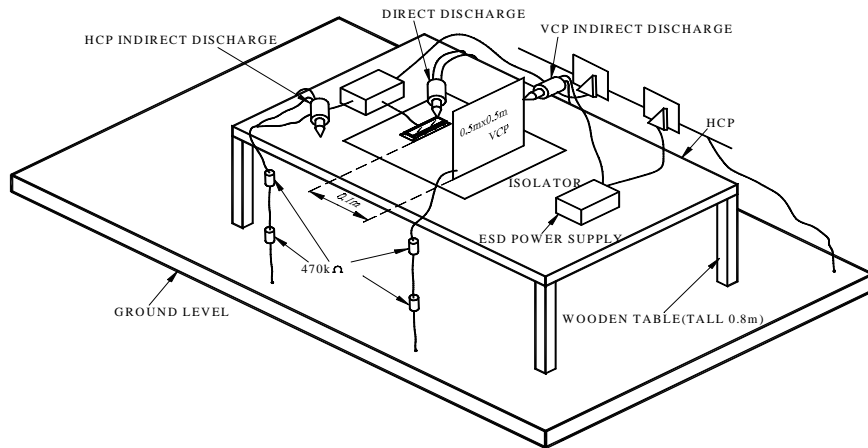

(1)

DIRECT CONTACT DISCHARGE

CONTACT POINT : A.B.C.D

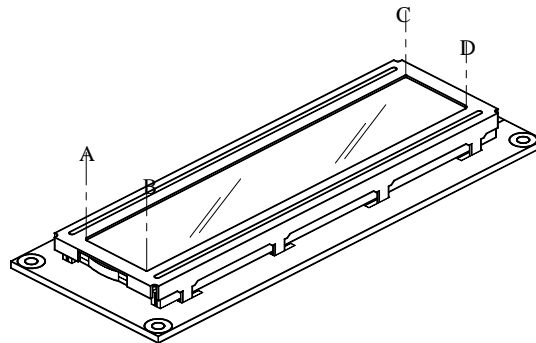

(2)

5. ELECTRICAL CHARACTERISTICS

Item	Symbol	Condition	Min.	Typ.	Max.	Unit
Supply Voltage (Logic)	VDD-VSS		2.7	5.0	5.5	V
Supply Voltage (LCD)	VDD-VEE	0°C	4.3	4.5	4.7	V
		25°C	4.1	4.3	4.5	
		50°C	3.6	3.8	4.0	
Input Voltage	V _{IH}	--	0.7*VDD	--	VDD	V
	V _{IL}		VSS	--	0.3*VDD	
Logic Supply Current	I _{DD}	VDD-VSS=5V	--	1.0	--	mA

6. ELECTRO-OPTICAL CHARACTERISTICS

ITEM	Symbol	Condition	Min.	Typ.	Max.	Unit	Ref.
Rise Time	Tr	0°C	--	300	500	ms	Note (1)
		25°C		100	200		
Fall Time	Tf	0°C	--	500	850	ms	
		25°C		150	300		
Contrast	CR	25°C	2	4	--		Note (3)
View Angle	θ _{1-θ2} ∅ _{1, ∅2}	25°C & CR≥2	--	80	--		Note (2)
			--	30	--		
Frame Frequency	Ff	25°C	--	64	--	Hz	

Note (1) & (2) : See next page

Note (3) : Contrast ratio is defined under the following condition:

$$CR = \frac{\text{Brightness of non-selected condition}}{\text{Brightness of selected condition}}$$

- (a). Temperature ----- 25°C
- (b). Frame frequency ---- 64Hz
- (c). Viewing angle ----- θ= 0°, ∅ = 0°
- (d). Operating voltage --- 4.3V

Note (1) Response time is measured as the shortest period of time possible between the change in state of an LCD segment as demonstrated below:

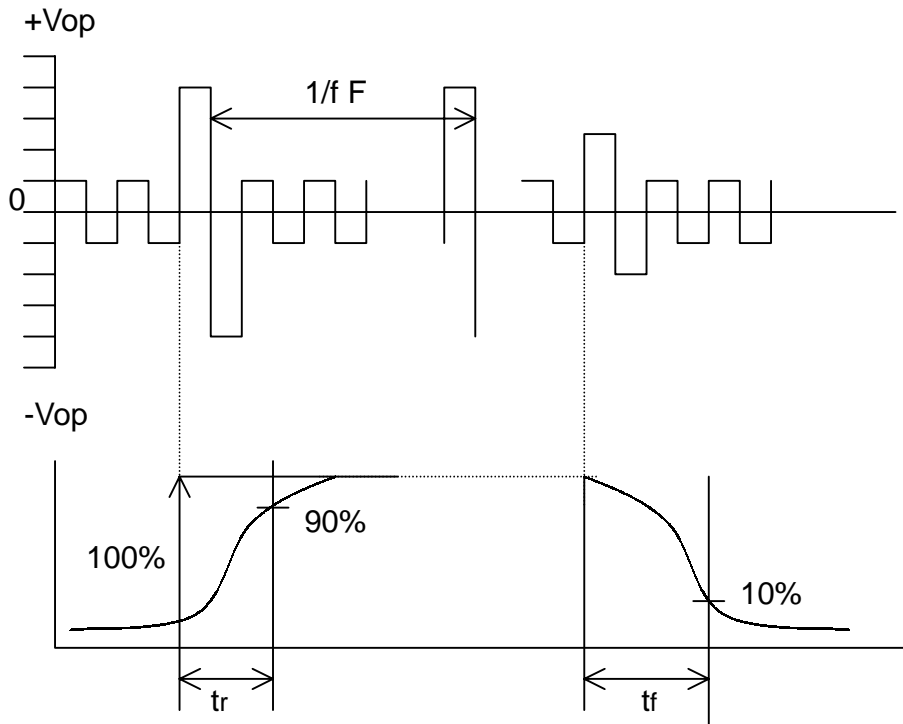

Condition:

- (a) . Temperature ----- $25^{\circ}C$
- (b) . Frame frequency ----- 64Hz
- (c) . View Angle ----- $\theta = 0^{\circ}$, $\phi = 0^{\circ}$
- (d) . Operating voltage ----- 4.3V

Note (2) Definition of View Angle

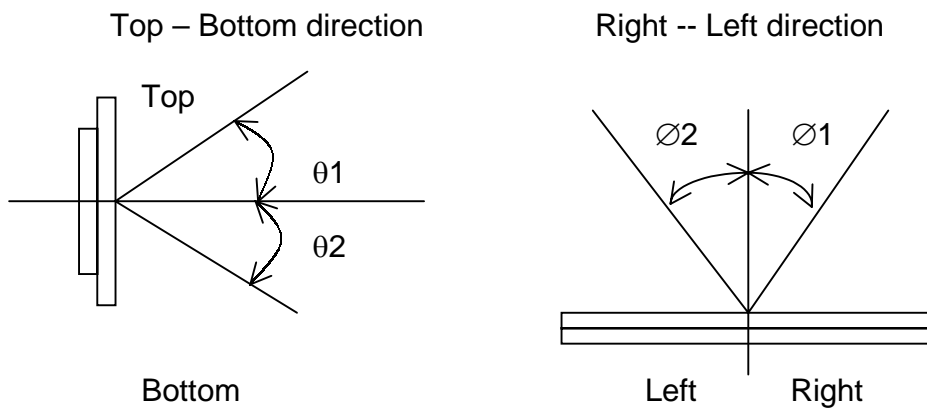

7. TIMING CHARACTERISTICS

7.1 WRITE TIMING

AC characteristics (VDD=4.5v~5.5v, Ta=-30~85°C)

Item	Symbol	Condition	Min.	Max.	Unit
E cycle time	tc	VDD = 5V	500	--	ns
E pulse width (high level)	tw		230	--	
E rise/fall time	tR, tF		--	20	
R/W and RS Setup time	tsu1		40	--	
R/W and RS Hold time	tH1		10	--	
Data setup time	tsu2		80	--	
Data hold time	tH2		10	--	

AC characteristics (VDD=2.7v~4.5v, Ta=-30~85°C)

Item	Symbol	Condition	Min.	Max.	Unit
E cycle time	tc	VDD = 3V	1000	--	ns
E pulse width (high level)	tw		450	--	
E rise/fall time	tR, tF		--	25	
R/W and RS Setup time	tsu1		60	--	
R/W and RS Hold time	tH1		20	--	
Data setup time	tsu2		195	--	
Data hold time	tH2		10	--	

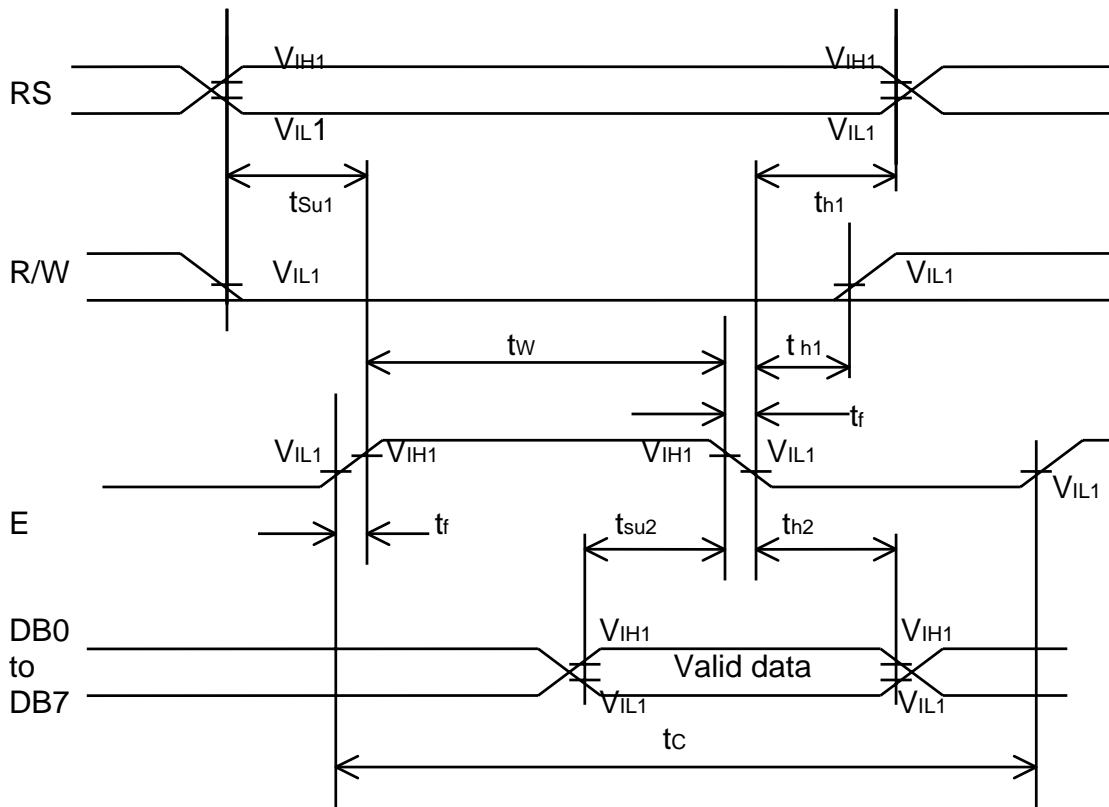

7.2 READ TIMING

AC characteristics (VDD=4.5v~5.5v, Ta=-30~85°C)

Item	Symbol	Condition	Min.	Max.	Unit
E cycle time	tc	VDD = 5V	500	--	ns
E pulse width (high level)	tw		230	--	
E rise/fall time	tR, tF		--	20	
R/W and RS shetup time	tsu		40	--	
R/W and RS hold time	tH		10	--	
Data output delay time	tD		--	120	
Data hold time	tDH		5	--	

AC characteristics (VDD=2.7v~4.5v, Ta=-30~85°C)

Item	Symbol	Condition	Min.	Max.	Unit
E cycle time	tc	VDD = 3V	1000	--	ns
E pulse width (high level)	tw		450	--	
E rise/fall time	tR, tF		--	25	
R/W and RS setup time	tsu		60	--	
R/W and RS hold time	tH		20	--	
Data output delay time	tD		--	--	
Data hold time	tDH		5	--	

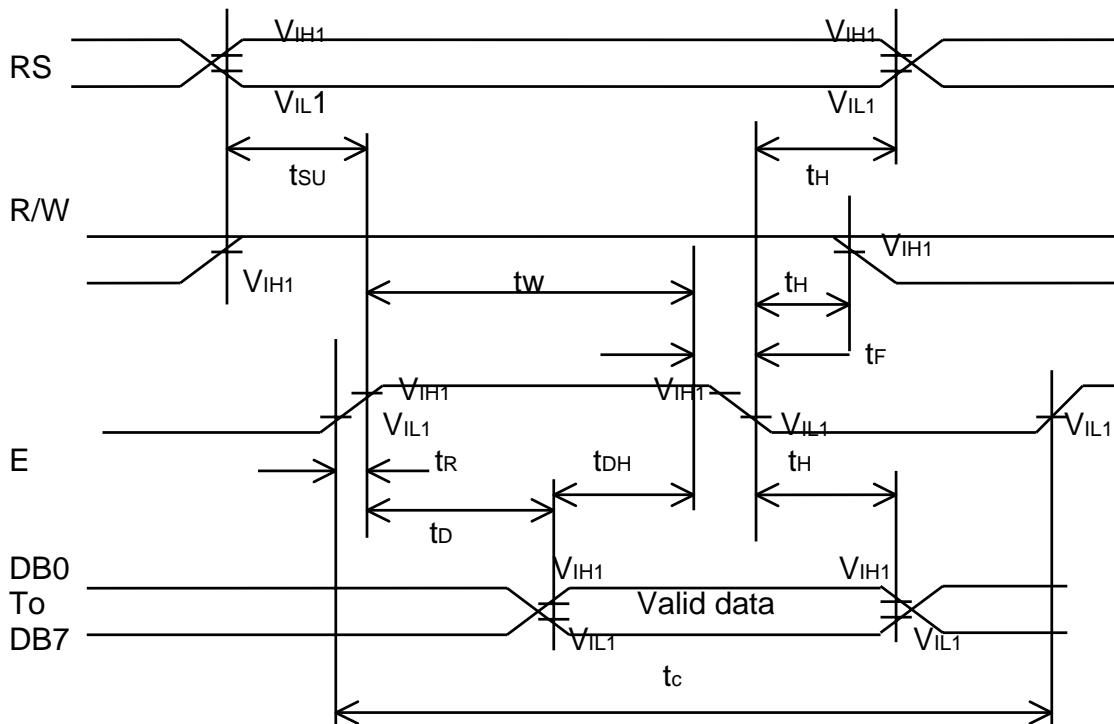

8. PIN CONNECTIONS

No.	Symbol	Function
1	VSS	Ground, 0V
2	VDD	Logic power supply, +5V
3	VEE	Voltage for LCD drive
4	RS	Data / Instruction register select
5	R/W	Read / Write
6	E	Enable signal, start data read/write
7	DB0	Data Bus Line
8	DB1	
9	DB2	
10	DB3	
11	DB4	
12	DB5	
13	DB6	
14	DB7	
15	LED A	LED Anode, power supply +
16	LED K	LED Cathode, ground 0V

9. POWER SUPPLY

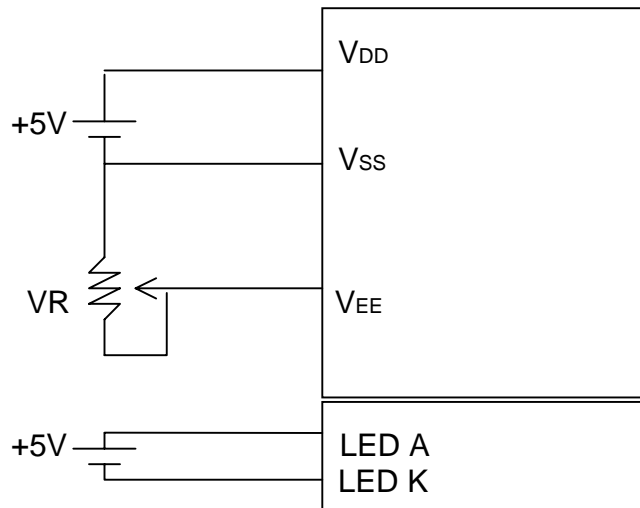

VR = 10K

10. BLOCK DIAGRAM

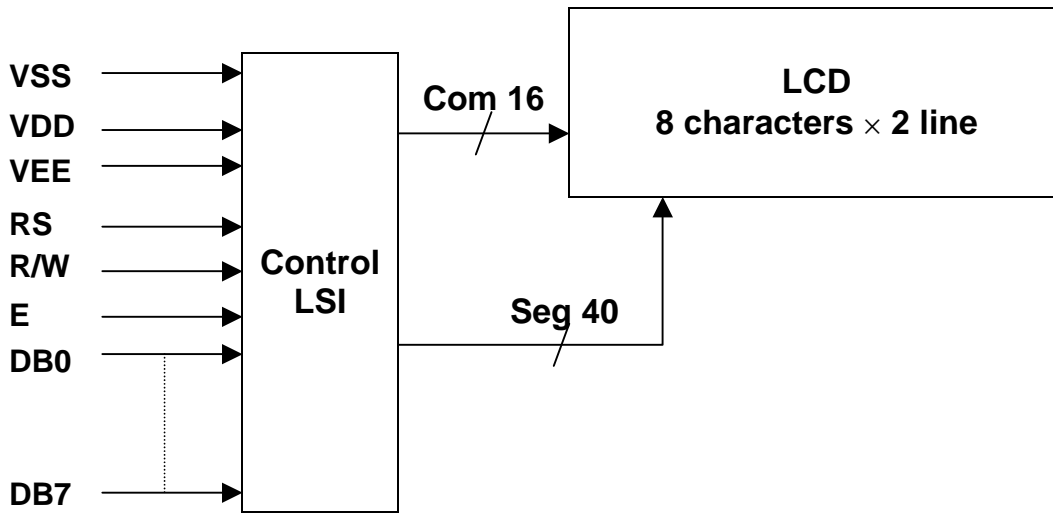

10.1 INSTRUCTIONS

Instruction	Instruction Code										DESCRIPTION	Executed Time(fosc =270KHz)
	RS	R/W	DB7	DB6	DB5	DB4	DB3	DB2	DB1	DB0		
Clear Display	0	0	0	0	0	0	0	0	0	1	Write "20H" to DDRAM and set DDRAM address to "00H" from AC	1.53mS
Cursor At Home	0	0	0	0	0	0	0	0	1	-	Set DDRAM address to "00H" from AC and return cursor to its original Position if shifted. The contents of DDRAM are not changed.	1.53mS
Entry Mode Set	0	0	0	0	0	0	0	1	I/D	SH	Assign cursor moving direction and enable the shift of entire display.	39μS
Display On/Off Control	0	0	0	0	0	0	1	D	C	B	Set display (D), cursor(C), and Blinking of cursor(B) ON/OFF control bit.	39μS
Cursor or Display Shift	0	0	0	0	0	1	S/C	R/L	-	-	Set cursor moving and display shifts cursor bit, and the direction, without changing of DDRAM data.	39μS
Function Set	0	0	0	0	1	DL	N	F	-	-	Sets interface data length (DL:8-BIT/4-BIT), number of display lines(N:2-line/1-line) and, display font type (F:5x11dots/5x8 dots).	39μS
Set CGRAM Address	0	0	0	1	AC5	AC4	AC3	AC2	AC1	AC0	Set CGRAM address in address counter.	39μS
Set DDRAM Address	0	0	1	AC6	AC5	AC4	AC3	AC2	AC1	AC0	Set DDRAM address in address counter.	39μS
Read Busy Flag and Address	0	1	BF	AC6	AC5	AC4	AC3	AC2	AC1	AC0	Whether during internal operation or not can be known by reading BF. The contents of address counter can also be read.	0μS
Write Data to RAM	1	0	D7	D6	D5	D4	D3	D2	D1	D0	Write data into internal RAM (DDRAM / CGRAM)	43μS
Read Data from RAM	1	1	D7	D6	D5	D4	D3	D2	D1	D0	Reads data from internal RAM (DDRAM / CGRAM).	43μS

*"-":don't care

NOTE : When an MPU program with checking the Busy Flag(DB7) is made, it must be necessary 1/2Fosc is necessary for executing the next instruction by the falling edge of the 'E' signal after the Busy Flag(DB7) goes to "LOW" .

10.2 8-Bit Operation, 8-Digit×2-Line Display Example

Step	Instruction										Display	Operation
	No	RS	R/W	DB7	DB6	DB5	DB4	DB3	DB2	DB1		
1	Power supply on (the HD44780U is initialized by the Internal reset circuit)											Initialized. No display.
2	Function set 0 0 0 0 1 1 1 0 * *											Sets to 8-bit operation and selects 2-line display and 5×8 dot character font.
3	Display on/off control 0 0 0 0 0 0 1 1 1 0											Turns on display and cursor. All display is in space mode because of initialization.
4	Entry mode set 0 0 0 0 0 0 0 1 1 0											Sets mode to increment the address by one and to shift the cursor to the right at the time of write to the DD/CGRAM. Display is not shifted.
5	Write data to CGRAM/DDRAM 1 0 0 1 0 0 1 0 0 0											Writes H. DDRAM has already been selected by initialization when the power was turned on. The cursor is incremented by one and shifted to the right
6	⋮										⋮	
7	Write data to CGRAM/DDRAM 1 0 0 1 0 0 1 0 0 1											Writes I.
8	Set DDRAM address 0 0 1 1 0 0 0 0 0 0											Sets DDRAM address so that t The cursor is positioned at the Head of the second line.
9	Write data to CGRAM/DDRAM 1 0 0 1 0 0 1 1 0 1											Writes M.
10	⋮										⋮	
11	Write data to CGRAM/DDRAM 1 0 0 1 0 0 1 1 1 1											Writes O.
12	Entry mode set 0 0 0 0 0 0 0 1 1 1											Sets mode to shift display at the time of write.
13	Write data to CGRAM/DDRAM 1 0 0 1 0 0 1 1 0 1											Writes M. Display is shifted to the left. The first and second lines both shift at the same time.
14	⋮										⋮	
15	Return home 0 0 0 0 0 0 0 0 1 0											Returns both display and cursor to the original position (address 0).

10.3 Interfacing to the MPU

The HD44780U can send data in either two 4-bit operations, thus allowing interfacing with 4- or 8-bit MPUs.

- For 4-bit interface data, only four bus lines (DB4 to DB7) are used for transfer. Bus lines DB0 to DB3 are disabled. The data transfer between the HD44780U and the MPU is completed after the 4-bit data has been transferred twice. As for the order of data transfer, the four high order bits (for 8-bit operation, DB4 to DB7) are transferred before the four low order bits (for 8-bit operation, DB0 to DB3). The busy flag must be checked (one instruction) after the 4-bit data has been transferred twice. Two more 4-bit operations then transfer the busy flag and address counter data.

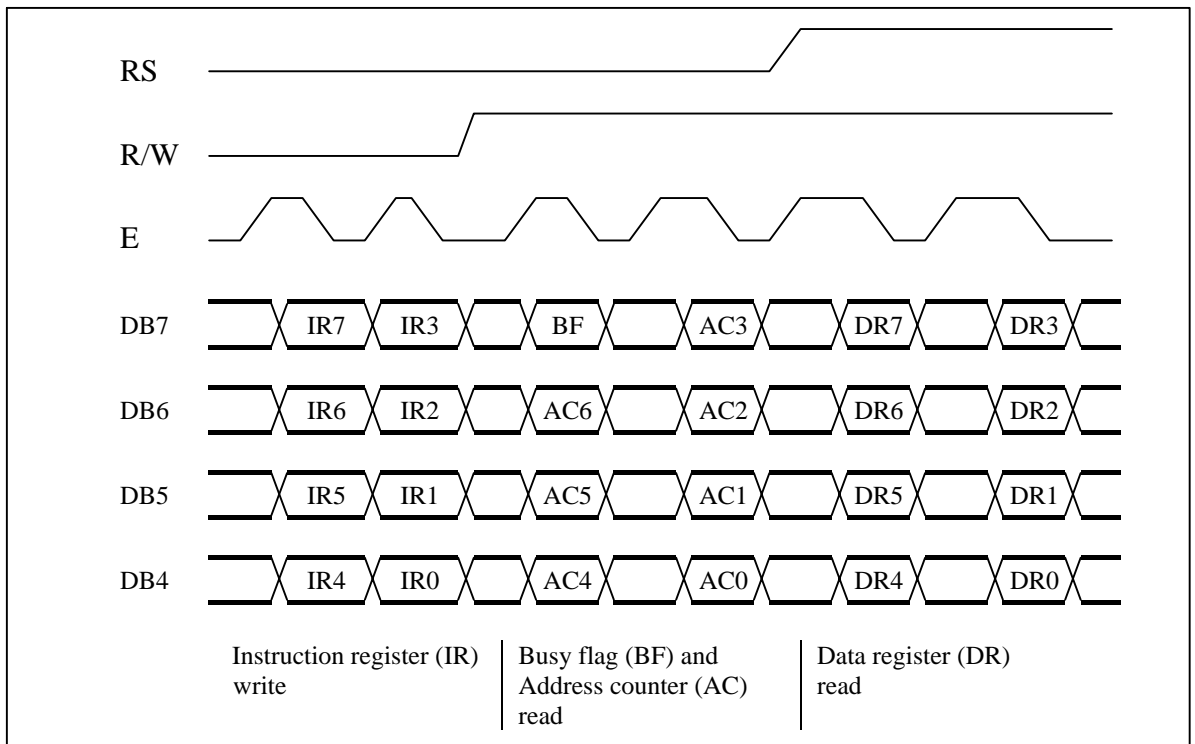

4-Bit Transfer Example

10.4 1-Line Display

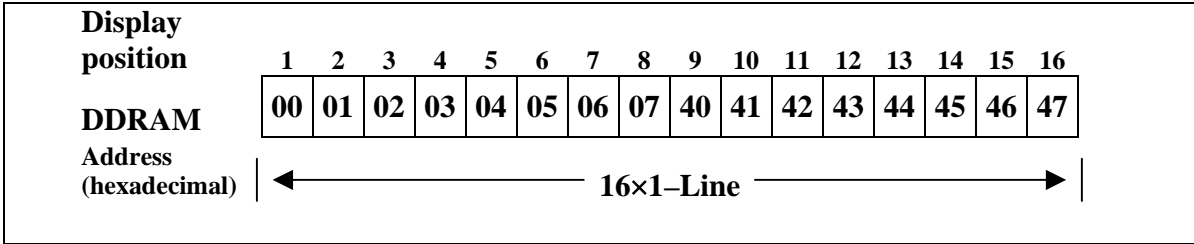

2-Line Display

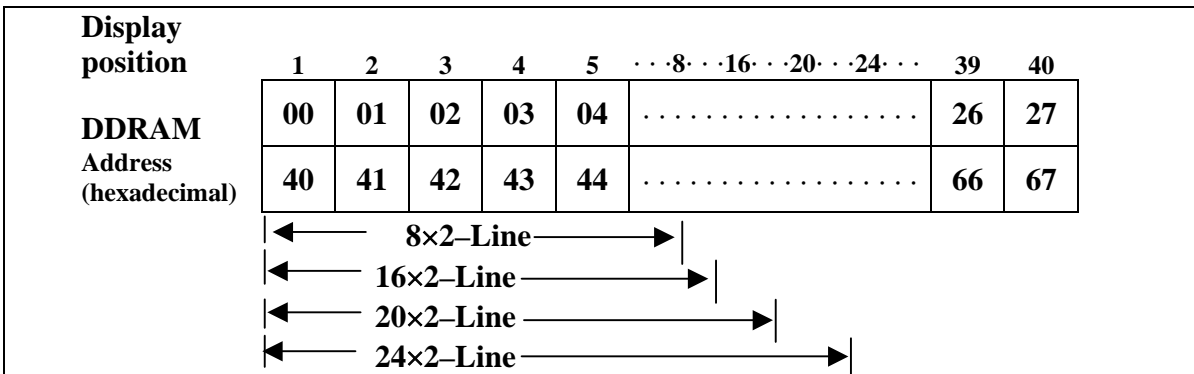

4-Line Display

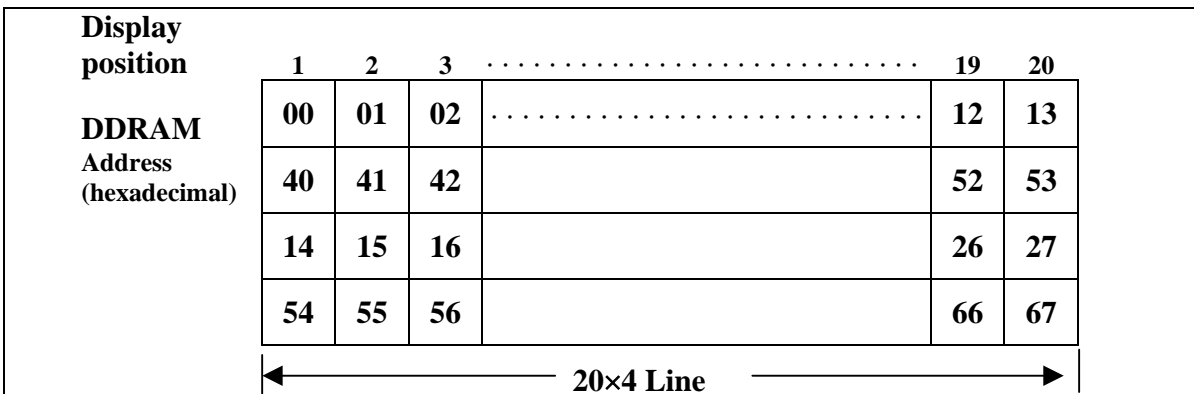
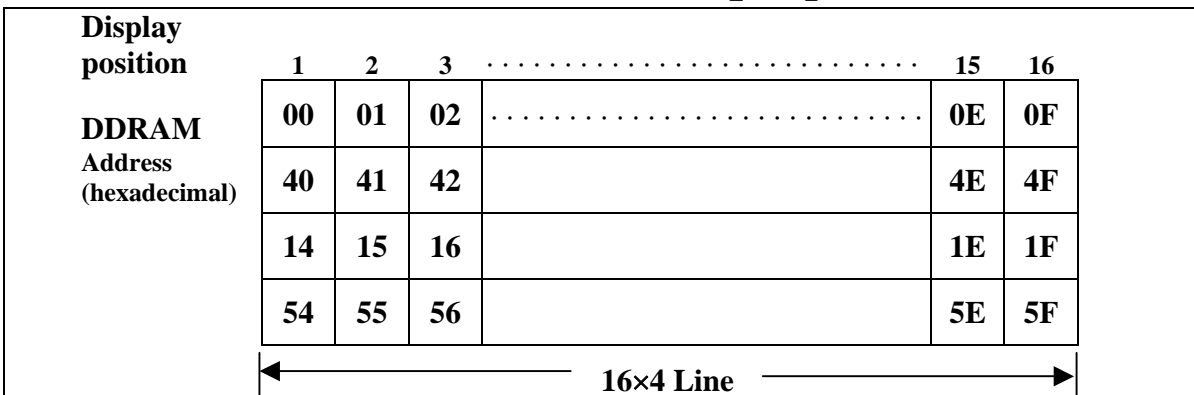

10.5 CGRAM

Relationship between CGRAM Addresses, Character Codes (DDRAM) and Patterns (CGRAM Data)

For 5x8 dot character patterns

Character Codes (DDRAM data)		CGRAM Address		Character Patterns (CGRAM data)	
7 6 5 4 3 2 1 0		5 4 3 2 1 0		7 6 5 4 3 2 1 0	
High Low		High Low		High Low	
0 0 0 0 * 0 0 0		0 0 0	0 0 0	** * 1 1 1 1 0	Character Pattern (1)
			0 0 1	1 0 0 0 1	
			0 1 0	1 0 0 0 1	
			0 1 1	1 1 1 1 0	
			1 0 0	1 0 1 0 0	
			1 0 1	1 0 0 1 0	Cursor position
			1 1 0	1 0 0 0 1	
			1 1 1	** * 0 0 0 0 0	
0 0 0 0 * 0 0 1		0 0 1	0 0 0	** * 1 0 0 0 1	Character Pattern (2)
			0 0 1	0 1 0 1 0	
			0 1 0	1 1 1 1 1	
			0 1 1	0 0 1 0 0	
			1 0 0	1 1 1 1 1	
			1 0 1	0 0 1 0 0	Cursor position
			1 1 0	0 0 1 0 0	
			1 1 1	** * 0 0 0 0 0	
			0 0 0	** *	Cursor position
			0 0 1	** *	
0 0 0 0 * 1 1 1		1 1 1	1 0 0	** *	
			1 0 1	** *	

- Notes :
- Character code bits 0 to 2 correspond to CGRAM address bits 3 to 5 (3 bits: 8 types).
 - CGRAM address bits 0 to 2 designate the character pattern line position. The 8th line is the cursor position and its display is formed by a logical OR. Maintain the 8th line data, corresponding to the cursor display position, at 0 as the cursor display. If the 8th line data is 1, 1 bits will light up the 8th line regardless of the cursor presence.
 - Character pattern row positions correspond to CGRAM data bits 0 to 4 (bit 4 being at the left).
 - As shown Table 5, CGRAM character patterns are selected when character code bits 4 to 7 are all 0. However, since character code bit 3 has no effect, the R display example above can be selected by either character code 00H or 08H.
 - 1 for CGRAM data corresponds to display selection and 0 to non-selection.
- * Indicates no effect.

10.6 Correspondence between Character Codes and Character Patterns (ROM Code:A00)

Upper Lower LCRAM RAM	0000	0001	0010	0011	0100	0101	0110	0111	1000	1001	1010	1011	1100	1101	1110	1111
xxxx0000	CG RAM (1)			0	a	P	`	P				-	夕	ミ	α	ρ
xxxx0001	(2)		!	1	A	Q	a	q			。	ア	チ	△	ä	q
xxxx0010	(3)		"	2	B	R	b	r			「	イ	ツ	×	β	θ
xxxx0011	(4)		#	3	C	S	c	s			」	ウ	テ	モ	ε	∞
xxxx0100	(5)		\$	4	D	T	d	t			、	エ	ト	ト	μ	Ω
xxxx0101	(6)		%	5	E	U	e	u			・	オ	ナ	工	ε	Ü
xxxx0110	(7)		&	6	F	V	f	v			ヲ	カ	ニ	ヨ	ρ	Σ
xxxx0111	(8)		'	7	G	W	g	w			フ	キ	ヌ	ラ	g	π
xxxx1000	(1)		(8	H	X	h	x			ィ	ク	ネ	リ	フ	×
xxxx1001	(2))	9	I	Y	i	y			ウ	ケ	ル	ル	”	y
xxxx1010	(3)		*	:	J	Z	j	z			エ	コ	ン	レ	j	≠
xxxx1011	(4)		+	;	K	C	k	c			オ	サ	ヒ	ロ	*	π
xxxx1100	(5)		,	<	L	¥	l	l			カ	シ	フ	ワ	φ	π
xxxx1101	(6)		-	=	M	J	m	j			ユ	ス	ン	ン	も	÷
xxxx1110	(7)		.	>	N	^	n	→			ヨ	セ	ホ	”	π	
xxxx1111	(8)		/	?	O	_	o	←			ッ	ソ	マ	°	ö	■

Note: The user can specify any pattern for character-generator RAM.

11. QUALITY ASSURANCE

11.1 Test Condition

11.1.1 Temperature and Humidity(Ambient Temperature)

Temperature : $20 \pm 5^{\circ}\text{C}$

Humidity : $65 \pm 5\%$

11.1.2 Operation

Unless specified otherwise, test will be conducted under function state.

11.1.3 Container

Unless specified otherwise, vibration test will be conducted to the product itself without putting it in a container.

11.1.4 Test Frequency

In case of related to deterioration such as shock test. It will be conducted only once.

11.1.5 Test Method

No.	Parameter	Conditions	Regulations
1	High Temperature Operating	$50 \pm 2^{\circ}\text{C}$	Note 3
2	Low Temperature Operating	$0 \pm 2^{\circ}\text{C}$	Note 3
3	High Temperature Storage	$70 \pm 2^{\circ}\text{C}$	Note 3
4	Low Temperature Storage	$-20 \pm 2^{\circ}\text{C}$	Note 3
5	Vibration Test (Non-operation state)	Total fixed amplitude : 1.5mm Vibration Frequency : 10 ~ 55Hz One cycle 60 seconds to 3 directions of X.Y.Z. for each 15 minutes	Note 3
6	Damp Proof Test (Non-operation state)	$40^{\circ}\text{C} \pm 2^{\circ}\text{C}$, 90~95%RH, 96h	Note 1,2
7	Shock Test (Non-operation state)	To be measured after dropping from 60cm high once concrete surface in packing state	Note 3

Note 1: Returned under normal temperature and humidity for 4 hrs.

Note 2: No dew condensation to be observed.

Note 3: No change on display and in operation under the test condition

11.2 Inspection condition

11.2.1 Inspection conditions

The LCD shall be inspected under 40W white fluorescent light.

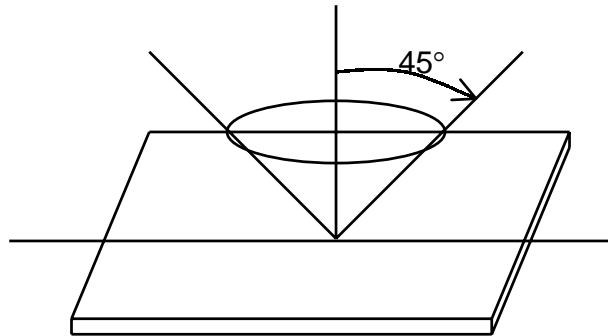

11.2.2 Definition of applicable Zones

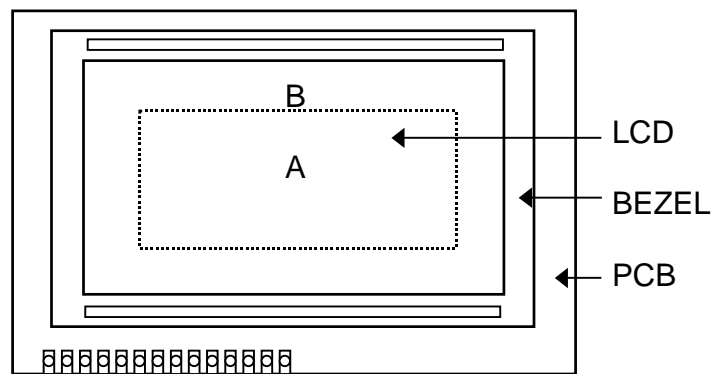

A : Display Area
B : Non-Display Area

11.2.3 Inspection Parameters

No.	Parameter	Criteria																												
1	Black or White spots	<table border="1"> <thead> <tr> <th rowspan="2">Zone Dimension</th> <th colspan="2">Acceptable number</th> <th rowspan="2">Class Of Defects</th> <th rowspan="2">AQL Level</th> </tr> <tr> <th>A</th> <th>B</th> </tr> </thead> <tbody> <tr> <td>D < 0.15</td> <td>*</td> <td>*</td> <td rowspan="4">Minor</td> <td rowspan="4">2.5</td> </tr> <tr> <td>0.15 ≤ D < 0.2</td> <td>4</td> <td>4</td> </tr> <tr> <td>0.2 ≤ D ≤ 0.25</td> <td>2</td> <td>2</td> </tr> <tr> <td>D ≤ 0.3</td> <td>0</td> <td>1</td> </tr> </tbody> </table> <p>D = (Long + Short) / 2 * : Disregard</p>	Zone Dimension	Acceptable number		Class Of Defects	AQL Level	A	B	D < 0.15	*	*	Minor	2.5	0.15 ≤ D < 0.2	4	4	0.2 ≤ D ≤ 0.25	2	2	D ≤ 0.3	0	1							
Zone Dimension	Acceptable number			Class Of Defects	AQL Level																									
	A	B																												
D < 0.15	*	*	Minor	2.5																										
0.15 ≤ D < 0.2	4	4																												
0.2 ≤ D ≤ 0.25	2	2																												
D ≤ 0.3	0	1																												
2	Scratch, Substances	<table border="1"> <thead> <tr> <th colspan="2">Zone</th> <th colspan="2">Acceptable number</th> <th rowspan="2">Class Of Defects</th> <th rowspan="2">AQL Level</th> </tr> <tr> <th>X (mm)</th> <th>Y(mm)</th> <th>A</th> <th>B</th> </tr> </thead> <tbody> <tr> <td>*</td> <td>0.04 ≥ W</td> <td>*</td> <td>*</td> <td rowspan="4">Minor</td> <td rowspan="4">2.5</td> </tr> <tr> <td>3.0 ≥ L</td> <td>0.06 ≥ W</td> <td>4</td> <td>4</td> </tr> <tr> <td>2.0 ≥ L</td> <td>0.08 ≥ W</td> <td>2</td> <td>3</td> </tr> <tr> <td>—</td> <td>0.1 < W</td> <td>0</td> <td>1</td> </tr> </tbody> </table> <p>X : Length Y : Width * : Disregard</p> <p>Total defects should not exceed 4/module</p>	Zone		Acceptable number		Class Of Defects	AQL Level	X (mm)	Y(mm)	A	B	*	0.04 ≥ W	*	*	Minor	2.5	3.0 ≥ L	0.06 ≥ W	4	4	2.0 ≥ L	0.08 ≥ W	2	3	—	0.1 < W	0	1
Zone		Acceptable number		Class Of Defects	AQL Level																									
X (mm)	Y(mm)	A	B																											
*	0.04 ≥ W	*	*	Minor	2.5																									
3.0 ≥ L	0.06 ≥ W	4	4																											
2.0 ≥ L	0.08 ≥ W	2	3																											
—	0.1 < W	0	1																											
3	Air Bubbles (between glass & polarizer)	<table border="1"> <thead> <tr> <th rowspan="2">Zone Dimension</th> <th colspan="2">Acceptable number</th> <th rowspan="2">Class of Defects</th> <th rowspan="2">AQL Level</th> </tr> <tr> <th>A</th> <th>B</th> </tr> </thead> <tbody> <tr> <td>D ≤ 0.15</td> <td>*</td> <td>*</td> <td rowspan="3">Minor</td> <td rowspan="3">2.5</td> </tr> <tr> <td>0.15 < D ≤ 0.25</td> <td>2</td> <td>*</td> </tr> <tr> <td>0.25 < D</td> <td>0</td> <td>1</td> </tr> </tbody> </table> <p>* : Disregard</p> <p>Total defects shall not excess 3/module.</p>	Zone Dimension	Acceptable number		Class of Defects	AQL Level	A	B	D ≤ 0.15	*	*	Minor	2.5	0.15 < D ≤ 0.25	2	*	0.25 < D	0	1										
Zone Dimension	Acceptable number			Class of Defects	AQL Level																									
	A	B																												
D ≤ 0.15	*	*	Minor	2.5																										
0.15 < D ≤ 0.25	2	*																												
0.25 < D	0	1																												

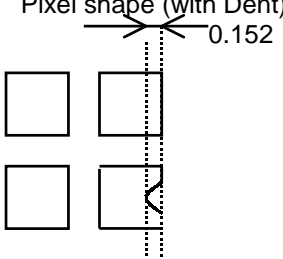
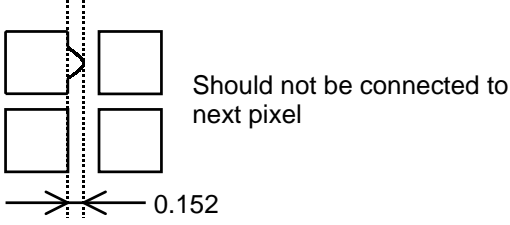
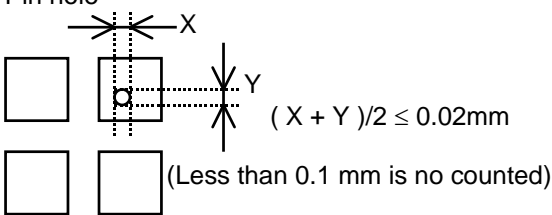
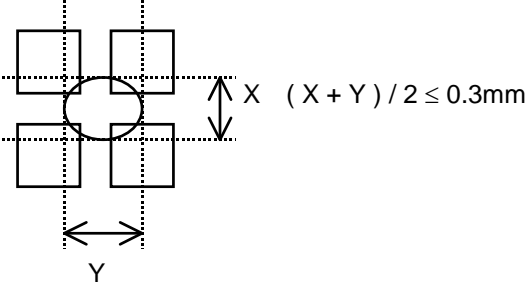
<p>3</p>	<p>Uniformity of Pixel</p>	<p>(1) Pixel shape (with Dent)</p>  <p>(2) Pixel shape (with Projection)</p>  <p>(3) Pin hole</p>  <p>(4) Deformation</p>  <p>Total acceptable number : 1/pixel, 5/cell</p>
----------	----------------------------	--

12. LOT NUMBERING SYSTEM

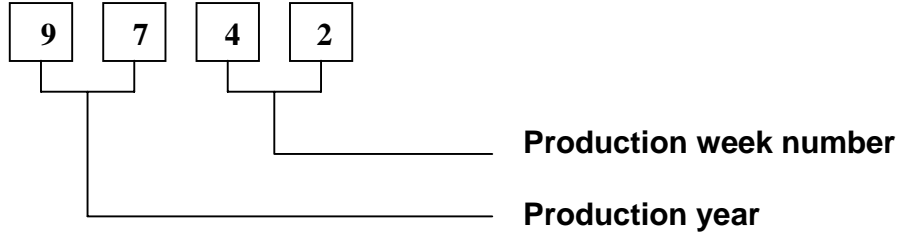

13. LCM NUMBERING SYSTEM

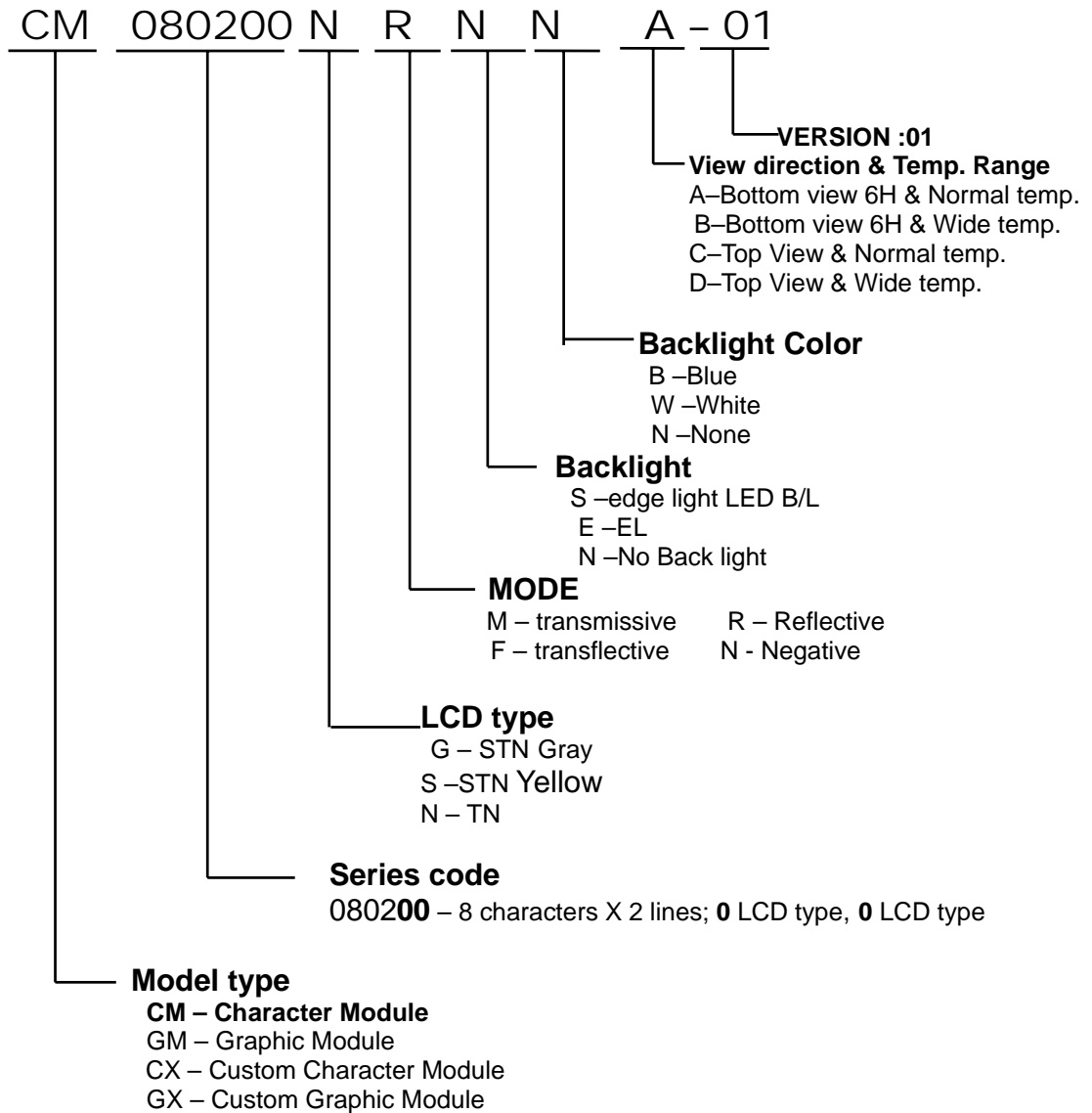

14. PRECAUTION FOR USING LCM

1. LIQUID CRYSTAL DISPLAY (LCD)

LCD is made up of glass, organic sealant, organic fluid, and polymer based polarizers. The following precautions should be taken when handling,

- (1). Keep the temperature within range of use and storage. Excessive temperature and humidity could cause polarization degradation, polarizer peel off or bubble.
- (2). Do not contact the exposed polarizers with anything harder than an HB pencil lead. To clean dust off the display surface, wipe gently with cotton, chamois or other soft material soaked in petroleum benzin.
- (3). Wipe off saliva or water drops immediately. Contact with water over a long period of time may cause polarizer deformation or color fading, while an active LCD with water condensation on its surface will cause corrosion of ITO electrodes.
- (4). Glass can be easily chipped or cracked from rough handling, especially at corners and edges.
- (5). Do not drive LCD with DC voltage.

2. Liquid Crystal Display Modules

2.1 Mechanical Considerations

LCM are assembled and adjusted with a high degree of precision. Avoid excessive shocks and do not make any alterations or modifications. The following should be noted.

- (1). Do not tamper in any way with the tabs on the metal frame.
- (2). Do not modify the PCB by drilling extra holes, changing its outline, moving its components or modifying its pattern.
- (3). Do not touch the elastomer connector, especially insert an backlight panel (for example, EL).
- (4). When mounting a LCM make sure that the PCB is not under any stress such as bending or twisting. Elastomer contacts are very delicate and missing pixels could result from slight dislocation of any of the elements.
- (5). Avoid pressing on the metal bezel, otherwise the elastomer connector could be deformed and lose contact, resulting in missing pixels.

2.2. Static Electricity

LCM contains CMOS LSI's and the same precaution for such devices should apply, namely

- (1). The operator should be grounded whenever he/she comes into contact with the module. Never touch any of the conductive parts such as the LSI pads, the copper leads on the PCB and the interface terminals with any parts of the human body.
- (2). The modules should be kept in antistatic bags or other containers resistant to static for storage.
- (3). Only properly grounded soldering irons should be used.
- (4). If an electric screwdriver is used, it should be well grounded and shielded from commutator sparks.

- (5) The normal static prevention measures should be observed for work clothes and working benches; for the latter conductive (rubber) mat is recommended.
- (6). Since dry air is inductive to statics, a relative humidity of 50-60% is recommended.

2.3 Soldering

- (1). Solder only to the I/O terminals.
- (2). Use only soldering irons with proper grounding and no leakage.
- (3). Soldering temperature : $280^{\circ}\text{C} \pm 10^{\circ}\text{C}$
- (4). Soldering time: 3 to 4 sec.
- (5). Use eutectic solder with resin flux fill.
- (6). If flux is used, the LCD surface should be covered to avoid flux spatters. Flux residue should be removed after wards.

2.4 Operation

- (1). The viewing angle can be adjusted by varying the LCD driving voltage V_0 .
- (2). Driving voltage should be kept within specified range; excess voltage shortens display life.
- (3). Response time increases with decrease in temperature.
- (4). Display may turn black or dark blue at temperatures above its operational range; this is (however not pressing on the viewing area) may cause the segments to appear "fractured".
- (5). Mechanical disturbance during operation (such as pressing on the viewing area) may cause the segments to appear "fractured".

2.5 Storage

If any fluid leaks out of a damaged glass cell, wash off any human part that comes into contact with soap and water. Never swallow the fluid. The toxicity is extremely low but caution should be exercised at all the time.

2.6 Limited Warranty

Unless otherwise agreed between DATA IMAGE and customer, DATA IMAGE will replace or repair any of its LCD and LCM which is found to be defective electrically and visually when inspected in accordance with DATA IMAGE acceptance standards, for a period on one year from date of shipment. Confirmation of such date shall be based on freight documents. The warranty liability of DATA IMAGE is limited to repair and/or replacement on the terms set forth above. DATA IMAGE will not responsible for any subsequent or consequential events.

15. OUTLINE DRAWING

UNITS MM

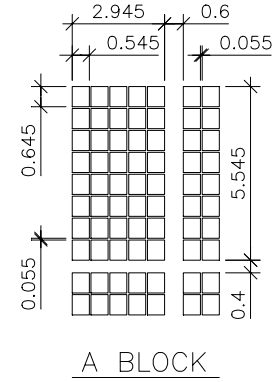
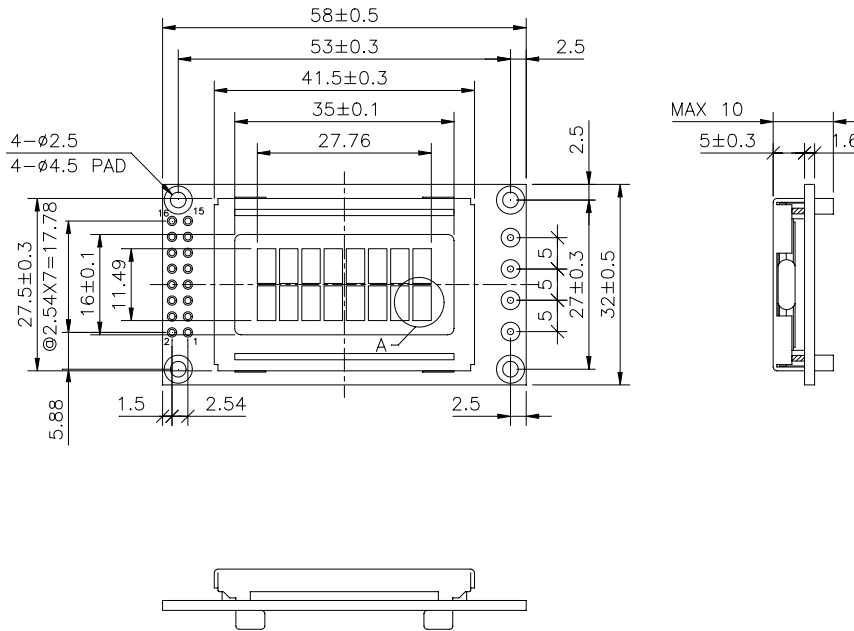

PIN FUNCTIONS

1. VSS	9. DB2
2. VDD	10. DB3
3. VEE	11. DB4
4. RS	12. DB5
5. R/W	13. DB6
6. E	14. DB7
7. DB0	15. LEDA
8. DB1	16. LEDK

16. PACKAGE INFORMATION

