



# DATA IMAGE CORPORATION

## TFT Module Specification

ITEM NO.: FG050720DSSWDGT1

### Table of Contents

1. COVER & CONTENTS .....	1
2. RECORD OF REVISION .....	2
3. APPLICATION.....	3
4. GENERAL SPECIFICATIONS .....	3
5. ABSOLUTE MAXIMUM RATINGS .....	3
6. ELECTRICAL CHARACTERISTICS .....	3
7. BLOCK DIAGRAM .....	4
8. PIN CONNECTIONS .....	5
9. INTERFACE SPECIFICATIONS .....	7
10. OPTICAL CHARACTERISTIC .....	12
11. TOUCH PANEL CHARACTERISTICS .....	15
12. QUALITY ASSURANCE .....	16
13. LOT NUMBERING SYSTEM .....	17
14. LCM NUMBERING SYSTEM .....	17
15. PRECAUTIONS IN USE LCM .....	18
16. OUTLINE DRAWING .....	19
17. PACKAGE INFORMATION .....	20

Customer Companies	R&D Dept.	Q.C. Dept.	Eng. Dept.	Prod. Dept.
	<i>Alex</i>	<i>Eric</i>	<i>Gary</i>	<i>Huang</i>
Approved by	Version:	Issued Date:	Sheet Code:	Total Pages:
	E	2008/2/13		20

**2. RECORD OF REVISION**

Rev	Date	Item	Page	Comment
1	4/JUN/07			Initial preliminary
A	10/SEP/07	4,6,9.2.1 ,10,11, 15	3,6,10,11 ,12,15,18	1. Add Weight. 2. Add Power Supply Current for LCD. 3. Add Power Supply Current for LED. 4. Add LED life time 25000 hours(typ.). 5. Modify Sync mode timing waveform. 6. Add Chromaticity data. 7. Modify T/P data. 8. Change OUTLINE DRAWING.
B	11/OCT/07	3,16	3,19	1.Modify Overall dimension. 2.Change OUTLINE DRAWING from rev:2 to rev:3.
C	29/NOV/07	6,17	3,20	1. Modify LED life time 25000hours to LED Dice life time 50000hours. 2. Change Note1, ambient temperature: from 25 to 22 . 3. Change PACKAGE INFORMATION.
D	18/DEC/07	10	12	Modify Contrast Ratio from 400 min & -- typ. to 200 min & 300 typ.
E	13/FEB/08	11,16	15,19	1. Modify T/P Operating & Storage Temperature data 2. Modify No operation to Non-condensing. 3. Change OUTLINE DRAWING from rev:3 to rev:A.

### 3. APPLICATION

Digital equipments which need color display, such as P.O.S, medical equipments and industrial equipments.

### 4. GENERAL SPECIFICATIONS

Parameter	Specifications	Unit
Display resolution	(640X R.G.B) (W) x480(H)	dot
Active area	115.2(W) x 86.4(H)	mm
Screen size	5.7(Diagonal)	inch
Dot pitch	0.06(W) x 0.18(H)	mm
Color configuration	R.G.B. Stripe	
Overall dimension	127 (W) x 98.43(H) x 9.6(D)	mm
Weight	128	g
Surface treatment	Anti-glare	
View Angle direction	12 o'clock	
Our components and processes are compliant to RoHS standard		

### 5. ABSOLUTE MAXIMUM RATINGS

Parameter	Symbol	MIN.	MAX.	Unit	Remark
Power supply voltage	V <sub>CC</sub>	-0.3	5.0	V	
Logic input voltage	V <sub>I</sub>	-0.3	V <sub>CC</sub> +0.3	V	
Operating temperature	T <sub>OP</sub>	-20	+70	°C	Ambient temperature
Storage temperature	T <sub>ST</sub>	-30	+80	°C	Ambient temperature

### 6. ELECTRICAL CHARACTERISTICS

V<sub>SS</sub>=0V, DCLK=25MHz, T<sub>a</sub>=25°C

Parameter	Symbol	MIN.	Typ.	MAX.	Unit	Remark
Power Supply voltage for LCD	V <sub>CC</sub>	+3.0	+3.3	+3.6	V	
Power Supply Current for LCD	I <sub>CC</sub>		111	140	mA	V <sub>CC</sub> =3.3V
Power Supply voltage for LED	V <sub>LED</sub>	4.5	5	5.5	V	
Power Supply Current for LED	I <sub>LED</sub>		333	400	mA	V <sub>LED</sub> =5.0V
Ripple voltage	V <sub>RF</sub>	-	-	100	mV <sub>P-P</sub>	
"H" level logical input voltage	V <sub>IH</sub>	0.7V <sub>CC</sub>	--	V <sub>CC</sub>	V	
"L" level logical input voltage	V <sub>IL</sub>	0	--	0.3V <sub>CC</sub>	V	
ADJ frequency		19K	20K	21K	Hz	
ADJ input voltage	V <sub>IH</sub>	3.0	-	3.3	V	
	V <sub>IL</sub>	0	-	0.3	V	
LED Dice life time		--	50000	-	Hr	Note 1

Note 1: The "LED dice life time" is defined as the brightness decrease to 50% original brightness that the ambient temperature is 22 °C and LED dice current=20mA.

**7. BLOCK DIAGRAM**

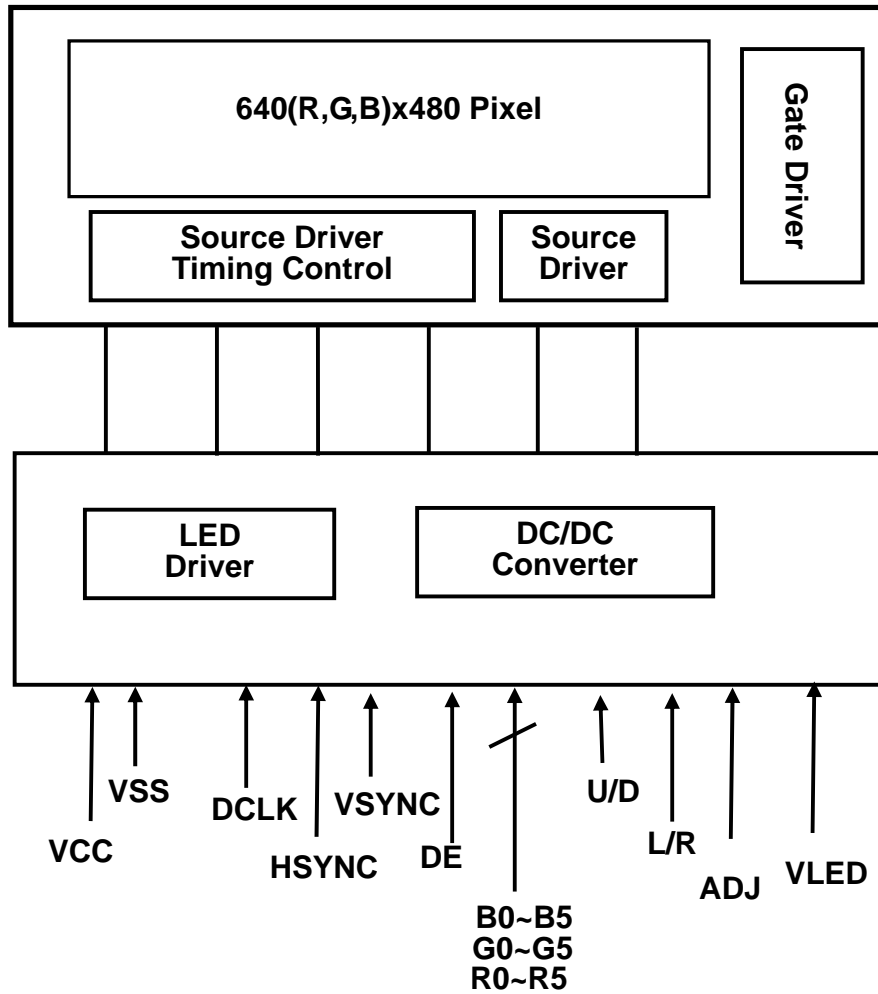

## 8. PIN CONNECTIONS

Pin NO.	SYMBOL	DESCRIPTION
1	U/D	Up or Down Display Control
2	NC	No Connection
3	Hsync	Horizontal SYNC.
4	VLED	Power Supply for LED Driver circuit
5	VLED	Power Supply for LED Driver circuit
6	VLED	Power Supply for LED Driver circuit
7	V <sub>CC</sub>	Power Supply for LCD
8	Vsync	Vertical SYNC.
9	DE	Data Enable
10	X2	Touch Panel control (Left)
11	Y1	Touch Panel control (Up)
12	ADJ	Brightness control for LED B/L
13	B5	Blue Data 5 (MSB)
14	B4	Blue Data 4
15	B3	Blue Data 3
16	V <sub>SS</sub>	Power Ground
17	B2	Blue Data 2
18	B1	Blue Data 1
19	B0	Blue Data 0 (LSB)
20	V <sub>SS</sub>	Power Ground
21	G5	Green Data 5 (MSB)
22	G4	Green Data 4
23	G3	Green Data 3
24	V <sub>SS</sub>	Power Ground
25	G2	Green Data 2
26	G1	Green Data 1
27	G0	Green Data 0 (LSB)
28	V <sub>SS</sub>	Power Ground
29	R5	Red Data 5 (MSB)
30	R4	Red Data 4
31	R3	Red Data 3
32	V <sub>SS</sub>	Power Ground
33	R2	Red Data 2
34	R1	Red Data 1
35	R0	Red Data 0
36	X1	Touch Panel control (Right)
37	Y2	Touch Panel control (Down)
38	DCLK	Clock Signals ; Latch Data at the Falling Edge
39	V <sub>SS</sub>	Power Ground
40	L/R	Left or Right Display Control

Remarks :

- 1) ADJ is brightness control Pin. The larger of the pulse duty is, the higher of the brightness.
- 2) ADJ signal is 0~3.3V. Operation frequency is 20KHz
- 3) VSS PIN must be grounding, can not be floating.

## 4) U/D and L/R control Function

L/R	U/D	Function
1	0	Normally display
0	0	Left and Right opposite
1	1	Up and Down opposite
0	1	Left and Right opposite , Up and Down opposite

5) If DE signal is fixed low, SYNC mode is used. Otherwise, DE mode is used.

**8.1 Power Signal Sequence**

Remarks:

\*1) Power Signal sequence:

$t1 \leq 10\text{ms}$  :  $1 \text{ sec} \leq t5$

$50\text{ms} \leq t2$  :  $200\text{ms} \leq t6$

$0 < t3 \leq 50\text{ms}$  :  $200\text{ms} \leq t7$

$0 < t4 \leq 10\text{ms}$

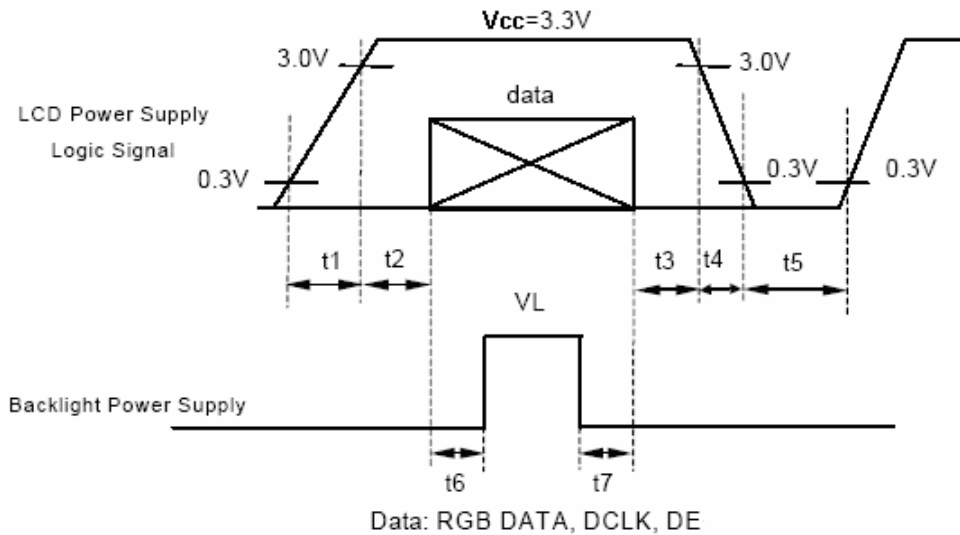

VCC-dip condition:

(1)  $2.7 \text{ V} \leq VCC < 3.0\text{V}$ ,  $t_d \leq 10 \text{ ms}$

(2)  $VCC > 3.0\text{V}$ , VCC-dip condition should be the same with VCC-turn-on condition.

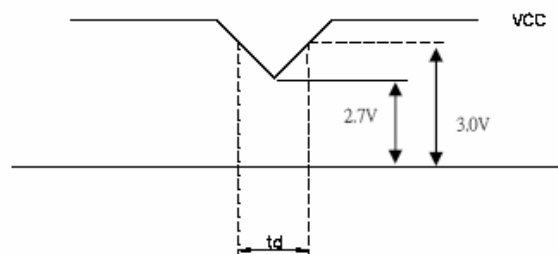

## 9. INTERFACE SPECIFICATIONS

### 9.1 DE mode Input signal characteristics

Signal	Parameter	Symbol	MIN.	TYP.	MAX.	Unit	Remarks
DCLK	Period	$t_{CLK}$	33	40	43	ns	
	Frequency	$f_{CLK}$	23	25	30	MHz	
	Low Level Width	$t_{WCL}$	6	-	-	ns	
	High Level Width	$t_{WCH}$	6	-	-	ns	
	Rise, Fall Time	$t_{CLKr}, t_{CLKf}$	-	-	3	ns	
	Duty	-	0.45	0.50	0.55	-	
DE (Data Enable)	Setup Time	$t_{DES}$	5	-	-	ns	
	Hold Time	$t_{DEH}$	10	-	-	ns	
	Rise, Fall Time	$t_{DEr}, t_{DEf}$	-	-	16	ns	
	Horizontal Period	$t_{HP}$	750	800	900	$t_{CLK}$	
	Horizontal Valid	$t_{HV}$	640	640	640	$t_{CLK}$	
	Horizontal Blank	$t_{HBK}$	110	160	260	$t_{CLK}$	
	Vertical Period	$t_{VP}$	515	525	560	$t_{HP}$	
	Vertical Valid	$t_{VW}$	480	480	480	$t_{HP}$	
	Vertical Blank	$t_{VBK}$	35	45	80	$t_{HP}$	
	Vertical Frequency	$f_v$	55	60	65	Hz	
Data R,G,B	Setup Time	$t_{DS}$	5	-	-	ns	
	Hold Time	$t_{DH}$	10	-	-	ns	
	Rise, Fall Time	$t_{Dr}, t_{Df}$	-	-	3	ns	

Note: (1)  $t_{CLKL} / t_{CLK}$ .

9.1.1 DE mode timing waveform

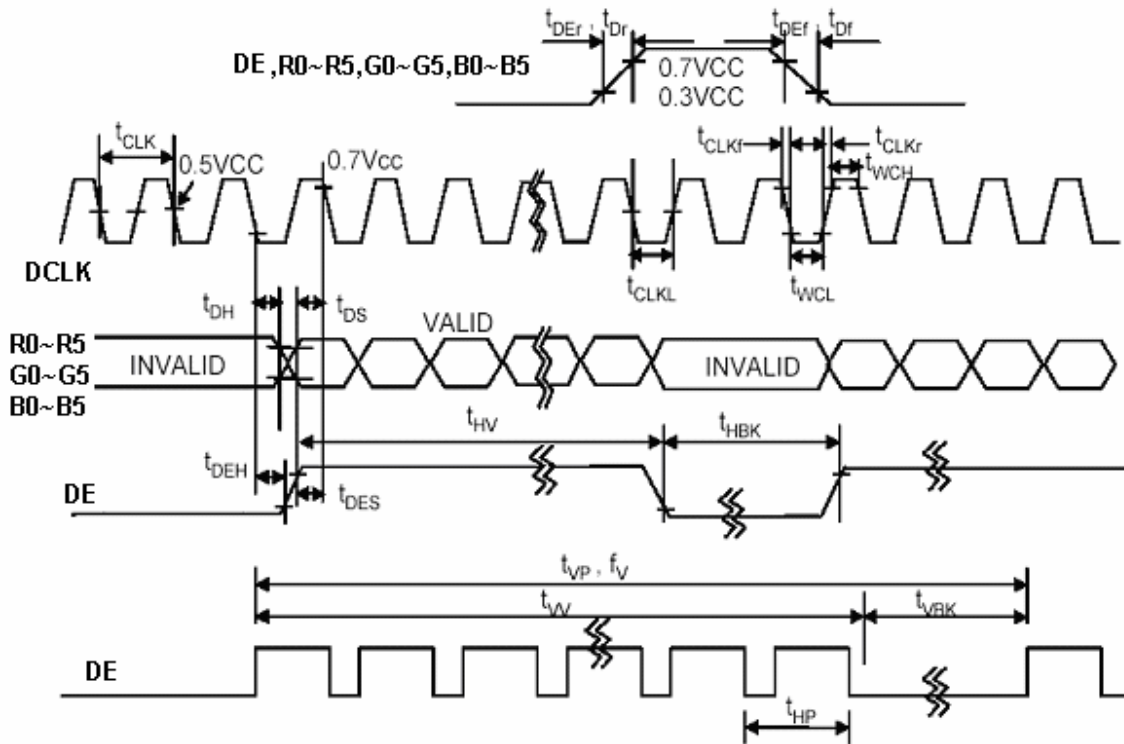



## 9.2 SYNC mode Input signal characteristics

Parameter	Symbol	MIN.	TYP.	MAX.	Unit	Remarks
Clock Period	$t_{CLK}$	33	40	43	ns	
Clock Frequency	$f_{CLK}$	23	25	30	MHz	
Clock Low Level Width	$t_{WCL}$	6	-	-	ns	
Clock High Level Width	$t_{WCH}$	6	-	-	ns	
Clock Rise, Fall Time	$t_{CLKr}, t_{CLKf}$	-	-	3	ns	
HSYNC Period	$t_{HP}$	750	800	900	$t_{CLK}$	
HSYNC Pulse Width	$t_{HW}$	5	30	-	$t_{CLK}$	
HSYNC Front Porch	$t_{HFP}$	1	16	116	$t_{CLK}$	
HSYNC Back Porch	$t_{HBP}$	1	114	139	$t_{CLK}$	
HSYNC Width + Back Porch	$t_{HW} + t_{HBP}$	144	144	144	$t_{CLK}$	
Horizontal Blank	$t_{HBK}$	1	160	260	$t_{CLK}$	
Horizontal Valid	$t_{HV}$	640	640	640	$t_{CLK}$	
VSYNC Period	$t_{VP}$	515	525	560	$t_{HP}$	
VSYNC Pulse Width	$t_{VW}$	1	3	5	$t_{HP}$	
VSYNC Front Porch	$t_{VFP}$	1	10	45	$t_{HP}$	
VSYNC Back Porch	$t_{VBP}$	30	32	34	$t_{HP}$	
VSYNC Width + Back Porch	$t_{VW} + t_{VBP}$	35	35	35	$t_{CLK}$	
Vertical Blank	$t_{VBK}$	35	45	80	$t_{HP}$	
Valid data Width	$t_W$	480	480	480	$t_{HP}$	
Data Setup Time	$t_{DS}$	5	-	-	ns	
Data Hold Time	$t_{DH}$	10	-	-	ns	

Note: (1)  $t_{HBK} = t_{HFP} + t_{HW} + t_{HBP}$

## 9.2.1 SYNC mode timing waveform

### 9.2.1.1 Input vertical timing

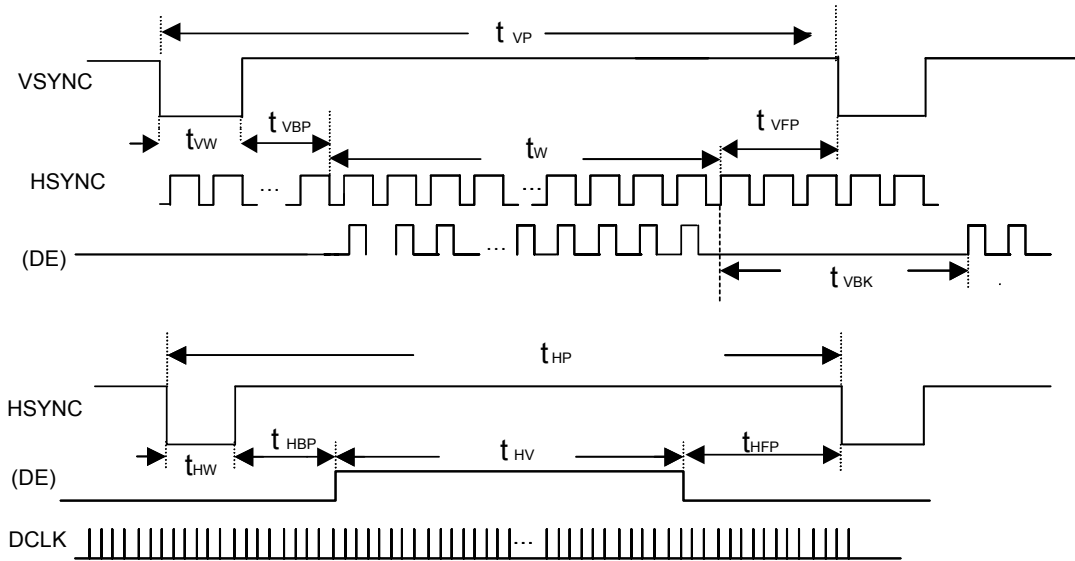

Remark : If SYNC mode is used, please fix DE signal to low, DE timing waveform is for reference only.

### 9.2.1.2 Input horizontal timing

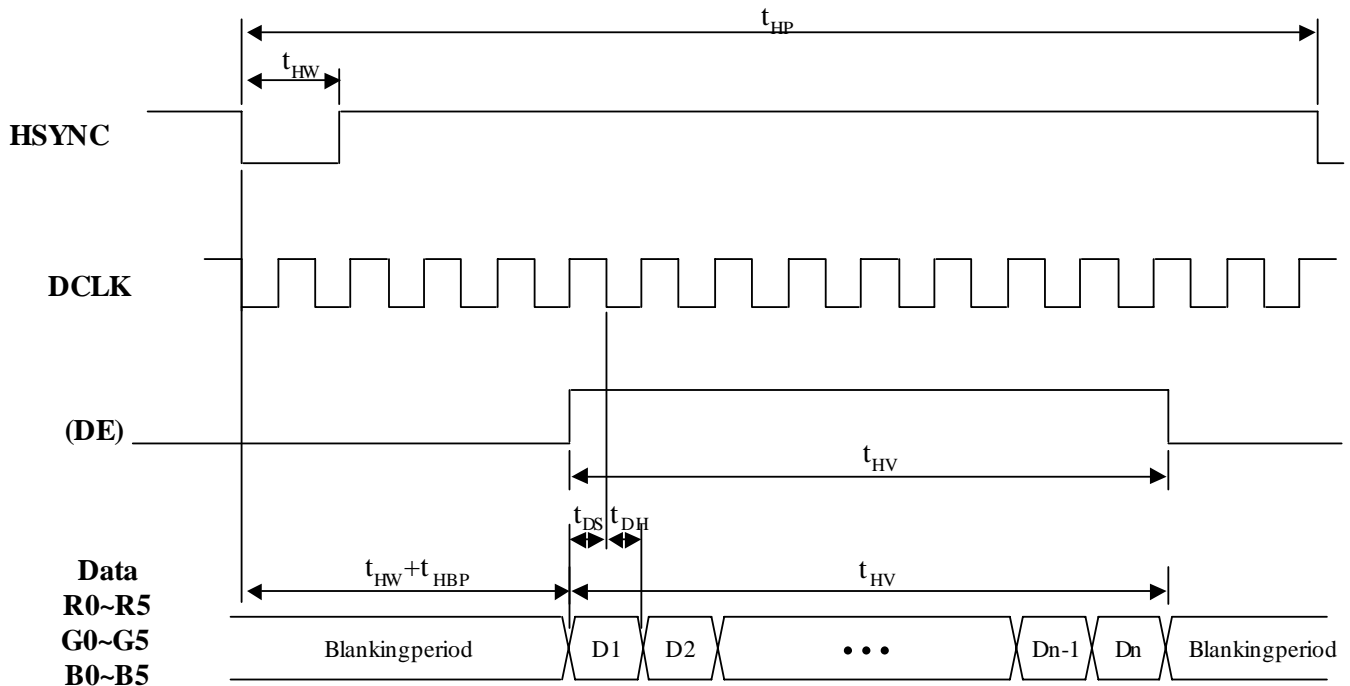

Remark : If SYNC mode is used, please fix DE signal to low, DE timing waveform is for reference only.

**9.3 Color Data Assignment**

COLOR	INPUT	R DATA						G DATA						B DATA					
	DATA	R5	R4	R3	R2	R1	R0	G5	G4	G3	G2	G1	G0	B5	B4	B3	B2	B1	B0
		MSB					LSB	MSB					LSB	MSB					LSB
BASIC COLOR	BLACK	0	0	0	0	0	0	0	0	0	0	0	0	0	0	0	0	0	0
	RED(63)	1	1	1	1	1	1	0	0	0	0	0	0	0	0	0	0	0	0
	GREEN(63)	0	0	0	0	0	0	1	1	1	1	1	1	0	0	0	0	0	0
	BLUE(63)	0	0	0	0	0	0	0	0	0	0	0	0	1	1	1	1	1	1
	CYAN	0	0	0	0	0	0	1	1	1	1	1	1	1	1	1	1	1	1
	MAGENTA	1	1	1	1	1	1	0	0	0	0	0	0	1	1	1	1	1	1
	YELLOW	1	1	1	1	1	1	1	1	1	1	1	1	0	0	0	0	0	0
	WHITE	1	1	1	1	1	1	1	1	1	1	1	1	1	1	1	1	1	1
RED	RED(0)	0	0	0	0	0	0	0	0	0	0	0	0	0	0	0	0	0	0
	RED(1)	0	0	0	0	0	1	0	0	0	0	0	0	0	0	0	0	0	0
	RED(2)	0	0	0	0	1	0	0	0	0	0	0	0	0	0	0	0	0	0
	:	:	:	:	:	:	:	:	:	:	:	:	:	:	:	:	:	:	:
	:	:	:	:	:	:	:	:	:	:	:	:	:	:	:	:	:	:	:
	RED(62)	1	1	1	1	1	0	0	0	0	0	0	0	0	0	0	0	0	0
	RED(63)	1	1	1	1	1	1	0	0	0	0	0	0	0	0	0	0	0	0
GREEN	GREEN(0)	0	0	0	0	0	0	0	0	0	0	0	0	0	0	0	0	0	0
	GREEN(1)	0	0	0	0	0	0	0	0	0	0	0	1	0	0	0	0	0	0
	GREEN(2)	0	0	0	0	0	0	0	0	0	0	1	0	0	0	0	0	0	0
	:	:	:	:	:	:	:	:	:	:	:	:	:	:	:	:	:	:	:
	:	:	:	:	:	:	:	:	:	:	:	:	:	:	:	:	:	:	:
	GREEN(62)	0	0	0	0	0	0	1	1	1	1	1	0	0	0	0	0	0	0
	GREEN(63)	0	0	0	0	0	0	1	1	1	1	1	1	0	0	0	0	0	0
BLUE	BLUE(0)	0	0	0	0	0	0	0	0	0	0	0	0	0	0	0	0	0	0
	BLUE(1)	0	0	0	0	0	0	0	0	0	0	0	0	0	0	0	0	0	1
	BLUE(2)	0	0	0	0	0	0	0	0	0	0	0	0	0	0	0	0	1	0
	:	:	:	:	:	:	:	:	:	:	:	:	:	:	:	:	:	:	:
	:	:	:	:	:	:	:	:	:	:	:	:	:	:	:	:	:	:	:
	BLUE(62)	0	0	0	0	0	0	0	0	0	0	0	0	1	1	1	1	1	0
	BLUE(63)	0	0	0	0	0	0	0	0	0	0	0	0	1	1	1	1	1	1

Remarks:(1) Definition of Gray Scale  
 color(n):n is series of Gray Scale  
 The more n value is, the bright Gray Scale.  
 (2)Data:1-High,0-Low

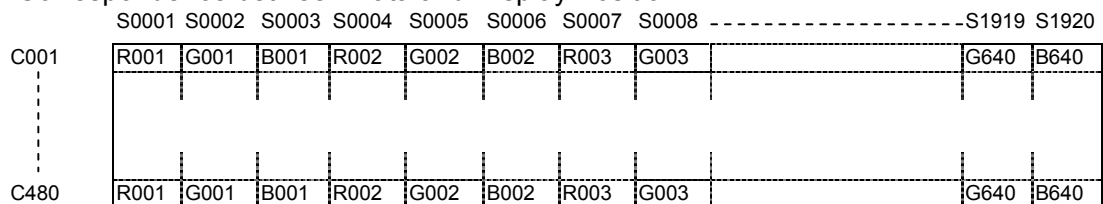
**Correspondence between Data and Display Position**

## 10. Optical Characteristics

### 10-1. Specification:

Parameter	Symbol	Condition	MIN.	TYP.	MAX.	Unit	Remarks	
Viewing Angle	Horizontal	$\theta_{x+}$	60	70	--	deg	Note 1,4	
		$\theta_{x-}$	60	70	--			
	Vertical	$\theta_{y+}$	Center CR $\geq$ 10	50	60			--
		$\theta_{y-}$		30	40			--
Contrast Ratio	CR	at optimized viewing angle	200	300			Note 1,3	
Response time	Rise	Tr	-	15		ms	Note 1,6	
	Fall	Tf	-	35		ms		
Uniformity		B-uni	$\theta_{x=\theta_{y=0^{\circ}}}$	70	80	--	%	Note1,5
Brightness	With T/P	L	$\theta_{x=\theta_{y=0^{\circ}}}$ ADJ=3.3V	250	320	--	cd/m <sup>2</sup>	Note 1,2
Chromaticity	$x_W$	Center $\theta_{x=\theta_{y=0^{\circ}}}$	0.265	0.315	0.365		Note 1,7	
	$y_W$		0.281	0.331	0.381			
	$x_R$		0.555	0.605	0.655			
	$y_R$		0.312	0.362	0.412			
	$x_G$		0.292	0.342	0.392			
	$y_G$		0.487	0.537	0.587			
	$x_B$		0.098	0.148	0.198			
	$y_B$		0.063	0.113	0.163			
Image sticking	tis	2 hours			2	Sec	Note 8	

The following optical specifications shall be measured in a darkroom or equivalent state (ambient luminance  $\leq 1$  lux, and at room temperature). The operation temperature is  $25^{\circ}\text{C} \pm 2^{\circ}\text{C}$ . The measurement method is shown in Note1.

Note1: The method of optical measurement:

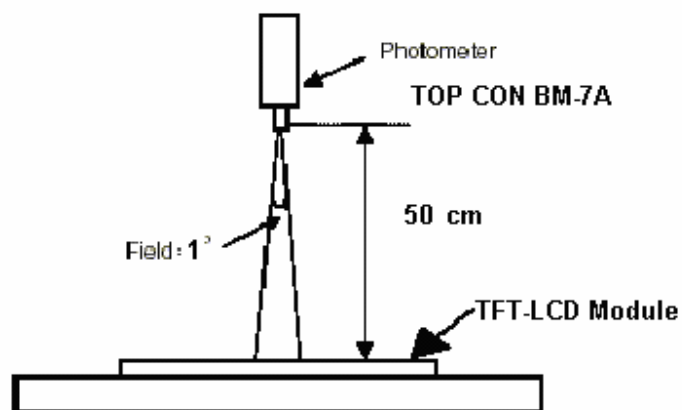

Note2: Measured at the center area of the panel and at the viewing angle of the  $\theta_x = \theta_y = 0^\circ$

Note3: Definition of Contrast Ratio (CR):

$$CR = \frac{\text{Luminance with all pixels in white state}}{\text{Luminance with all pixels in Black state}}$$

Note4: Definition of Viewing Angle

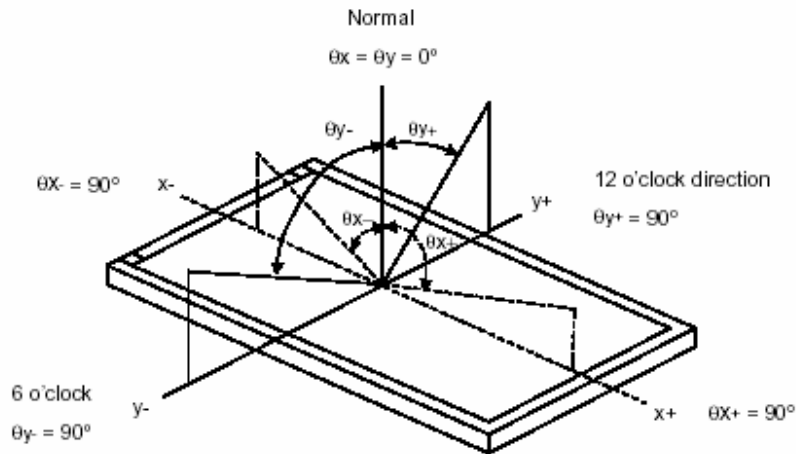

Note 5: Definition of Brightness Uniformity (B-uni):

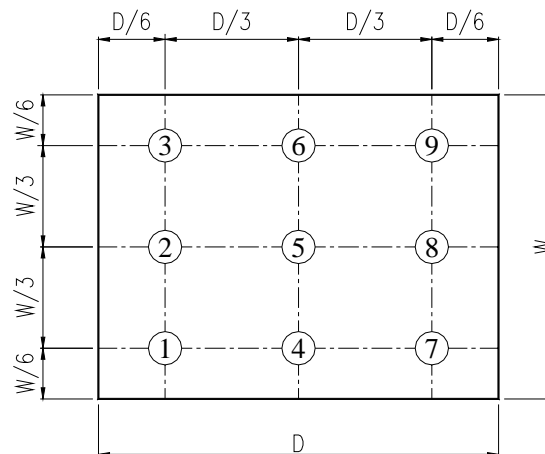

$$B\text{-uni} = \frac{\text{Minimum luminance of 9 points}}{\text{Maximum luminance of 9 points}} \quad (\text{Note 5}).$$

Note6: Definition of Response Time:

The Response Time is set initially by defining the "Rising Time ( $T_r$ )" and the "Falling Time ( $T_f$ )" respectively.  $T_r$  and  $T_f$  are defined as following figure.

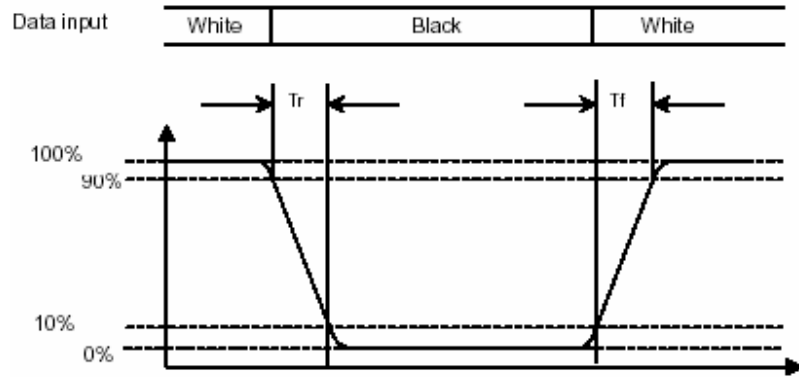

Note 7: Definition of Chromaticity:

The color coordinates  $(x_w, y_w)$ ,  $(x_r, y_r)$ ,  $(x_g, y_g)$ , and  $(x_b, y_b)$  are obtained with all pixels in the viewing field at white, red, green, and blue states, respectively.

Note 8: Definition of Image sticking (tis):

Continuously display the test pattern shown in the figure below for 2 hours. Then display a completely white screen. The previous image shall not persist more than 2 sec at 25 °C

**Image sticking pattern**

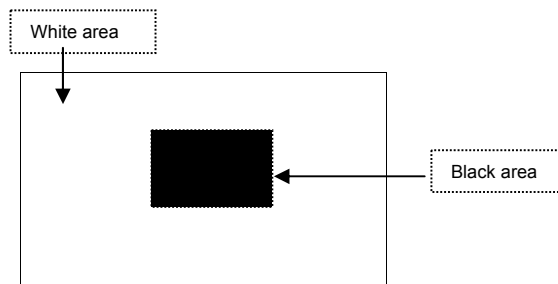

## 11. TOUCH PANEL CHARACTERISTICS

### 1. Input Method and Activation Force

Input Method	Average Activation Force
1.6mm dia. Delrin stylus	≤80gf

### 2. Typical Optical Characteristics

ITEM	Parameter
Visible Light Transmission	>80%
Haze	<10%

### 3. Electrical Specification

ITEM	Parameter
Operating Voltage	DC 5V
Contact current	According to individual design
Circuit close resistance	X 350Ω~970Ω
	Y 80Ω~320Ω
Circuit open resistance	≥20MΩ at DC25V
Contact bounce	≤10ms
Linear Test	≤1.5%

### 4. Linearity

ITEM	Parameter
Linear Test Specification Direction	X ≤1.5%
	Y ≤1.5%

### 5. Specification

ITEM	Parameter	Remarks
Operating Temperature	-20°C~+40°C ,humidity 10~90%RH	Non-condensing.
	+40°C~+70°C ,humidity 10~60%RH	
Storage Temperature	-30°C~+60°C ,humidity 10~90%RH	Non-condensing.
	+60°C~+80°C ,humidity 10~60%RH	

### 6. Durability test:

6.1 Touch panel is hit 1 millions times with a silicone rubber of R8 finger, hitting rate is by 250g. The measurement must satisfy the following:

- Circuit close resistance: x 350Ω~970Ω ;  
y 80Ω~320Ω
- Circuit open resistance: ≥20MΩ at DC25V
- Contact bounce: ≤10ms
- Linearity test: ≤1.5%

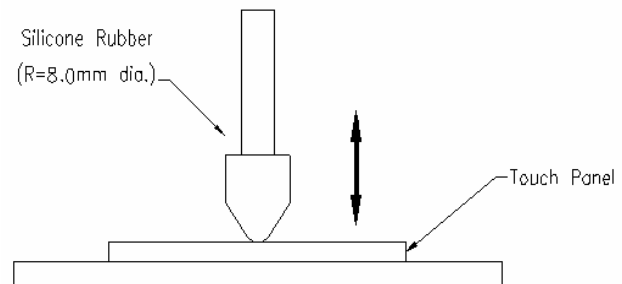

### 6.2 Stylus writing

Touch panel is drawn by R0.8 Delrin stylus pen, at 250g forces, repeat one inch by 100k times. Writing speed: 300 mm / sec. The measurement must satisfy the following:

- Circuit close resistance: x 350Ω~970Ω ;  
y 80Ω~320Ω
- Circuit open resistance: ≥20MΩ at DC25V
- Contact bounce: ≤10ms
- Linearity test: ≤1.5%

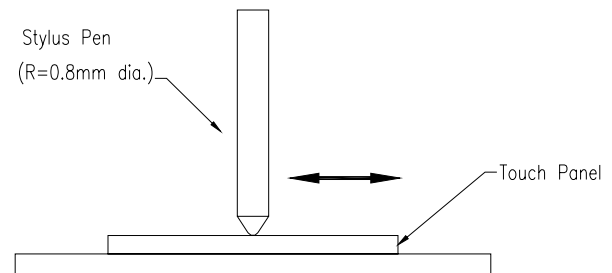

## 12. QUALITY ASSURANCE

### 12.1 Test Condition

#### 12.1.1 Temperature and Humidity(Ambient Temperature)

Temperature :  $25 \pm 5^{\circ}\text{C}$

Humidity :  $65 \pm 5\%$

#### 12.1.2 Operation

Unless specified otherwise, test will be conducted under function state.

#### 12.1.3 Container

Unless specified otherwise, vibration test will be conducted to the product itself without putting it in a container.

#### 12.1.4 Test Frequency

In case of related to deterioration such as shock test. It will be conducted only once.

#### 12.1.5 Test Method

No.	Reliability Test Item & Level	Test Level
1	High Temperature Storage Test	T=80°C,240hrs
2	Low Temperature Storage Test	T=-30°C,240hrs
3	High Temperature Operation Test	T=70°C,240hrs
4	Low Temperature Operation Test	T=-20°C,240hrs
5	High Temperature and High Humidity Operation Test	T=60°C,90% RH,240hrs
6	Thermal Cycling Test (No operation)	-30°C → +25°C → +80°C,200 Cycles 30 min 5min 30 min
7	Vibration Test (No operation)	Frequency:0 ~ 55 Hz Amplitude:1.5 mm Sweep Time:11min Test Period:6 Cycles for each Direction of X,Y,Z
8	Electrostatic Discharge Test (No operation)	150pF,330Ω Air:± 12KV;Contact: ±6KV 10 times/point;4 points/panel face



### 13. LOT NUMBERING SYSTEM

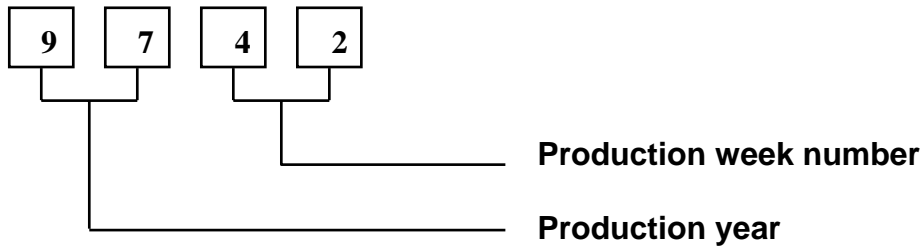

### 14. LCM NUMBERING SYSTEM

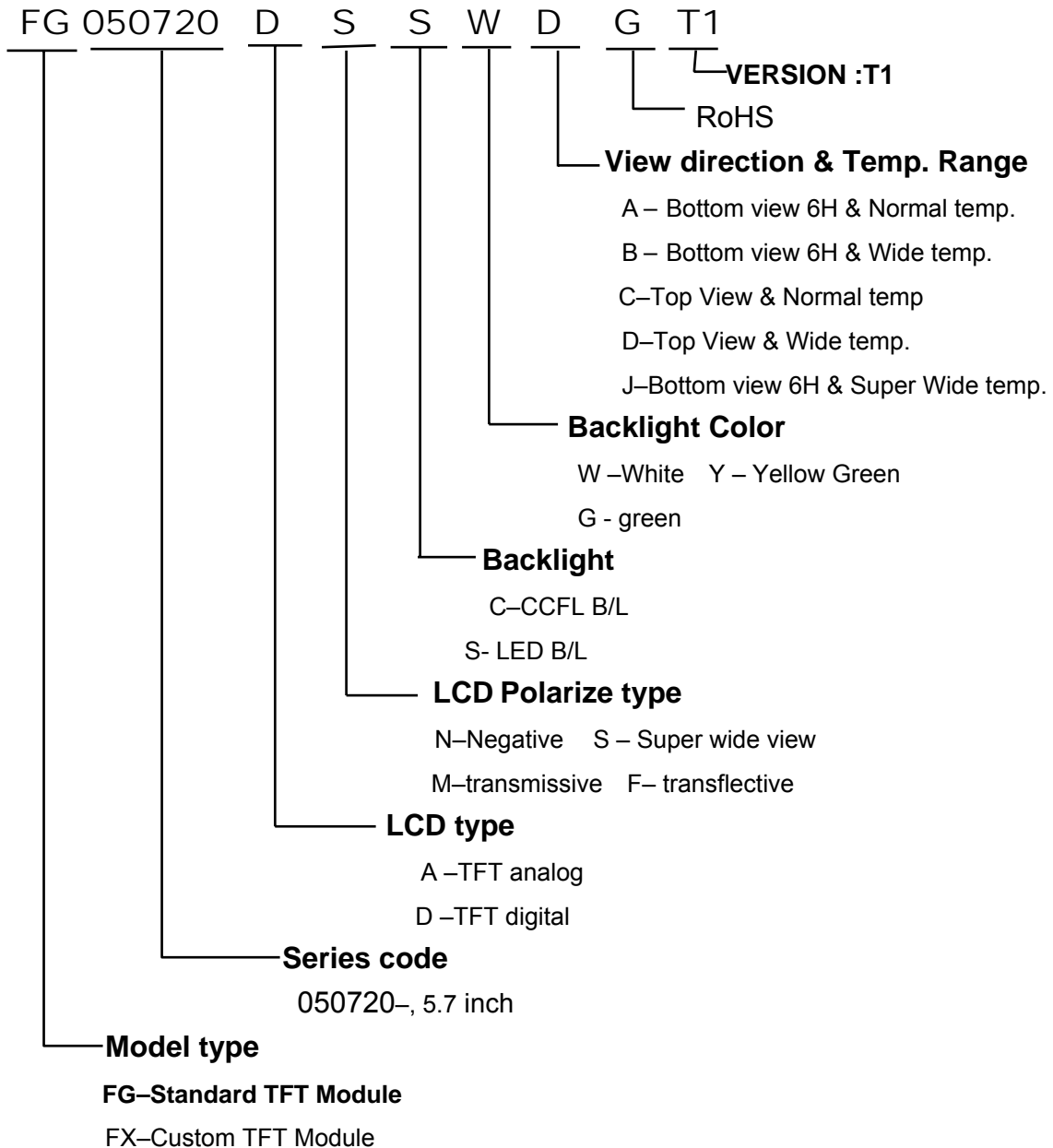

## 15. PRECAUTION IN USE LCM

### 1. LIQUID CRYSTAL DISPLAY (LCD)

LCD is made up of glass, organic sealant, organic fluid, and polymer based polarizers. The following precautions should be taken when handling,

- (1). Keep the temperature within range of use and storage. Excessive temperature and humidity could cause polarization degradation, polarizer peel off or bubble.
- (2). Do not contact the exposed polarizers with anything harder than an HB pencil lead. To clean dust off the display surface, wipe gently with cotton, chamois or other soft material soaked in petroleum benzine.
- (3). Wipe off saliva or water drops immediately. Contact with water over a long period of time may cause polarizer deformation or color fading, while an active LCD with water condensation on its surface will cause corrosion of ITO electrodes.
- (4). Glass can be easily chipped or cracked from rough handling, especially at corners and edges.
- (5). Do not drive LCD with DC voltage.

### 2. Liquid Crystal Display Modules

#### 2.1 Mechanical Considerations

LCM are assembled and adjusted with a high degree of precision. Avoid excessive shocks and do not make any alterations or modifications. The following should be noted.

- (1). Do not tamper in any way with the tabs on the metal frame.
- (2). Do not modify the PCB by drilling extra holes, changing its outline, moving its components or modifying its pattern.
- (3). Do not touch the elastomer connector, especially insert an backlight panel (for example, EL).
- (4). When mounting a LCM make sure that the PCB is not under any stress such as bending or twisting. Elastomer contacts are very delicate and missing pixels could result from slight dislocation of any of the elements.
- (5). Avoid pressing on the metal bezel, otherwise the elastomer connector could be deformed and lose contact, resulting in missing pixels.

#### 2.2. Static Electricity

LCM contains CMOS LSI's and the same precaution for such devices should apply, namely

- (1). The operator should be grounded whenever he/she comes into contact with the module. Never touch any of the conductive parts such as the LSI pads, the copper leads on the PCB and the interface terminals with any parts of the human body.
- (2). The modules should be kept in antistatic bags or other containers resistant to static for storage.
- (3). Only properly grounded soldering irons should be used.
- (4). If an electric screwdriver is used, it should be well grounded and shielded from commutator sparks.

(5) The normal static prevention measures should be observed for work clothes and working benches; for the latter conductive (rubber) mat is recommended.

(6). Since dry air is inductive to statics, a relative humidity of 50-60% is recommended.

#### 2.3 Soldering

- (1). Solder only to the I/O terminals.
- (2). Use only soldering irons with proper grounding and no leakage.
- (3). Soldering temperature :  $280^{\circ}\text{C} \pm 10^{\circ}\text{C}$
- (4). Soldering time: 3 to 4 sec.
- (5). Use eutectic solder with resin flux fill.
- (6). If flux is used, the LCD surface should be covered to avoid flux spatters. Flux residue should be removed afterwards.

#### 2.4 Operation

- (1). The viewing angle can be adjusted by varying the LCD driving voltage  $V_0$ .
- (2). Driving voltage should be kept within specified range; excess voltage shortens display life.
- (3). Response time increases with decrease in temperature.
- (4). Display may turn black or dark blue at temperatures above its operational range; this is (however not pressing on the viewing area) may cause the segments to appear "fractured".
- (5). Mechanical disturbance during operation (such as pressing on the viewing area) may cause the segments to appear "fractured".

#### 2.5 Storage

If any fluid leaks out of a damaged glass cell, wash off any human part that comes into contact with soap and water. Never swallow the fluid. The toxicity is extremely low but caution should be exercised at all the time.

#### 2.6 Limited Warranty

Unless otherwise agreed between DATA IMAGE and customer, DATA IMAGE will replace or repair any of its LCD and LCM which is found to be defective electrically and visually when inspected in accordance with DATA IMAGE acceptance standards, for a period on one year from date of shipment. Confirmation of such date shall be based on freight documents. The warranty liability of DATA IMAGE is limited to repair and/or replacement on the terms set forth above. DATA IMAGE will not responsible for any subsequent or consequential events.

### 16. OUTLINE DRAWING

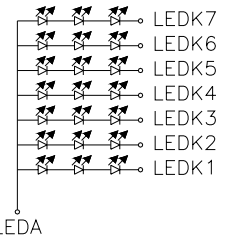
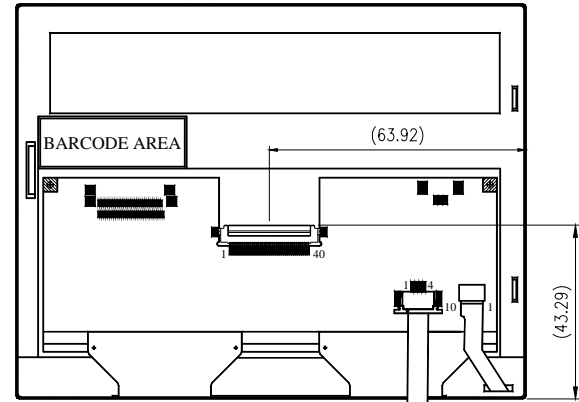
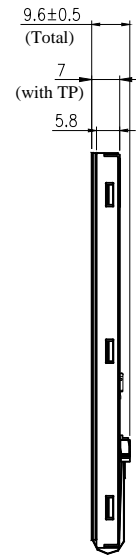
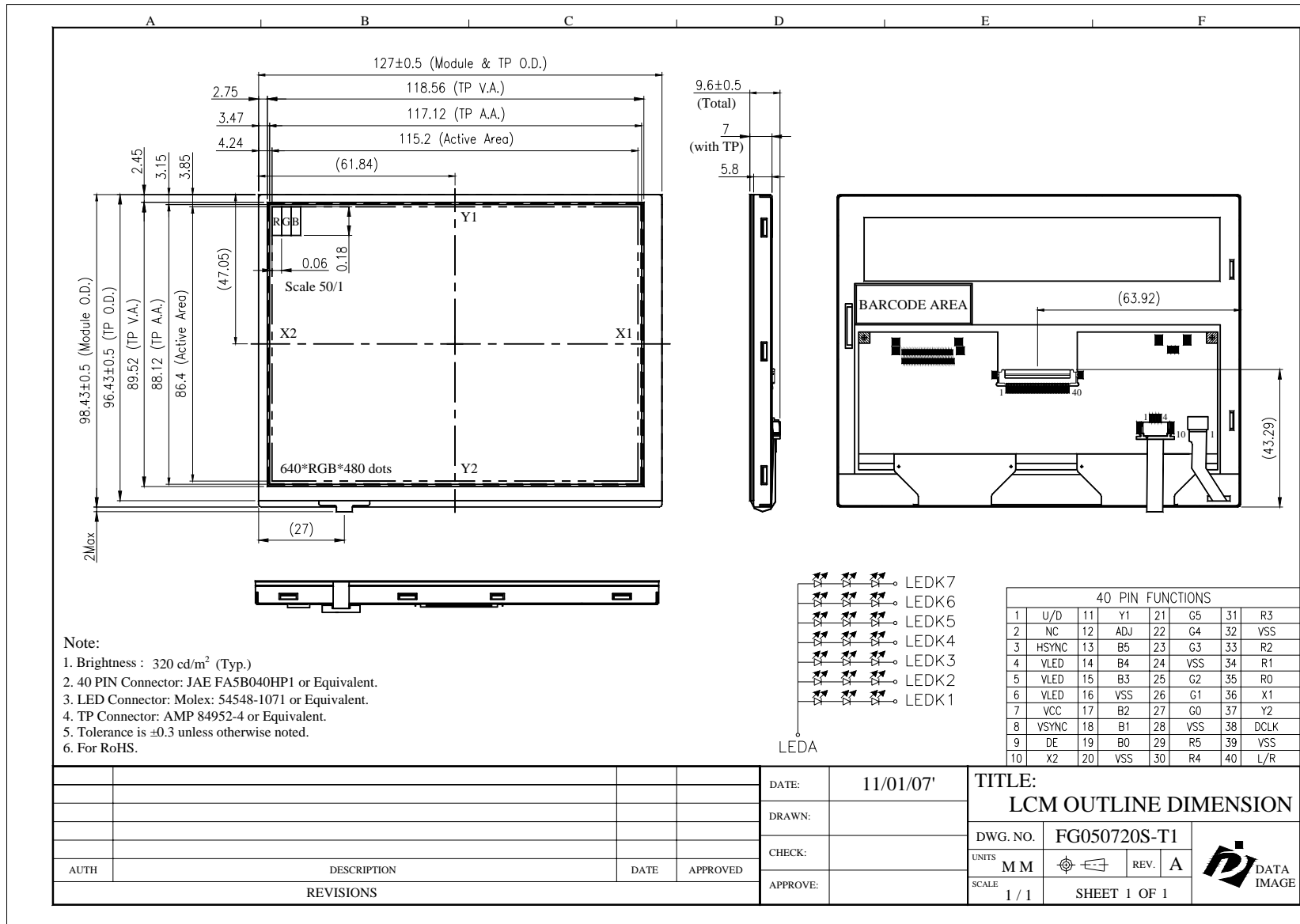

40 PIN FUNCTIONS									
1	U/D	11	Y1	21	G5	31	R3		
2	NC	12	ADJ	22	G4	32	VSS		
3	HSYNC	13	B5	23	G3	33	R2		
4	VLED	14	B4	24	VSS	34	R1		
5	VLED	15	B3	25	G2	35	R0		
6	VLED	16	VSS	26	G1	36	X1		
7	VCC	17	B2	27	G0	37	Y2		
8	VSYNC	18	B1	28	VSS	38	DCLK		
9	DE	19	B0	29	R5	39	VSS		
10	X2	20	VSS	30	R4	40	L/R		

- Note:
- Brightness : 320 cd/m<sup>2</sup> (Typ.)
  - 40 PIN Connector: JAE FA5B040HP1 or Equivalent.
  - LED Connector: Molex: 54548-1071 or Equivalent.
  - TP Connector: AMP 84952-4 or Equivalent.
  - Tolerance is ±0.3 unless otherwise noted.
  - For RoHS.

				DATE:	11/01/07'	TITLE:			
				DRAWN:		LCM OUTLINE DIMENSION			
				CHECK:		DWG. NO.	FG050720S-T1		
				APPROVE:		UNITS	M M	REV.	A
REVISIONS						SCALE	1 / 1		SHEET 1 OF 1

Confidential Document  
**17.PACKAGE INFORMATION**

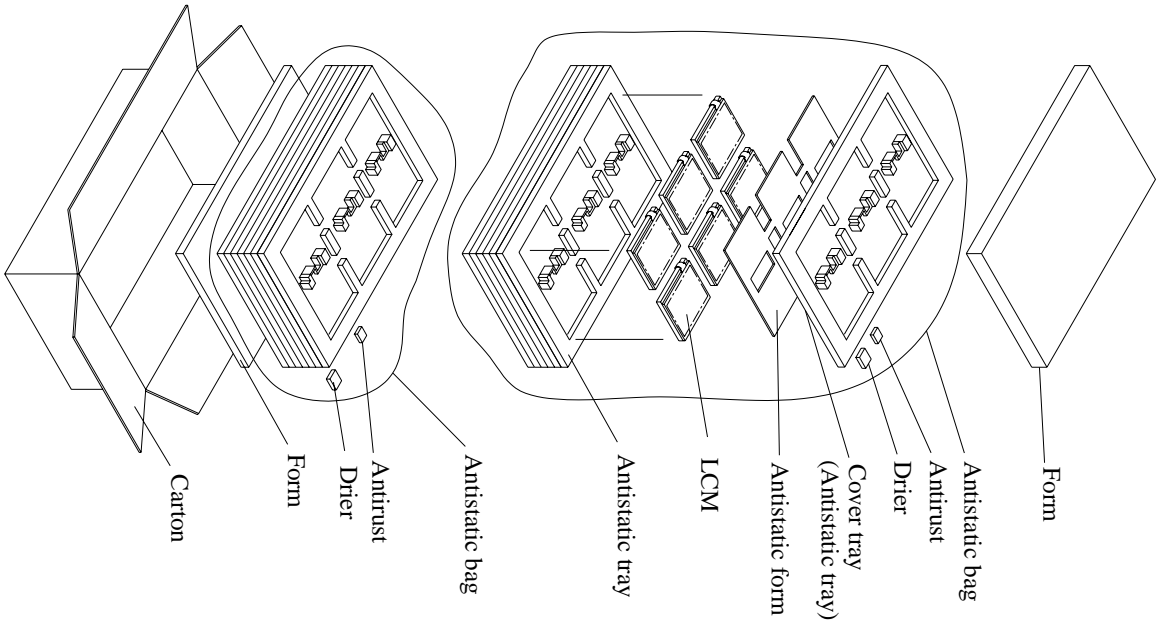

**Material**

1 Carton + 2 Anti-static bag + 1 Form(35mm) + 1 Form(15mm)  
+ 14 Anti-static tray + 2 Drier + 2 Antirust

**Total pcs**

- 1 Antistatic tray = 6 pcs
- 1 Anti-static bag = 6 Anti-static tray + cover tray = 6\*6 + 1\*0 = 36 pcs
- 1 Carton = 2 Anti-static bag = 2\*36 = 72 pcs
- 1 Carton = 72pcs

Carton size : 482L x 282W x 279H (mm)

Total Weight ÷ 12.3 kgw

**FG050720+TP TFT LCM PACKING**