

# DISPLAYTRONIC

*XIAMEN ZETTLER ELECTRONICS CO., LTD*

## SPECIFICATIONS FOR LIQUID CRYSTAL DISPLAY

ACM1602B SERIES CHARACTER MODULE VER1.1

CUSTOMER APPROVAL			
1.POLARIZER OPTIONS: <input type="checkbox"/> R=REFLECTIVE <input type="checkbox"/> F=TRANSFLECTIVE <input type="checkbox"/> N=TRANSMISSIVE NEGATIVE <input type="checkbox"/> M=TRANSMISSIVE POSITIVE			
2.BACKLIGHT OPTIONS: <input type="checkbox"/> N=NONE <input type="checkbox"/> E=EL <input type="checkbox"/> L=LED (Y-G ) <input type="checkbox"/> C=CCFL			
3. BACKLIGHT COLOR: <input type="checkbox"/> A= AMBER <input type="checkbox"/> B= BLUE <input type="checkbox"/> G= GREEN <input type="checkbox"/> W=WHITE <input type="checkbox"/> R= RED <input type="checkbox"/> RGB= RED+GREEN+BLUE			
4.FLUID OPTIONS: <input type="checkbox"/> T=TN <input type="checkbox"/> F=FSTN <input type="checkbox"/> Y=STN-YELLOW GREEN <input type="checkbox"/> G=STN-GRAY <input type="checkbox"/> B=STN-BLUE			
5. VIEWING DIRECTION: <input type="checkbox"/> B=BOTTOM VIEW(6 O'CLOCK) <input type="checkbox"/> T=TOP VIEW(12 O'CLOCK)			
6.TEMPERATURE RANGE: <input type="checkbox"/> S=STANDARD TEMPERATURE RANGE <input type="checkbox"/> H=DUAL POWER,WIDE TEMPERATURE RANGE <input type="checkbox"/> W=SINGLE POWER,WIDE TEMPERATURE RANGE			
7.OTHERS REQUIREMENT:			
※ PART NO. : _____			
APPROVAL		COMPANY CHOP	
CUSTOMER COMMENTS			

DISPLAYTRONIC ENGINEERING APPROVAL		
DESIGN BY	CHECKED BY	APPROVED BY

**REVISION RECORD**

REVISION	REVISION DATE	PAGE	CONTENTS
<b>VER1.1</b>	<b>15/6-2006</b>		<b>MODIFY THE COVER,ADD CONTENT AND REVISION RECORD.</b>

## ※ CONTENTS

- 1.0 MECHANICAL SPECS
- 2.0 ABSOLUTE MAXIMUM RATINGS
- 3.0 ELECTRICAL CHARACTERISTICS
- 4.0 OPTICAL CHARACTERISTICS (TA=25°C, VDD= 5.0V±0.25V, TN LC FLUID)
- 4.1 OPTICAL CHARACTERISTICS (TA=25°C, VDD= 5.0V±0.25V, STN LC FLUID)
- 5.0 BLOCK DIAGRAM
- 6.0 PIN ASSIGNMENT
- 7.0 POWER SUPPLY
- 8.0 TIMING CHARACTERISTICS
- 9.0 MECHANICAL DIAGRAM
- 10.0 RELIABILITY TEST
- 11.0 DISPLAY INSTRUCTION TABLE
- 12.0 STANDARD CHARACTER PATTERNS

# ACM1602B SERIES CHARACTER MODULE VER1.1

## 1.0 MECHANICAL SPECS

1. Overall Module Size	84.0mm(W) x 44.0mm(H) x max 13.5mm(D) for LED backlight version 84.0mm(W) x 44.0mm(H) x max 9.5mm(D) for reflective version
2. Dot Size	0.56mm(W) x 0.61mm(H)
3. Dot Pitch	0.61mm(W) x 0.66mm(H)
4. Duty	1/16
5. Controller IC	SPLC780D or compatible
6. LC Fluid Options	TN, STN
7. Polarizer Options	Reflective, Transflective, Transmissive
8. Backlight Options	LED
9. Temperature Range Options	Standard ( 0°C ~ 50°C),Wide(-20°C ~ 70°C)

## 2.0 ABSOLUTE MAXIMUM RATINGS

Item	Symbol	Min	Typ	Max	Unit
Operating temperature (Standard)	Top	0	-	50	°C
Storage temperature (Standard)	Tst	-10	-	60	°C
Operating temperature (Wide temperature)	Top	-20	-	70	°C
Storage temperature (Wide temperature)	Tst	-30	-	80	°C
Input voltage	Vin	Vss		Vdd	V
Supply voltage for logic	Vdd- Vss	2.7	-	5.5	V
Supply voltage for LCD drive	Vdd- Vo	3.0	4.6	6.5	V

### 3.0 ELECTRICAL CHARACTERISTICS

Item	Symbol	Condition	Min	Typ	Max	Unit
Input voltage (high)	Vih	H level	2.2	-	Vdd	V
Input voltage (low)	Vil	L level	0	-	0.6	V
Recommended LC Driving Voltage (Standard Temp)	Vdd - Vo	0°C	-	4.8	5.4	V
		25°C	4.2	4.6	-	
		50°C	3.9	4.3	-	
Recommended LC Driving Voltage (Wide Temp)	Vdd -Vo	-20°C	-	6.4	7.2	V
		0°C	-	4.8	-	
		50°C	-	4.2	-	
		70°C	3.5	4.0	-	
Power Supply Current	Idd	Vdd=5.0V, fosc=270kHz	-	0.8	1.8	mA
LED Power Supply Voltage	VF	IF=120mA	-	3.9	4.3	V
LED Power Supply Current	IF	5.0V, 6.8Ω	-	120	200	mA

### 4.0 OPTICAL CHARACTERISTICS (Ta=25°C, Vdd= 5.0V±0.25V, TN LC fluid)

Item	Symbol	Condition	Min	Typ	Max	Unit
Viewing angle (horizontal)	θ	Cr ≥ 4.0	-25	-	-	deg
Viewing angle (vertical)	φ	Cr ≥ 4.0	-30	-	30	deg
Contrast Ratio	Cr	φ=0°, θ=0°	-	2	-	
Response time (rise)	Tr	φ=0°, θ=0°	-	120	150	ms
Response time (fall)	Tf	φ=0°, θ=0°	-	120	150	ms

**4.1 OPTICAL CHARACTERISTICS (Ta=25°C, Vdd= 5.0V±0.25V, STN LC fluid)**

Item	Symbol	Condition	Min	Typ	Max	Unit
Viewing angle (horizontal)	$\theta$	$Cr \geq 2.0$	-60	-	35	deg
Viewing angle (vertical)	$\phi$	$Cr \geq 2.0$	-40	-	40	deg
Contrast Ratio	Cr	$\phi=0^\circ, \theta=0^\circ$	-	6	-	
Response time (rise)	Tr	$\phi=0^\circ, \theta=0^\circ$	-	150	250	ms
Response time (fall)	Tf	$\phi=0^\circ, \theta=0^\circ$	-	150	250	ms

**5.0 BLOCK DIAGRAM**

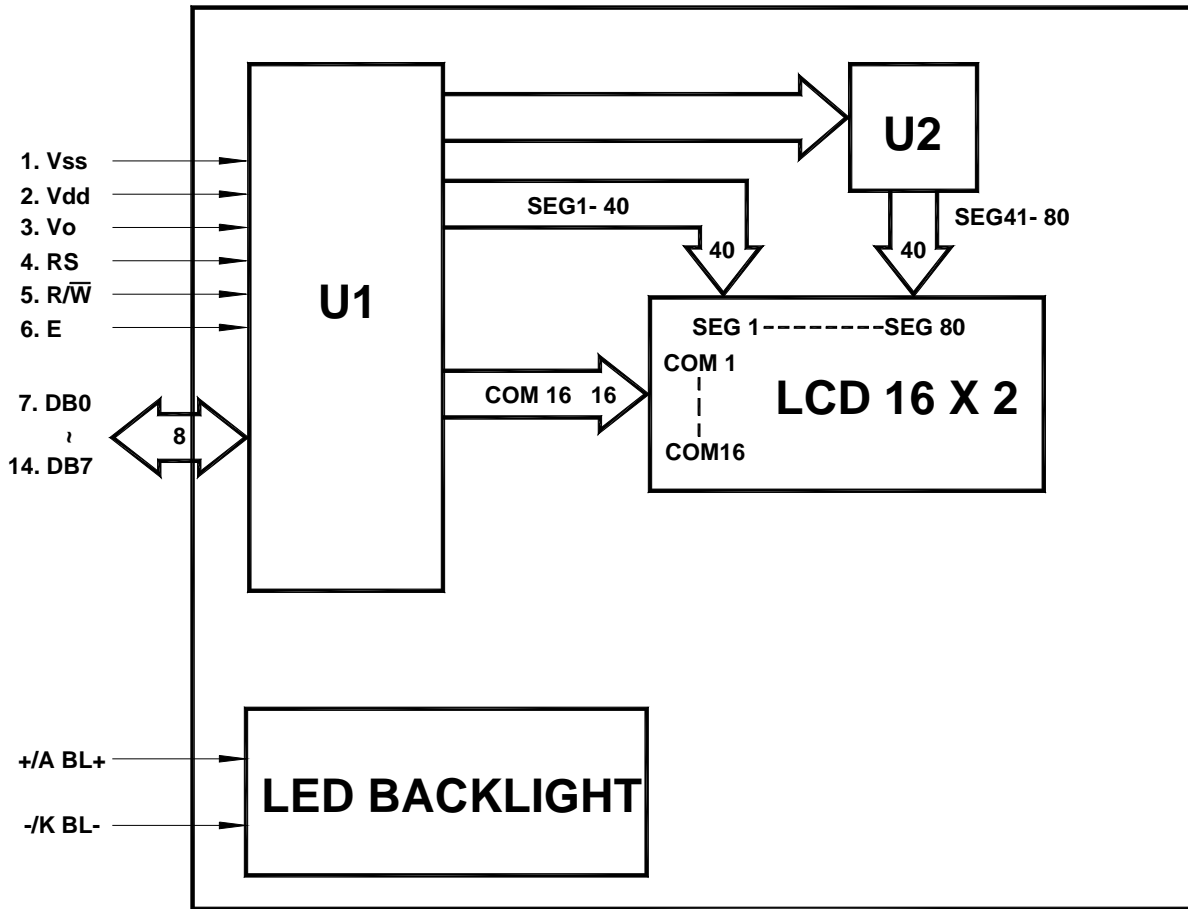

## 6.0 PIN ASSIGNMENT

Pin No.	Symbol	Function
1	Vss	Ground
2	Vdd	+5V
3	Vo	LCD contrast adjust
4	RS	Register select
5	R/W	Read / write
6	E	Enable
7	DB0	Data bit 0
8	DB1	Data bit 1
9	DB2	Data bit 2
10	DB3	Data bit 3
11	DB4	Data bit 4
12	DB5	Data bit 5
13	DB6	Data bit 6
14	DB7	Data bit 7
-	BL-	Power Supply for BL-
+	BL+	Power Supply for BL+

## 7.0 POWER SUPPLY

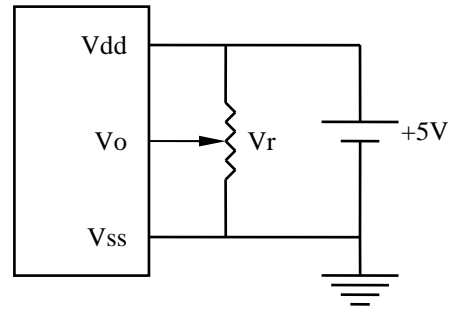

STANDARD TEMP RANGE

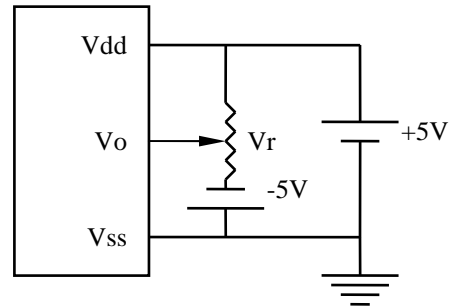

WIDE TEMP RANGE

$V_r = 10K\Omega \sim 20K\Omega$

## 8.0 TIMING CHARACTERISTICS

Item	Symbol	Test Condition	Min.	Typ.	Max.	Unit
Enable cycle time	$t_c$	Fig. a, Fig. b	500	-	-	ns
Enable pulse width	$t_w$	Fig. a, Fig. b	220	-	-	ns
Enable rise/fall time	$t_r, t_f$	Fig. a, Fig. b	-	-	25	ns
RS, R/W set up time	$t_{su}$	Fig. a, Fig. b	40	-	-	ns
RS, R/W hold time	$t_h$	Fig. a, Fig. b	10	-	-	ns
Data delay time	$t_d$	Fig. b	-	-	120	ns
Data set up time	$t_{dsu}$	Fig. a	60	-	-	ns
Data hold time	$t_{dh}$	Fig. a, Fig. b	20	-	-	ns

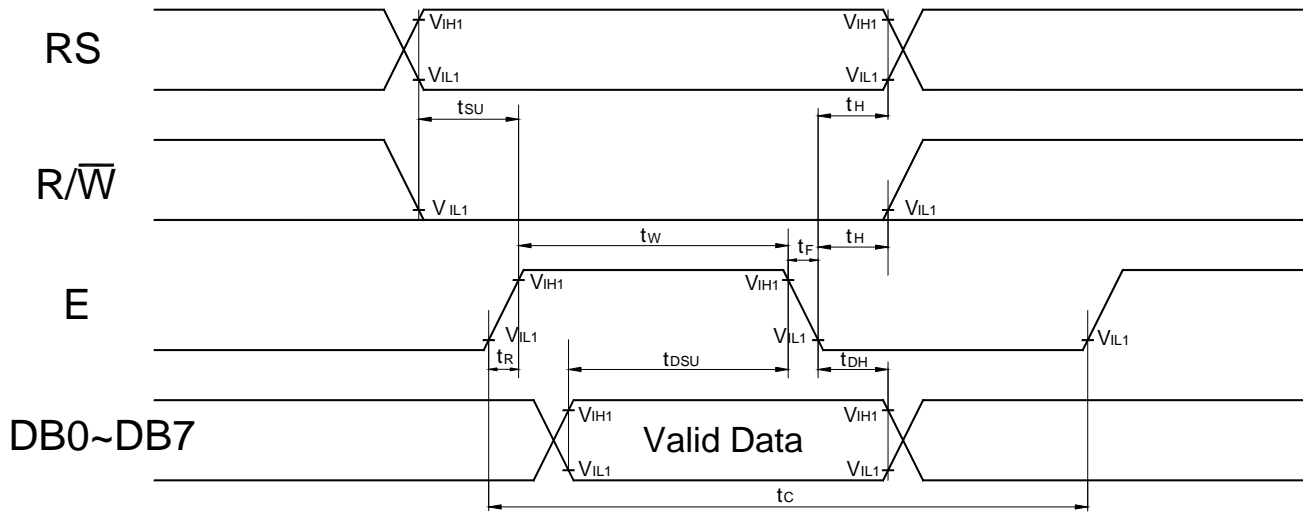

Fig. a Interface timing (data write)

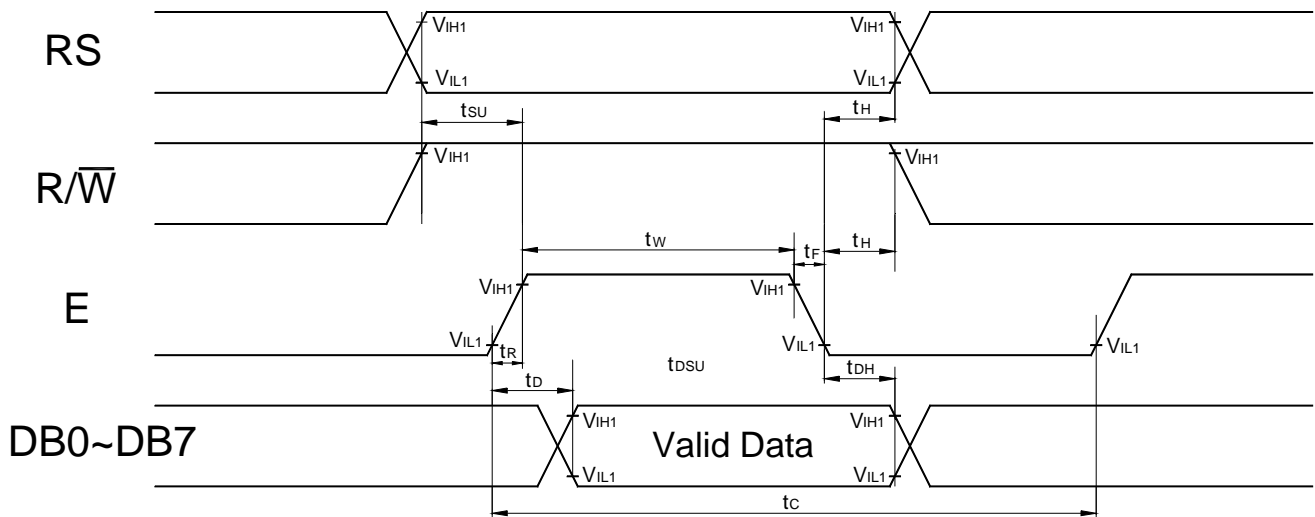
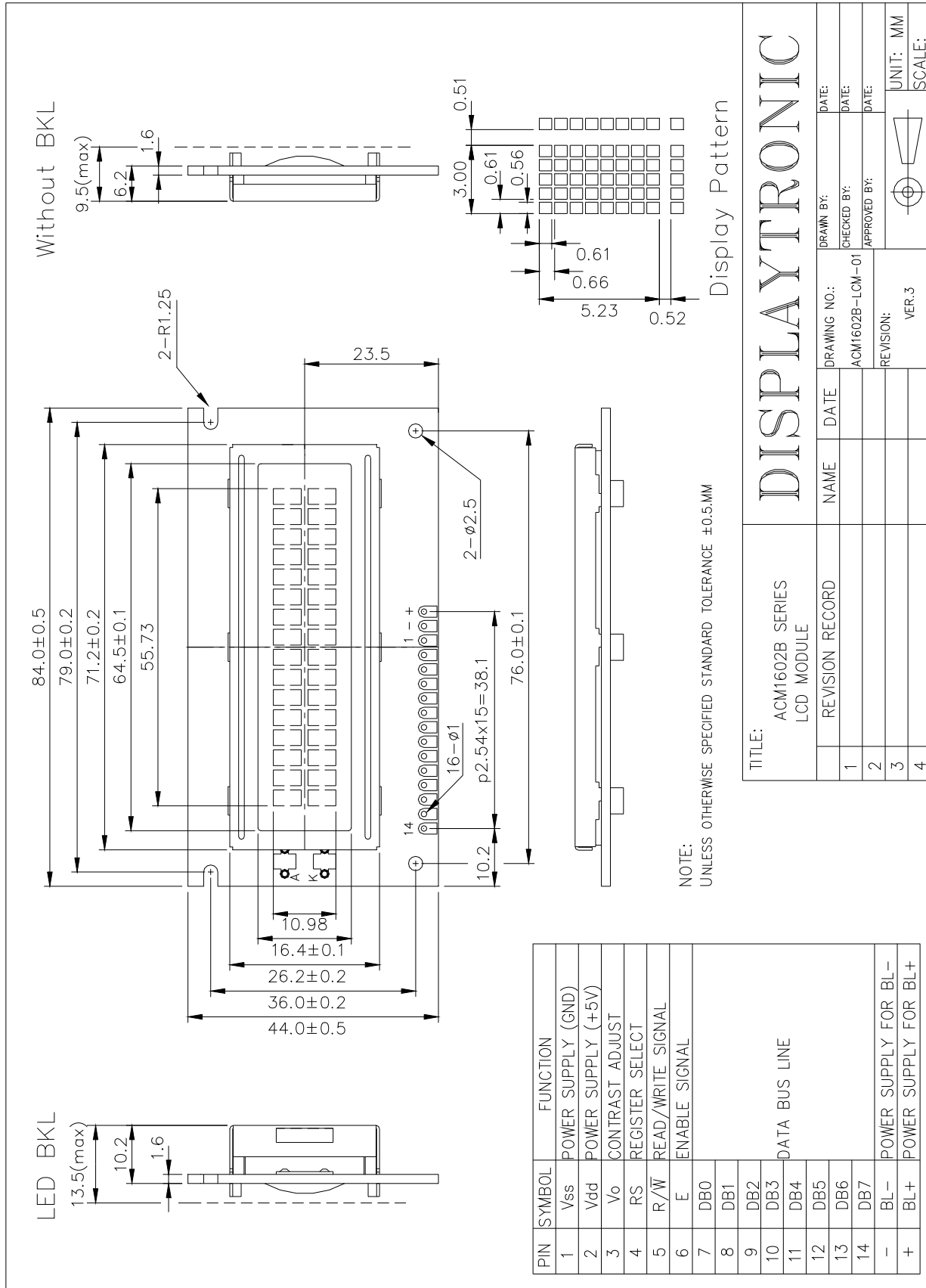

Fig. b Interface timing (data read)



9.0 MECHANICAL DIAGRAM



**10.0 RELIABILITY TEST**

Storage Condition	Content	Evaluations and Assessment*			
		Current Consumption	Oozing	Contrast	Other Appearances
Operation at high temperature and humidity	40°C,90% RH,240hrs	Twice initial value or less	none	More than 80% of initial value	No abnormality
High temperature storage	60°C, 240hrs	Twice initial value or less	none	More than 80% of initial value	No abnormality
Low temperature storage	-20°C, 240hrs	Twice initial value or less		More than 80% of initial value	No abnormality

\*Evaluations and assessment to be made two hours after returning to room temperature (25°C±5°C).

\*The LCDs subjected to the test must not have dew condensation.

## 11.0 DISPLAY INSTRUCTION TABLE

COMMAND	R S	R/ W	DB 7	DB 6	DB 5	DB 4	DB 3	DB 2	DB 1	DB 0	DESCRIPTION	Executing time fosc=250khz
Clear Display	0	0	0	0	0	0	0	0	0	1	Clears Display & Returns to Address 0.	1.64ms
Cursor at Home	0	0	0	0	0	0	0	0	1	x	Returns Cursor to Address 0. Also returns the display being shifted to the original position. DDRAM contents remain unchanged.	1.64ms
Entry Mode Set	0	0	0	0	0	0	0	1	I/D	S	I/D: Set Cursor Moving Direction I/D=1: Increment I/D=0: Decrement  S: Specify Shift of Display S=1: The display is shifted S=0: The display is not shifted	40μs
Display ON/OFF Control	0	0	0	0	0	0	1	D	C	B	Display D=1: Display on D=0: Display off Cursor C=1: Cursor on C=0: Cursor off Brink B=1: Brink on B=0: Brink off	40μs
Cursor / Display Shift	0	0	0	0	0	1	S/C	R/L	x	x	Moves cursor or shifts the display w/o changing DD RAM contents S/C=0: Cursor Shift (RAM unchanged) S/C=1: Display Shift (RAM unchanged) R/L=1: Shift to the Right R/L=0: Shift to the Left	40μs
Function Set	0	0	0	0	1	DL	N	F	x	x	Sets data bus length (DL), # of display lines (N), and character fonts (F). DL=1: 8 bits            F=0: 5x7 dots DL=0: 4 bits            F=1: 5x10 dots N=0: 1 line display N=1: 2 lines display	40μs
Set CG RAM Address	0	0	0	1	Character Generator (CG) RAM Address					Sets CG RAM address. CG RAM data is sent and received after this instruction.		40μs
Set DD RAM Address	0	0	1	Display Data (DD) RAM Address / Cursor Address					Sets DD RAM address. DD Ram data is sent and received after this instruction.		40μs	
Busy Flag / Address Read	0	1	B F	Address counter used for both DD & CG RAM address					Reads Busy Flag (BF) and address counter contents.		40μs	
Write Data	1	0	Write Data								Writes data into DDRAM or CGRAM.	46μs
Read Data	1	1	Read Data								Reads data from DDRAM or CGRAM.	46μs

x: Don't Care.

12.0 STANDARD CHARACTER PATTERNS

Lower 4 Bits \ Upper 4 Bits	0000	0001	0010	0011	0100	0101	0110	0111	1000	1001	1010	1011	1100	1101	1110	1111	
xxxx0000	CG RAM (1)			0	a	P	`	P				-	夕	≡	α	ρ	
xxxx0001	(2)		!	1	A	Q	a	q			。	ア	チ	△	≡	q	
xxxx0010	(3)		"	2	B	R	b	r			「	イ	ツ	×	≡	θ	
xxxx0011	(4)		#	3	C	S	c	s			」	ウ	テ	≡	ε	∞	
xxxx0100	(5)		\$	4	D	T	d	t			、	エ	ト	≡	μ	Ω	
xxxx0101	(6)		%	5	E	U	e	u			・	オ	ナ	≡	1	ε	ü
xxxx0110	(7)		&	6	F	V	f	v			ヲ	カ	ニ	≡	ヨ	ρ	Σ
xxxx0111	(8)		'	7	G	W	g	w			ア	キ	ヌ	≡	ラ	g	π
xxxx1000	(1)		(	8	H	X	h	x			イ	ク	ネ	≡	リ	μ	∞
xxxx1001	(2)		)	9	I	Y	i	y			ウ	ケ	ル	≡	レ	'	y
xxxx1010	(3)		*	:	J	Z	j	z			エ	コ	ハ	≡	レ	j	≠
xxxx1011	(4)		+	;	K	[	k	[			オ	サ	ヒ	≡	ロ	°	≠
xxxx1100	(5)		,	<	L	¥	l	l			カ	シ	フ	≡	ワ	≠	≠
xxxx1101	(6)		-	=	M	]	m	]			ユ	ヌ	ハ	≡	ン	≠	÷
xxxx1110	(7)		.	>	N	^	n	+			ヨ	セ	ホ	≡	°	≠	
xxxx1111	(8)		/	?	O	_	o	+			ッ	ソ	マ	≡	°	ö	■

Note: The character generator RAM is the RAM with which the user can rewrite character patterns by program.