

RECTANGULAR CONNECTORS

FCN-360 SERIES

■ FEATURES

- Many applications
Various connectors are available for connection by means of soldering, wire wrapping, crimping, PC board mounting, and insulation displacement connection (IDC). The user can choose a plug and jack combination that best meet each application.
- Small size for high-density mounting
The connectors are small with a contact and terminal pitch of 2.54 mm (0.100 in.) between pins and between rows and are thus well suited for high-density mounting.
- Sturdy shell guide
Sturdy shell guides are used to prevent mismatching and to protect the pins.
- Excellent cost performance
Streamlined design and automated manufacturing, including use of partial solder plating, provide excellent cost performance.

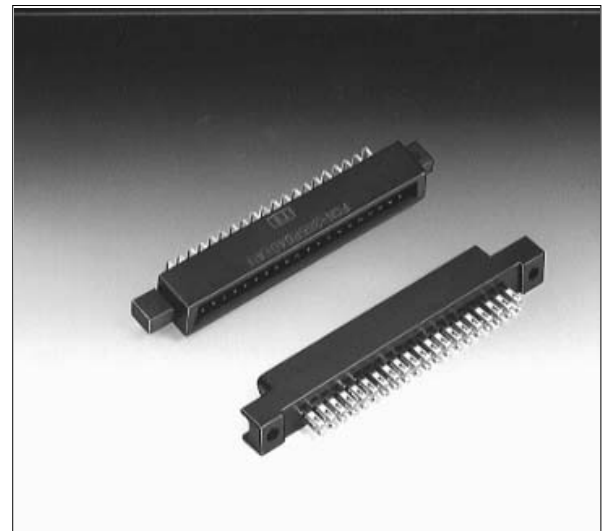

■ SPECIFICATIONS

Item		Specification
Operating temperature range		-55°C to +85°C
Current Rating		DC 3 A (IDC type: 1 A)
Voltage Rating		AC 250 V
Contact resistance		15 mΩ max. (DC 6 V, 0.3 A)
Insulation resistance		1000 MΩ min. (DC 500 V)
Dielectric withstanding voltage		AC 500 V for 1 minute
Insertion force		2.5 kg max. (8 contacts), 20 kg max. (64 contacts)
Withdrawal force		0.3 kg min. (8 contacts), 2.3 kg min. (64 contacts)
Applicable wire	Soldering	φ0.60 mm (0.024 in.) max, AWG #23 or less
	Wire-wrapping	φ0.32 mm (0.013 in.) to φ0.26 mm (0.010 in.), AWG #28 to #30
	Crimping	Standard contacts φ0.51 mm (0.020 in.) to φ0.32 mm (0.013 in.), AWG #24 to #28, insulator φ1.2 mm (0.047 in.) max. Contacts for thick wires φ0.64 mm (0.025 in.) to φ0.32 mm (0.013 in.), AWG #22 to #28, insulator φ1.7 (0.067 in.) max.
	IDC	Flat cable 1.27 mm (0.050 in.) pitch, AWG #28 (stranded wire), AWG #30 (solid wire)
Applicable PC board		1.6 mm (0.063 in.) standard thick

■ MATERIALS

Item	Material
Insulator	Polyester (363J: PC94V-2)
Conductor	Copper alloy
Plating	Gold plating, silver plating

FCN-360 Series

APPLICATION EXAMPLE

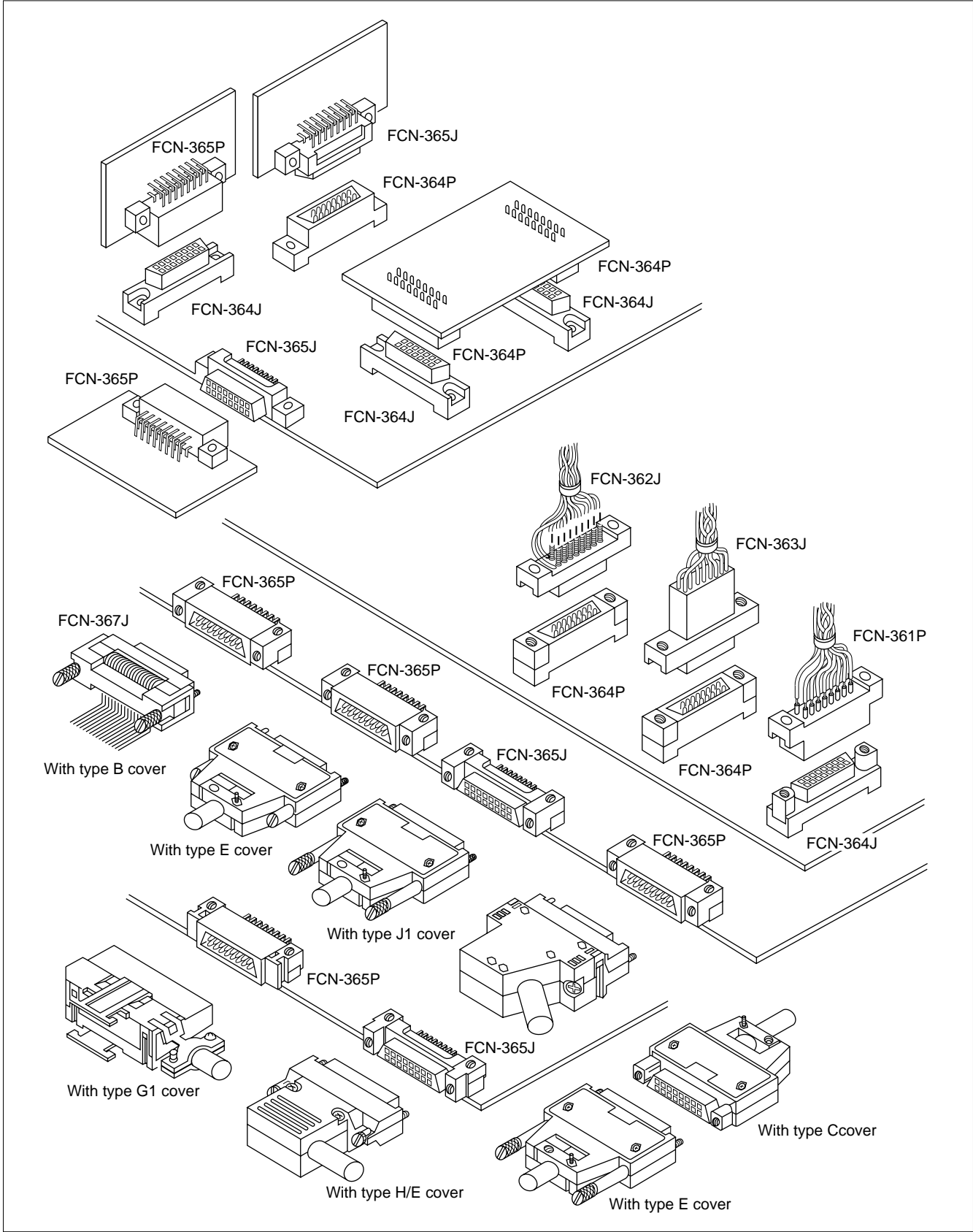

STRAIGHT TYPE (JACK)

■ DIMENSIONS

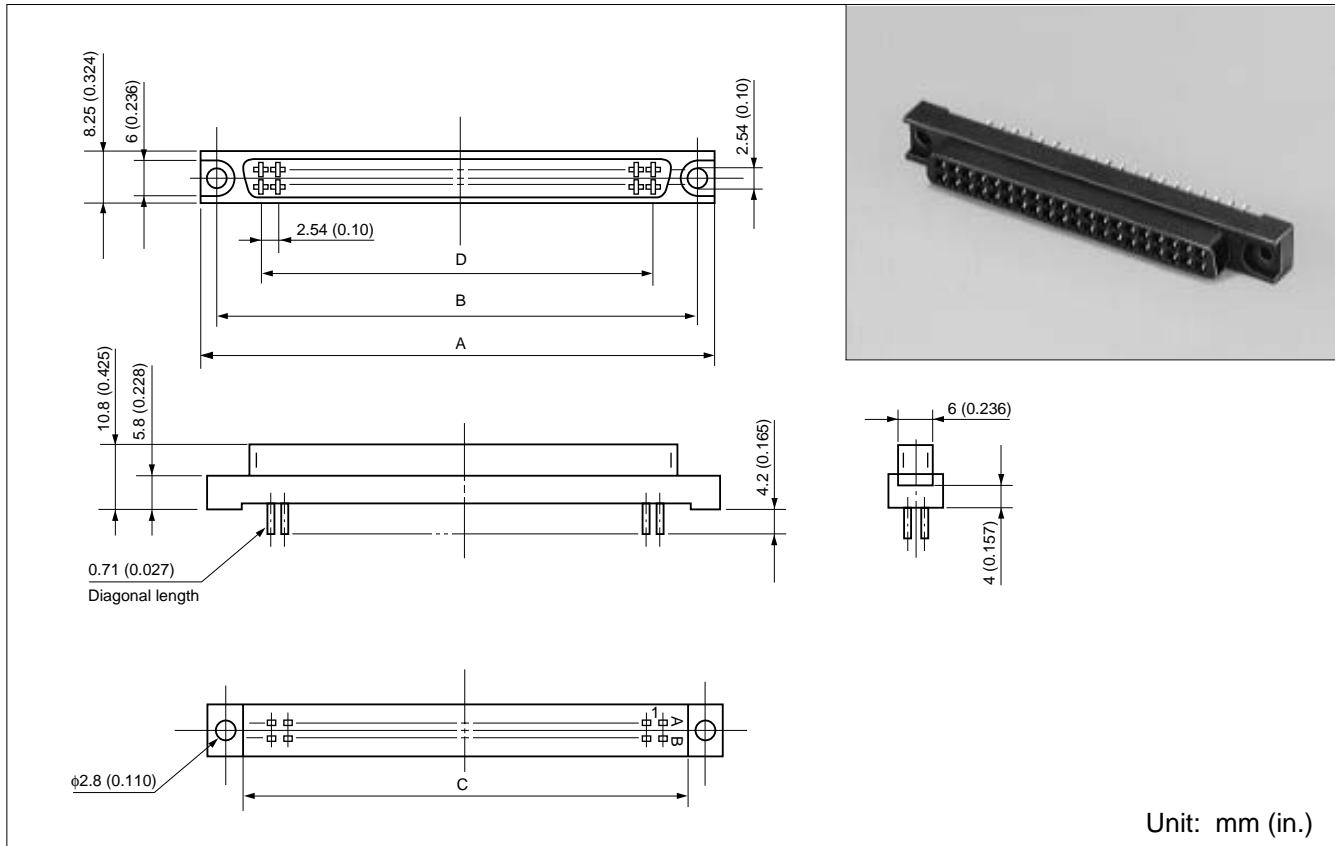

■ BOARD MOUNTING HOLE LAYOUT

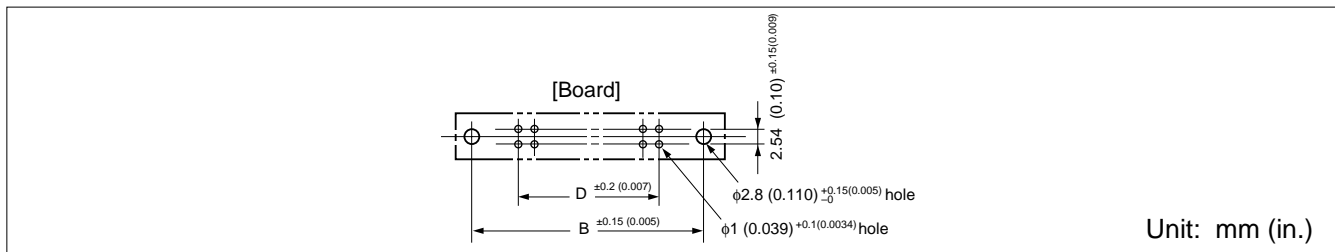

■ PART NUMBERS AND DIMENSIONS

Number of contacts	Part number	Dimensions: mm (in.)			
		A	B	C	D
8	FCN-364J008-AU	28.84 (1.135)	23.34 (0.918)	17.84 (0.702)	7.62 (0.3)
16	FCN-364J016-AU	39.0 (1.535)	33.5 (1.318)	28.0 (1.102)	17.78 (0.7)
24	FCN-364J024-AU	49.16 (1.935)	43.66 (1.718)	38.16 (1.502)	27.94 (1.1)
32	FCN-364J032-AU	59.32 (2.335)	53.82 (2.118)	48.32 (1.902)	38.1 (1.5)
40	FCN-364J040-AU	69.48 (2.735)	63.98 (2.518)	58.48 (2.302)	48.26 (1.9)
48	FCN-364J048-AU	79.64 (3.135)	74.14 (2.918)	68.64 (2.702)	58.42 (2.3)
56	FCN-364J056-AU	89.8 (3.535)	84.3 (3.318)	78.8 (3.102)	68.58 (2.7)
64	FCN-364J064-AU	99.96 (3.935)	94.46 (3.718)	88.96 (3.502)	78.74 (3.1)

ACCESSORIES

■ MOUNTING SYLE

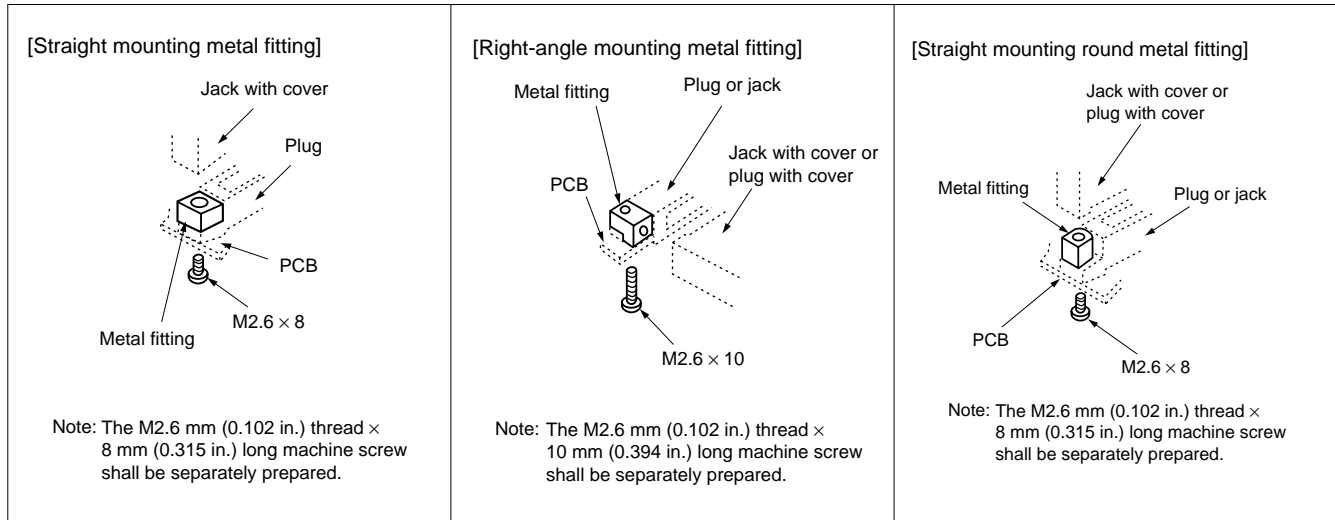

■ SELECTION OF METAL FITTINGS ACCORDING TO COMBINATION OF CONNECTORS AND COVERS

Jack \ Plug		Cover mounting side										
		361J		362J		363J		364J		367J		
		With cover	Without cover	With cover	Without cover	With cover	Without cover	With cover	Without cover	With cover	Without cover	
Metal fitting mounting side	361P	Metal fitting part number	FCN-360A4	FCN-360A5	FCN-360A4	FCN-360A5	FCN-360A4	FCN-360A5	FCN-360A4	FCN-360A5	—	FCN-360A5
	362P		FCN-360A1	FCN-360A6	FCN-360A1	FCN-360A6	FCN-360A1	FCN-360A6	FCN-360A1	FCN-360A6	—	FCN-360A6
	364P		FCN-360A1	FCN-360A6	FCN-360A1	FCN-360A6	FCN-360A1	FCN-360A6	FCN-360A1	FCN-360A6	—	FCN-360A6
	365P		FCN-360A2	FCN-360A3	FCN-360A2	FCN-360A3	FCN-360A2	FCN-360A3	FCN-360A2	FCN-360A3	—	FCN-360A3

Jack \ Plug		Cover mounting side						
		361P		361P		364P		
		With cover	Without cover	With cover	Without cover	With cover	Without cover	
Metal fitting mounting side	361J	Metal fitting part number	FCN-360A4	FCN-360A5	—	FCN-360A7	—	FCN-360A7
	362J		FCN-360A4	FCN-360A5	—	FCN-360A7	—	FCN-360A7
	363J		FCN-360A4	FCN-360A5	—	FCN-360A7	—	FCN-360A7
	364J		FCN-360A4	FCN-360A5	—	FCN-360A7	—	FCN-360A7
	365J		FCN-360A10 (FCN-360A8)	FCN-360A9	—	FCN-360A9	—	FCN-360A9
	367J		FCN-360A4	FCN-360A5	—	FCN-360A7	—	FCN-360A7

Note: When the jack or plug without a cover (shaded part) is used, have M2.6 × 8 mm machine screws ready in order to tighten the connector.

FCN-360 Series

SHAPES AND DIMENSIONS OF METAL FITTINGS

1. Straight Mounting Metal Fittings

Shape	Symbol	Part number	FCN-360A1	FCN-360A6
	A		5.3 (0.208)	6.3 (0.248)

2. Right-angle Mounting Metal Fittings

Shape	Symbol	Part number	FCN-360A2	FCN-360A3
	B		3 (0.118)	4 (0.157)
	C		9 (0.354)	10 (0.393)

Shape	Symbol	Part number	FCN-360A8	FCN-360A9
	B		5.3 (0.208)	6.3 (0.248)
	C		13.3 (0.523)	14.3 (0.526)

Symbol	Part number	FCN-360A10

Symbol	Part number	FCN-360A11

3. Straight Mounting Round Metal Fittings

Shape	Symbol	Part number	FCN-360A4	FCN-360A5	FCN-360A7
	D		7.1 (0.279)	9.9 (0.389)	8.1 (0.318)