

PC BOARD CONNECTORS

700 SERIES

■ FEATURES

The 700 series connector has a superior ejector with a unique flexible latch. Terminals are palladium plated and have an excellent cost performance ratio. The solder dip section is a 0.5 mm (0.020 in.) square and can be used in a ϕ 0.8 mm (0.031 in.) through hole. Special strain relief prevents breakage. Two kinds of keys and bump polarization prevent incorrect insertion. Connectors with 4 mm (0.157 in.) long tails are also available for mounting on multilayer PC boards.

■ SPECIFICATIONS

Item	Specification
Operating temperature range	-55°C to +105°C
Current rating	DC 1 A
Voltage rating	AC 250 V
Contact resistance	120 m Ω max. (DC 6 V, 0.1 A)
Insulation resistance	1000 M Ω min. (DC 500 V)
Dielectric strength	AC 500 V for 1 minute
Insertion force	3.5 kg max. (10 pins), 21 kg max. (60 pins)
Withdrawal force	0.25 kg min. (10 pins), 2.5 kg min. (60 pins)
Applicable wire	Flat cable: 1.27 mm (0.050 in.) pitch AWG #28 (stranded wires) or AWG #30 (solid wire)
Applicable wire-wrapping wire	AWG #26 to #30 (solid wire)
Applicable PC board (standard)	1.6 mm (0.062 in.) for standard terminal, 3.2 mm (0.125 in.) for long tail

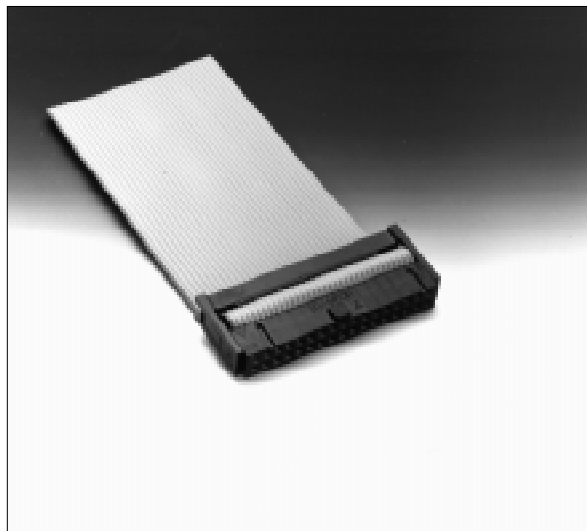

■ MATERIALS

Item	Materials	
Insulating material	Polyester (UL94V-0)	
Conductor	Copper alloy	
Plating	Contact	Gold
	Terminal	Palladium

IDC HEADER M6 SERIES

■ DIMENSIONS

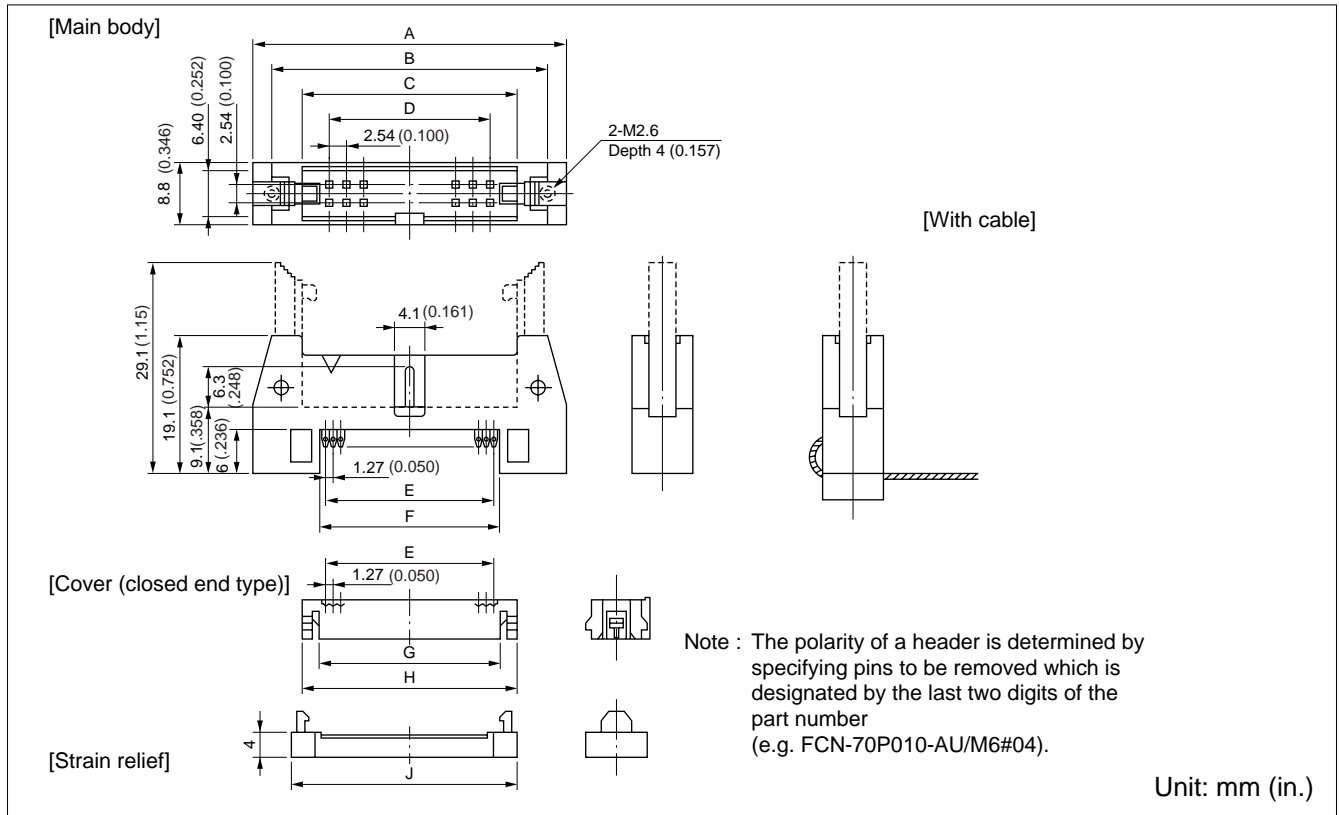

■ PART NUMBERS AND DIMENSIONS

Number of contacts	Without mini latch	With mini latch	Dimensions: mm (in.)								
			A	B	C	D	E	F	G	H	J
10	FCN-707P010-AU/0	FCN-707P010-AU/M6	32.0 (1.25)	26.80 (1.06)	18.3 (.720)	10.16 (.400)	11.43 (.450)	13.43 (.528)	13.43 (.528)	18.3 (.720)	20.2 (.795)
14	FCN-707P014-AU/0	FCN-707P014-AU/M6	37.1 (1.46)	31.90 (1.26)	23.4 (.921)	15.24 (.600)	16.51 (.650)	18.53 (.729)	18.53 (.729)	23.4 (.921)	25.3 (.996)
16	FCN-707P016-AU/0	FCN-707P016-AU/M6	39.62 (1.56)	34.42 (1.36)	25.9 (1.02)	17.78 (.700)	19.05 (.750)	21.03 (.828)	21.03 (.828)	25.9 (1.02)	27.8 (1.09)
20	FCN-707P020-AU/0	FCN-707P020-AU/M6	44.7 (1.76)	39.50 (1.56)	31.0 (1.22)	22.86 (.900)	24.13 (.950)	26.13 (1.03)	26.13 (1.03)	31.0 (1.22)	32.9 (1.29)
26	FCN-707P026-AU/0	FCN-707P026-AU/M6	52.32 (2.06)	47.12 (1.86)	38.6 (1.52)	30.48 (1.20)	31.75 (1.25)	33.73 (1.33)	33.73 (1.33)	38.6 (1.52)	40.5 (1.59)
30	FCN-707P030-AU/0	FCN-707P030-AU/M6	57.4 (2.26)	52.20 (2.06)	43.7 (1.72)	35.56 (1.40)	36.83 (1.45)	38.83 (1.53)	38.83 (1.53)	43.7 (1.72)	45.6 (1.79)
34	FCN-707P034-AU/0	FCN-707P034-AU/M6	62.48 (2.46)	57.28 (2.26)	48.8 (1.92)	40.64 (1.60)	41.91 (1.65)	43.93 (1.73)	43.93 (1.73)	48.8 (1.92)	50.7 (2.00)
40	FCN-707P040-AU/0	FCN-707P040-AU/M6	70.1 (2.76)	64.90 (2.56)	56.4 (2.22)	48.26 (1.90)	49.53 (1.95)	51.53 (2.03)	51.53 (2.03)	56.4 (2.22)	58.3 (2.29)
50	FCN-707P050-AU/0	FCN-707P050-AU/M6	82.8 (3.26)	77.60 (3.06)	69.1 (2.72)	60.96 (2.40)	62.23 (2.45)	64.23 (2.53)	64.23 (2.53)	69.1 (2.72)	71.0 (2.79)
60	FCN-707P060-AU/0	FCN-707P060-AU/M6	95.5 (3.76)	90.30 (3.56)	81.8 (3.22)	73.66 (2.90)	74.93 (2.95)	76.93 (3.03)	76.93 (3.03)	81.8 (3.22)	83.7 (3.29)

Fujitsu Components International Headquarter Offices

Japan

Fujitsu Component Limited
Gotanda-Chuo Building
3-5, Higashigotanda 2-chome, Shinagawa-ku
Tokyo 141, Japan
Tel: (81-3) 5449-7010
Fax: (81-3) 5449-2626
Email: promothq@ft.ed.fujitsu.com
Web: www.fcl.fujitsu.com

North and South America

Fujitsu Components America, Inc.
250 E. Caribbean Drive
Sunnyvale, CA 94089 U.S.A.
Tel: (1-408) 745-4900
Fax: (1-408) 745-4970
Email: marcom@fcai.fujitsu.com
Web: www.fcai.fujitsu.com

Europe

Fujitsu Components Europe B.V.
Diamantlaan 25
2132 WV Hoofddorp
Netherlands
Tel: (31-23) 5560910
Fax: (31-23) 5560950
Email: info@fceu.fujitsu.com
Web: www.fceu.fujitsu.com

Asia Pacific

Fujitsu Components Asia Ltd.
102E Pasir Panjang Road
#04-01 Citilink Warehouse Complex
Singapore 118529
Tel: (65) 6375-8560
Fax: (65) 6273-3021
Email: fcal@fcal.fujitsu.com
www.fcal.fujitsu.com

© 2002 Fujitsu Components America, Inc. All company and product names are trademarks or registered trademarks of their respective owners. Rev. 10/2002