

KTB050BLCI Blue Colour

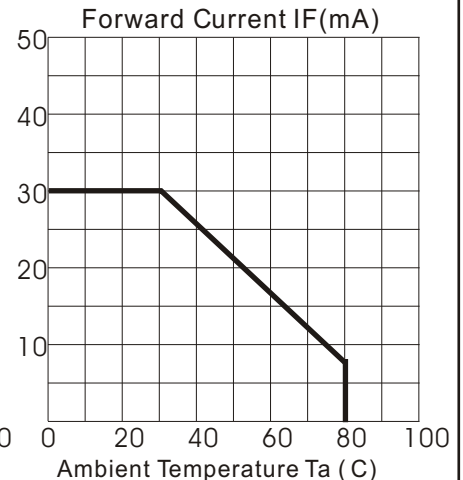
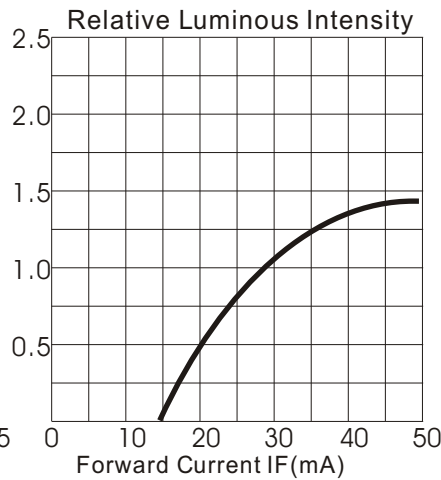
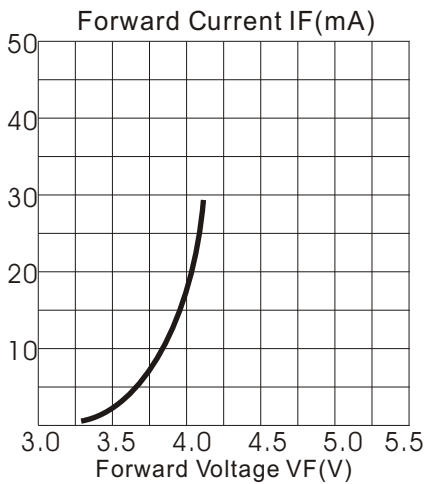
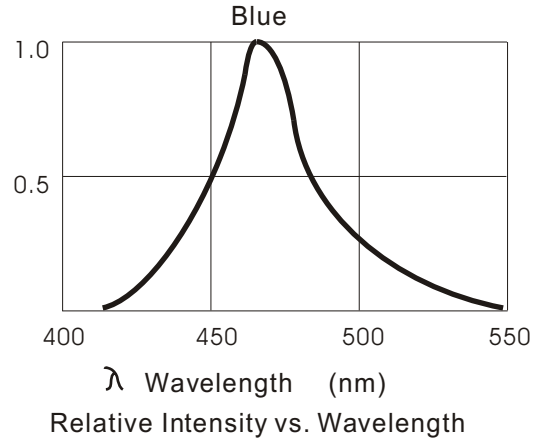
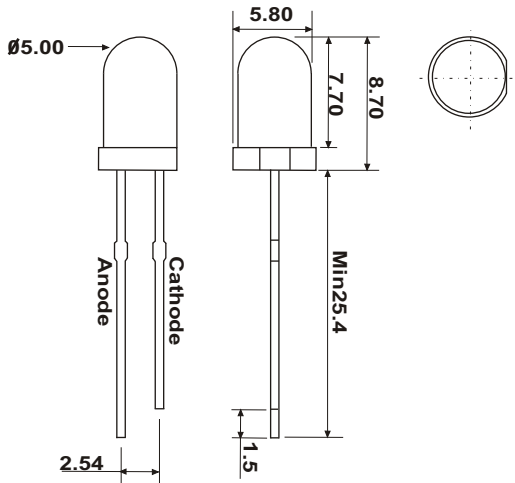

Absolute Maximum Ratings at Ta = 25°C

Parameter	Symbol	Condition	Min.	Typ.	Max.	Unit
Forward Voltage	Vf	If=20mA	3.6		4.0	V
Reverse Voltage	Vr	If=20mA	5.0		5.0	V
Luminous Intensity	Iv	If=20mA		0.5		cd
Wavelength	Dλ	If=20mA		470		nm
LENS Color	Water Clear					

LED working lifetime 100,000 hrs

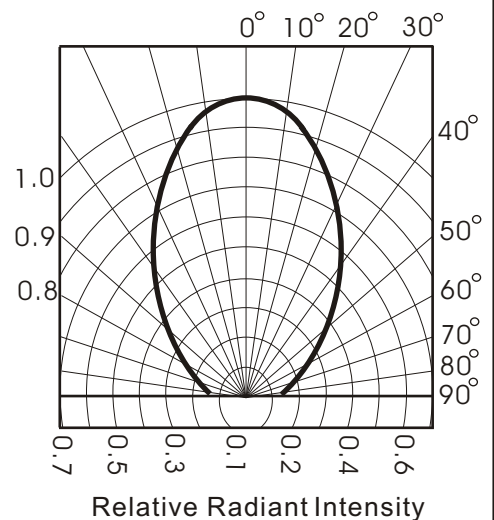

Sink Output Current VS Operating Voltage

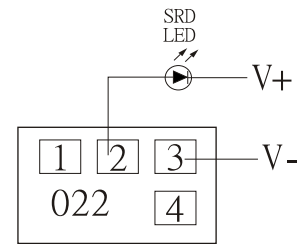
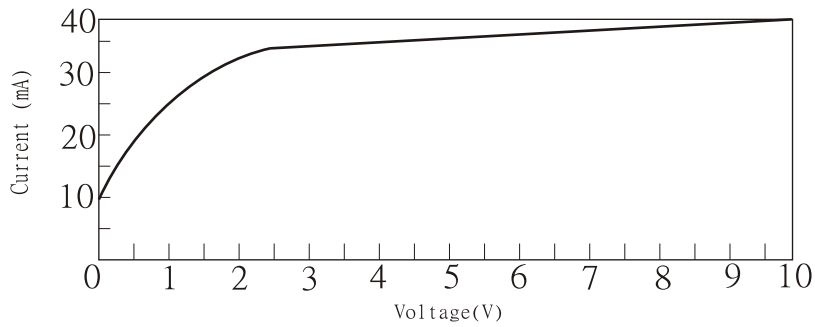

IC 022

Source Output Current VS Operating Voltage

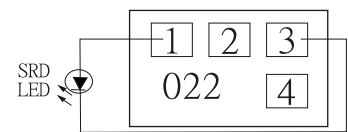
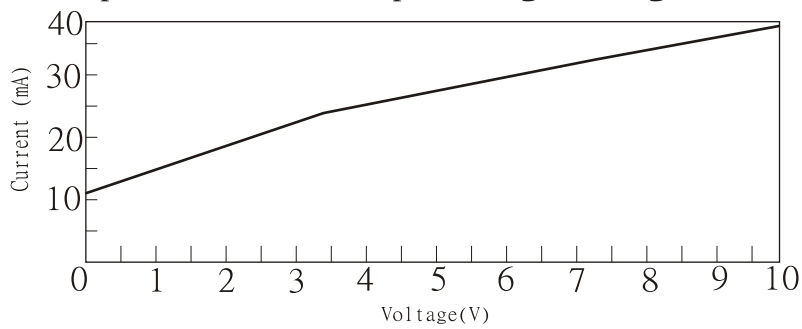

Ic022

Blinking Frequency VS Operating Voltage

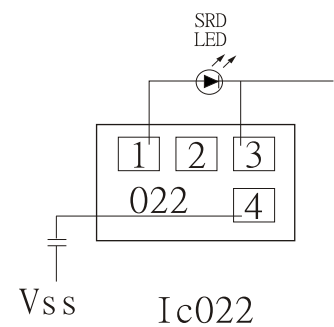
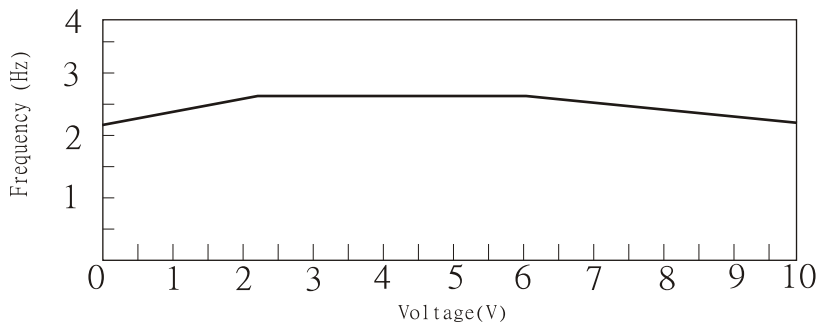

Ic022