



# MOTOROLA SEMICONDUCTORS

P.O. BOX 20912 • PHOENIX, ARIZONA 85036

## VOLTAGE REFERENCE FAMILY

The MC1404 series of ICs is a family of temperature-compensated voltage references for precision data conversion applications, such as A/D, D/A, V/F, and F/V. Advances in laser-trimming and ion-implanted devices, as well as monolithic fabrication techniques, make these devices stable and accurate to 12 bits over both military and commercial temperature ranges. In addition to excellent temperature stability, these parts offer excellent long-term stability and low noise.

- Output Voltages: Standard, 5.0 V, 6.25 V, 10 V
- Trimmable Output:  $> \pm 6\%$
- Wide Input Voltage Range:  $V_{REF} + 2.5 \text{ V}$  to 40 V
- Low Quiescent Current: 1.25 mA Typical
- Temperature Coefficient: 10 ppm/ $^{\circ}\text{C}$  Typical
- Low Output Noise: 12  $\mu\text{V}$  p-p Typical
- Excellent Ripple Rejection:  $> 80 \text{ dB}$  Typical

### TYPICAL APPLICATIONS

- Voltage Reference for 8-12 Bit D/A Converters
- Low  $T_C$  Zener Replacement
- High Stability Current Reference
- MPU D/A and A/D Applications

# MC1404 MC1404A MC1504 MC1504A

## PRECISION LOW-DRIFT VOLTAGE REFERENCES

5.0, 6.25, and 10-VOLT OUTPUT VOLTAGES

LASER TRIMMED SILICON  
MONOLITHIC INTEGRATED CIRCUIT

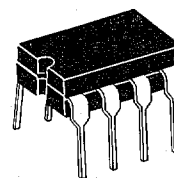

**U SUFFIX**  
CERAMIC PACKAGE  
CASE 693

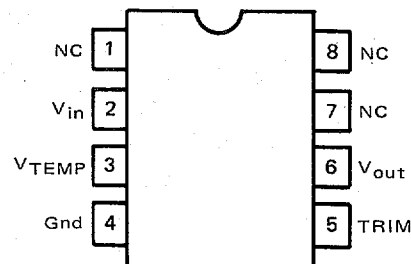
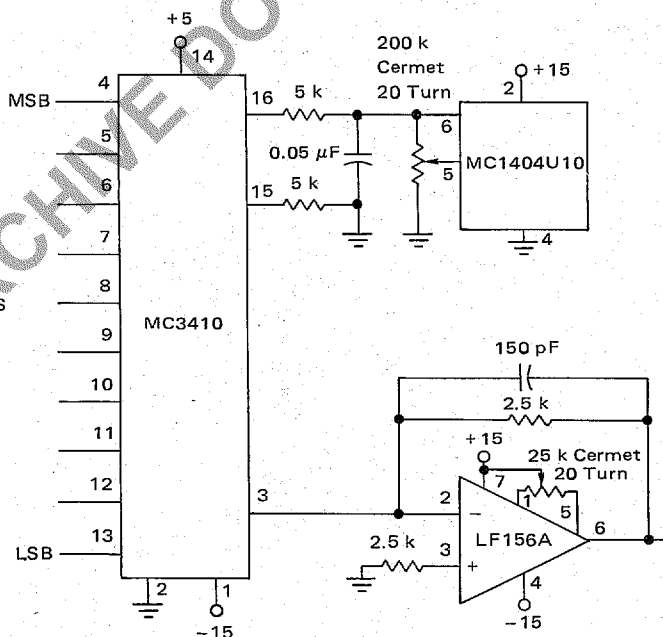

FIGURE 1 - VOLTAGE OUTPUT 10-BIT DAC USING MC1404U10



## ORDERING INFORMATION

PACKAGE (ALL TYPES)  
Ceramic DIP

Device	Temperature Range
<b>5.0 Volts</b>	
MC1504U5	-55 $^{\circ}\text{C}$ to +125 $^{\circ}\text{C}$
MC1504AU5	-55 $^{\circ}\text{C}$ to +125 $^{\circ}\text{C}$
MC1404U5	0 $^{\circ}\text{C}$ to +70 $^{\circ}\text{C}$
MC1404AU5	0 $^{\circ}\text{C}$ to +70 $^{\circ}\text{C}$
<b>6.25 Volts</b>	
MC1504U6	-55 $^{\circ}\text{C}$ to +125 $^{\circ}\text{C}$
MC1504AU6	-55 $^{\circ}\text{C}$ to +125 $^{\circ}\text{C}$
MC1404U6	0 $^{\circ}\text{C}$ to +70 $^{\circ}\text{C}$
MC1404AU6	0 $^{\circ}\text{C}$ to +70 $^{\circ}\text{C}$
<b>10 Volts</b>	
MC1504U10	-55 $^{\circ}\text{C}$ to +125 $^{\circ}\text{C}$
MC1504AU10	-55 $^{\circ}\text{C}$ to +125 $^{\circ}\text{C}$
MC1404U10	0 $^{\circ}\text{C}$ to +70 $^{\circ}\text{C}$
MC1404AU10	0 $^{\circ}\text{C}$ to +70 $^{\circ}\text{C}$

## MAXIMUM RATINGS

Rating	Symbol	Value	Unit
Input Voltage	$V_I$	40	V
Storage Temperature	$T_{stg}$	-65 to +150	°C
Junction Temperature	$T_J$	+175	°C
Operating Ambient Temperature Range	$T_A$	-55 to +125 0 to +70	°C °C

ELECTRICAL CHARACTERISTICS ( $V_{in} = 15$  Volts,  $T_A = 25^\circ\text{C}$  and Trim Terminal not connected unless otherwise noted)

Characteristic	Symbol	MC1404, A			MC1504, A			Unit
		Min	Typ	Max	Min	Typ	Max	
Output Voltage ( $I_O = 0$ mA)	$V_O$							Volt
U5, AU5		4.95	5.00	5.05	4.95	5.00	5.05	
U6, AU6		6.19	6.25	6.31	6.19	6.25	6.31	
U10, AU10		9.90	10	10.10	9.90	10	10.10	
Output Voltage Tolerance	—	—	$\pm 0.1$	$\pm 1.0$	—	$\pm 0.1$	$\pm 1.0$	%
Output Trim Range (Figure 10) ( $R_P = 100$ k $\Omega$ )	$\Delta V_{TRIM}$	$\pm 6.0$	—	—	$\pm 6.0$	—	—	%
Output Voltage Temperature Coefficient, Over Full Temperature Range	$\Delta V_O/\Delta T$							ppm/°C
MC1404, MC1504		—	10	40	—	—	55	
MC1404A, MC1504A		—	10	25	—	—	25	
Maximum Output Voltage Change Over Temperature Range	$\Delta V_O$							mV
MC1404U5, MC1504U5		—	—	14	—	—	50	
MC1404AU5, MC1504AU5		—	—	9.0	—	—	23	
MC1404U6, MC1504U6		—	—	17.5	—	—	62	
MC1404AU6, MC1504AU6		—	—	11	—	—	28	
MC1404U10, MC1504U10		—	—	28	—	—	99	
MC1404AU10, MC1504AU10		—	—	18	—	—	45	
Line Regulation (1) ( $V_{in} = V_{out} + 2.5$ V to 40 V, $I_{out} = 0$ mA)	Reg <sub>LINE</sub>	—	2.0	6.0	—	2.0	6.0	mV
Load Regulation (1) ( $0 \leq I_O \leq 10$ mA)	Reg <sub>LOAD</sub>	—	—	10	—	—	10	mV
Quiescent Current ( $I_O = 0$ mA)	$I_Q$	—	1.2	1.5	—	1.2	1.5	mA
Short Circuit Current	$I_{sc}$	15	20	30	—	—	30	mA
Long Term Stability	—	—	25	—	—	25	—	ppm/1000 hrs

Note 1: Includes thermal effects.

DYNAMIC CHARACTERISTICS ( $V_{in} = 15$  V,  $T_A = 25^\circ\text{C}$  all voltage ranges unless otherwise noted)

Characteristic	Symbol	MC1404, A			MC1504, A			Unit
		Min	Typ	Max	Min	Typ	Max	
Turn-On Settling Time (to $\pm 0.01\%$ )	$t_S$	—	50	—	—	50	—	$\mu\text{s}$
Output Noise Voltage — P to P (Bandwidth 0.1 to 10 Hz)	$e_n$	—	12	—	—	12	—	$\mu\text{V}$
Small-Signal Output Impedance 120 Hz	$r_o$	—	0.15	—	—	0.15	—	$\Omega$
500 Hz		—	0.2	—	—	0.2	—	
Power Supply Rejection Ratio	PSRR	70	80	—	70	80	—	dB



FIGURE 8 – SHORT CIRCUIT CURRENT versus TEMPERATURE

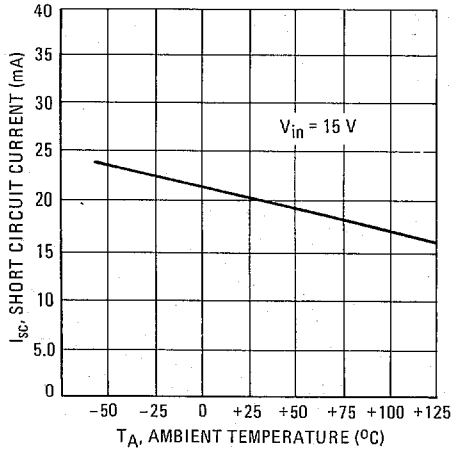

FIGURE 9 – V<sub>TEMP</sub> OUTPUT versus TEMPERATURE

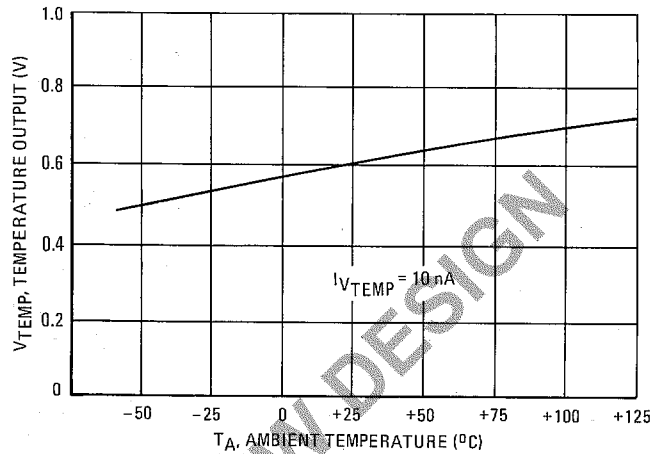
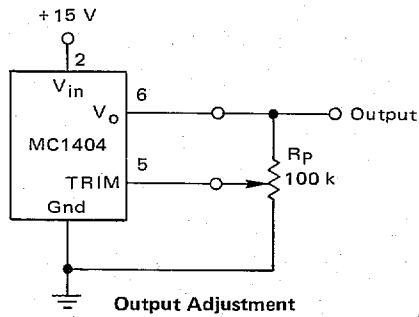

FIGURE 10 – OUTPUT TRIM CONFIGURATION



The MC1404 trim terminal can be used to adjust the output voltage over a ±6% range. For example, the output can be set to 10.000 V or to 10.240 V for binary applications. For trimming, Bourns type 3059, 100 kΩ or 200 kΩ trimpot is recommended.

Although Figure 10 illustrates a wide trim range, temperature coefficients may become unpredictable for trim > ±6.0%.

FIGURE 11 – PRECISION SUPPLY USING MC1404

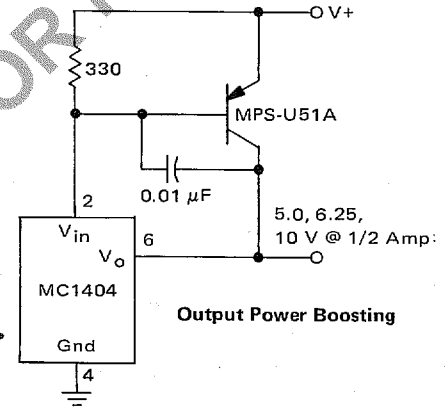

The addition of a power transistor, a resistor, and a capacitor converts the MC1404 into a precision supply with one ampere current capability. At V<sub>+</sub> = 15 V, the MC1404 can carry in excess of 14 mA of load current with good regulation. If the power transistor current gain exceeds 75, a one ampere supply can be realized.

FIGURE 12 – ULTRA STABLE REFERENCE FOR MC1723 VOLTAGE REGULATOR

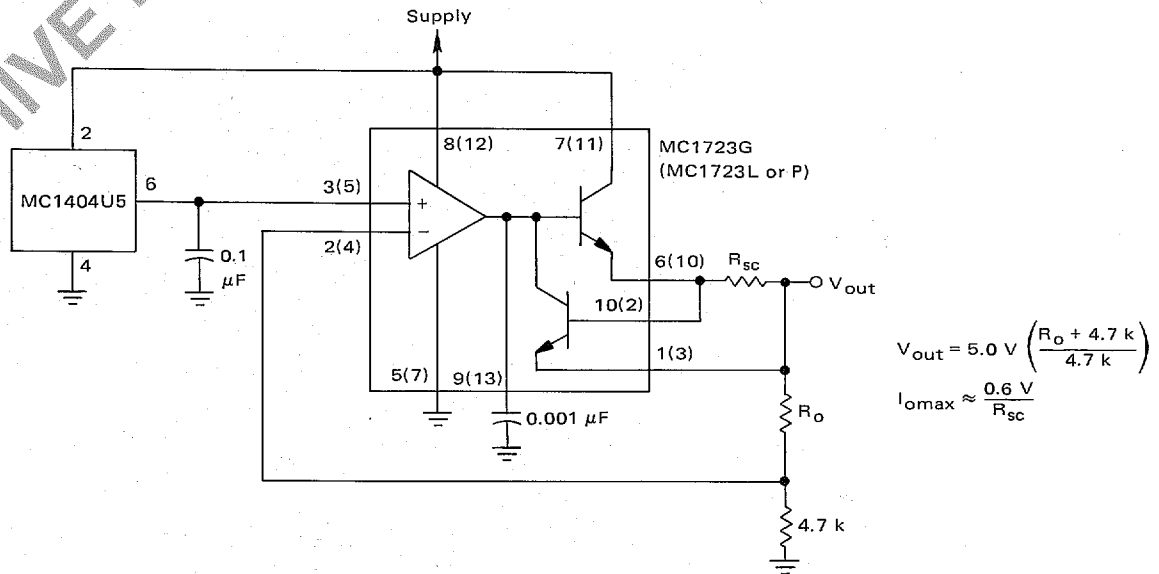



TYPICAL CHARACTERISTICS

FIGURE 2 – SIMPLIFIED DEVICE DIAGRAM

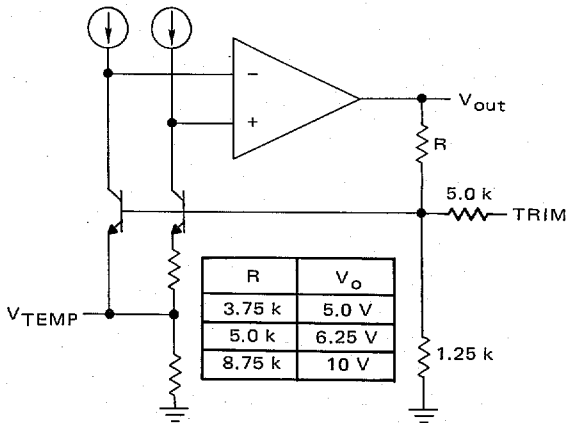

FIGURE 3 – LINE REGULATION versus TEMPERATURE

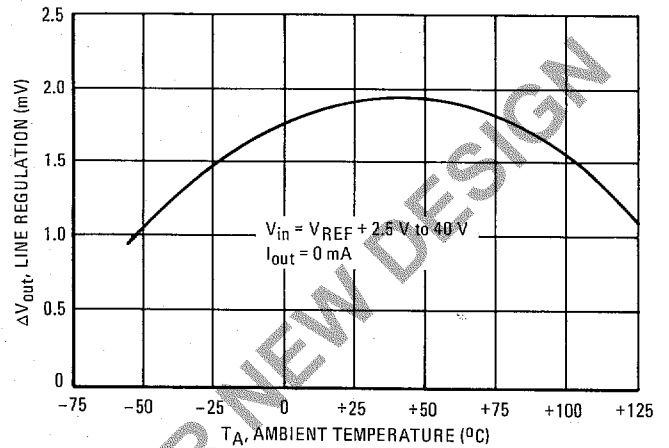

FIGURE 4 – OUTPUT VOLTAGE versus TEMPERATURE  
MC1404U10

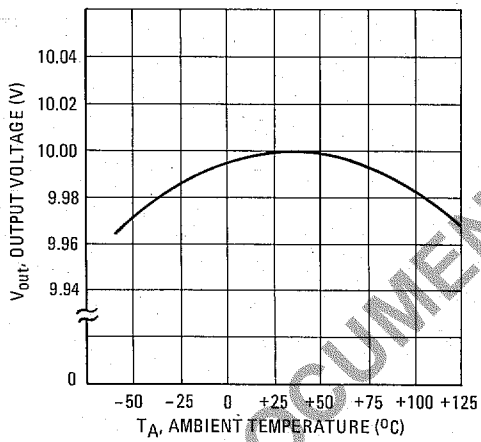

FIGURE 5 – LOAD REGULATION versus TEMPERATURE

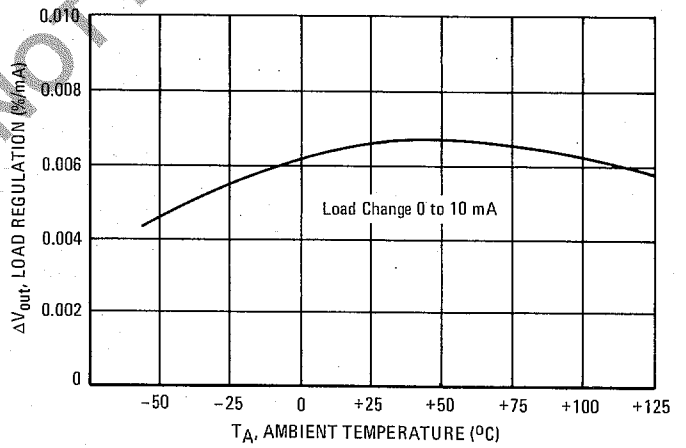

FIGURE 6 – POWER SUPPLY REJECTION RATIO  
versus FREQUENCY

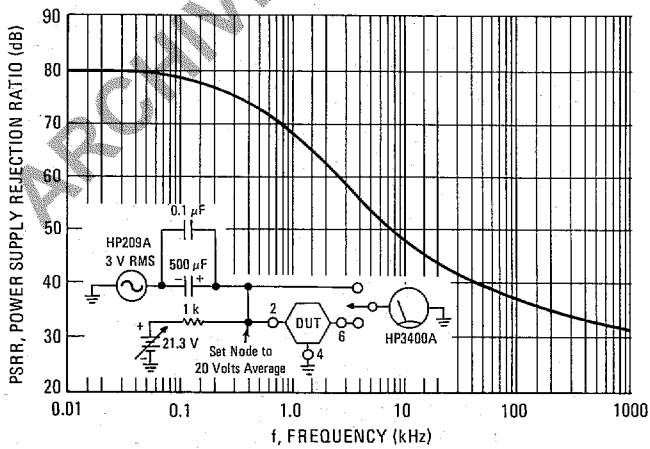
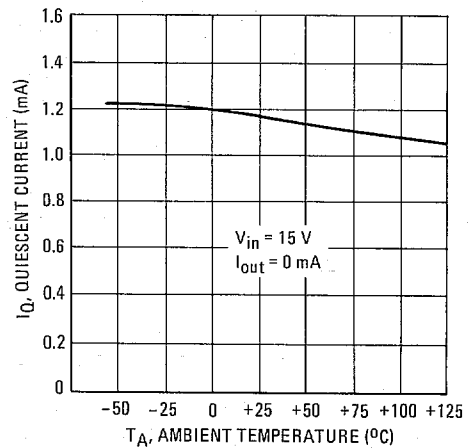

FIGURE 7 – QUIESCENT CURRENT versus TEMPERATURE







MOTOROLA

# SEMICONDUCTORS

P.O. BOX 20912 • PHOENIX, ARIZONA 85036

## MC1404 MC1404A MC1504 MC1504A

### Advance Information

#### VOLTAGE REFERENCE FAMILY

The MC1404 series of ICs is a family of temperature-compensated voltage references for precision data conversion applications, such as A/D, D/A, V/F, and F/V. Advances in laser-trimming and ion-implanted devices, as well as monolithic fabrication techniques, make these devices stable and accurate to 12 bits over both military and commercial temperature ranges. In addition to excellent temperature stability, these parts offer excellent long-term stability and low noise.

- Output Voltages: Standard, 5.0 V, 6.25 V, 10 V
- Trimmable Output:  $> \pm 6\%$
- Wide Input Voltage Range:  $V_{REF} + 2.5 V$  to 40 V
- Low Quiescent Current: 1.25 mA Typical
- Temperature Coefficient: 10 ppm/°C Typical
- Low Output Noise: 12  $\mu V$  p-p Typical
- Excellent Ripple Rejection:  $> 80$  dB Typical

#### TYPICAL APPLICATIONS

- Voltage Reference for 8-12 Bit D/A Converters
- Low  $T_C$  Zener Replacement
- High Stability Current Reference
- MPU D/A and A/D Applications

#### PRECISION LOW-DRIFT VOLTAGE REFERENCES

5.0, 6.25, and 10-VOLT OUTPUT VOLTAGES

LASER TRIMMED SILICON  
MONOLITHIC INTEGRATED CIRCUIT

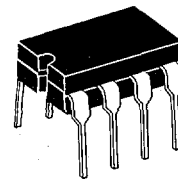

U SUFFIX  
CERAMIC PACKAGE  
CASE 693

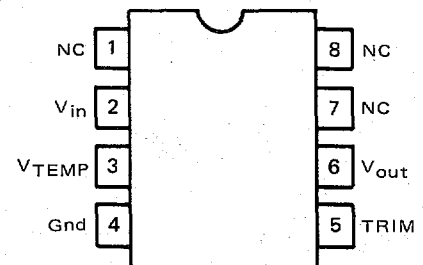
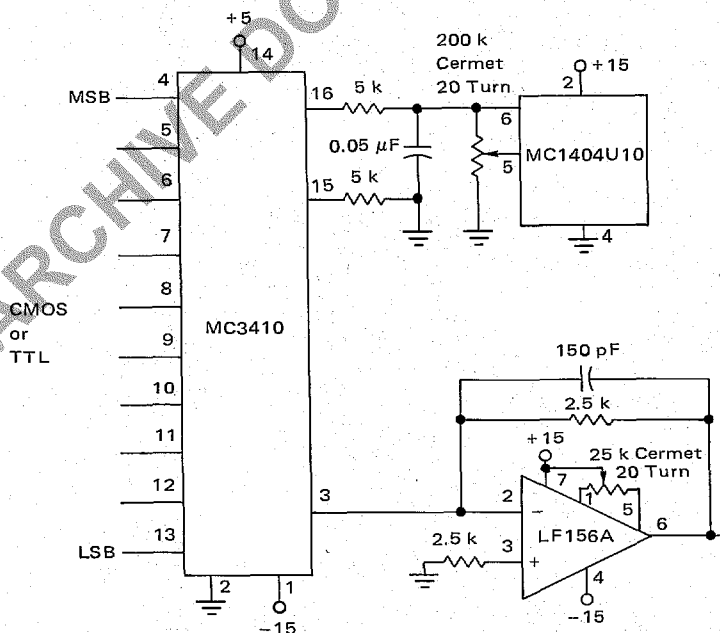

FIGURE 1 - VOLTAGE OUTPUT 10 BIT DAC USING MC1404U10



#### ORDERING INFORMATION

##### PACKAGE (ALL TYPES)

Ceramic DIP

Device	Temperature Range
--------	-------------------

##### 5.0 Volts

MC1504U5	-55°C to +125°C
MC1504AU5	-55°C to +125°C
MC1404U5	0°C to +70°C
MC1404AU5	0°C to +70°C

##### 6.25 Volts

MC1504U6	-55°C to +125°C
MC1504AU6	-55°C to +125°C
MC1404U6	0°C to +70°C
MC1404AU6	0°C to +70°C

##### 10 Volts

MC1504U10	-55°C to +125°C
MC1504AU10	-55°C to +125°C
MC1404U10	0°C to +70°C
MC1404AU10	0°C to +70°C



**ELECTRICAL CHARACTERISTICS** ( $V_{in} = 15$  Volts,  $T_A = 25^\circ\text{C}$  and Trim Terminal not connected unless otherwise noted)

Characteristic	Symbol	MC1404, A			MC1504, A			Unit
		Min	Typ	Max	Min	Typ	Max	
Output Voltage ( $I_o = 0$ mA)	$V_o$							Volt
U5, AU5		4.95	5.00	5.05	4.95	5.00	5.05	
U6, AU6		6.19	6.25	6.31	6.19	6.25	6.31	
U10, AU10		9.90	10	10.10	9.90	10	10.10	
Output Voltage Tolerance	—	—	$\pm 0.1$	$\pm 1.0$	—	$\pm 0.1$	$\pm 1.0$	%
Output Trim Range (Figure 10) ( $R_p = 100$ k $\Omega$ )	$\Delta V_{TRIM}$	$\pm 6.0$	—	—	$\pm 6.0$	—	—	%
Output Voltage Temperature Coefficient, Over Full Temperature Range	$\Delta V_o / \Delta T$							ppm/ $^\circ\text{C}$
MC1404, MC1504		—	10	40	—	—	55	
MC1404A, MC1504A		—	10	25	—	—	25	
Maximum Output Voltage Change Over Temperature Range	$\Delta V_o$							mV
MC1404U5, MC1504U5		—	—	14	—	—	50	
MC1404AU5, MC1504AU5		—	—	9.0	—	—	23	
MC1404U6, MC1504U6		—	—	17.5	—	—	62	
MC1404AU6, MC1504AU6		—	—	11	—	—	28	
MC1404U10, MC1504U10		—	—	28	—	—	99	
MC1404AU10, MC1504AU10		—	—	18	—	—	45	
Line Regulation (1) ( $V_{in} = V_{out} + 2.5$ V to 40 V, $I_{out} = 0$ mA)	Reg <sub>LINE</sub>	—	2.0	6.0	—	2.0	6.0	mV
Load Regulation (1) ( $0 \leq I_o \leq 10$ mA)	Reg <sub>LOAD</sub>	—	—	10	—	—	10	mV
Quiescent Current ( $I_o = 0$ mA)	$I_Q$	—	1.2	1.5	—	1.2	1.5	mA
Short Circuit Current	$I_{SC}$	15	20	30	—	—	30	mA
Long Term Stability	—	—	25	—	—	25	—	ppm/1000 hrs

Note 1: Includes thermal effects.

**DYNAMIC CHARACTERISTICS** ( $V_{in} = 15$  V,  $T_A = 25^\circ\text{C}$  all voltage ranges unless otherwise noted)

Characteristic	Symbol	MC1404, A			MC1504, A			Unit
		Min	Typ	Max	Min	Typ	Max	
Turn-On Settling Time (to $\pm 0.01\%$ )	$t_S$	—	50	—	—	50	—	$\mu\text{s}$
Output Noise Voltage — P to P (Bandwidth 0.1 to 10 Hz)	$e_n$	—	12	—	—	12	—	$\mu\text{V}$
Small-Signal Output Impedance 120 Hz	$r_o$	—	0.15	—	—	0.15	—	$\Omega$
500 Hz		—	0.2	—	—	0.2	—	
Power Supply Rejection Ratio	PSRR	70	80	—	70	80	—	dB







FIGURE 13 — 5.0 V, 6.0 AMP, 25 kHz SWITCHING REGULATOR WITH SEPARATE ULTRA-STABLE REFERENCE

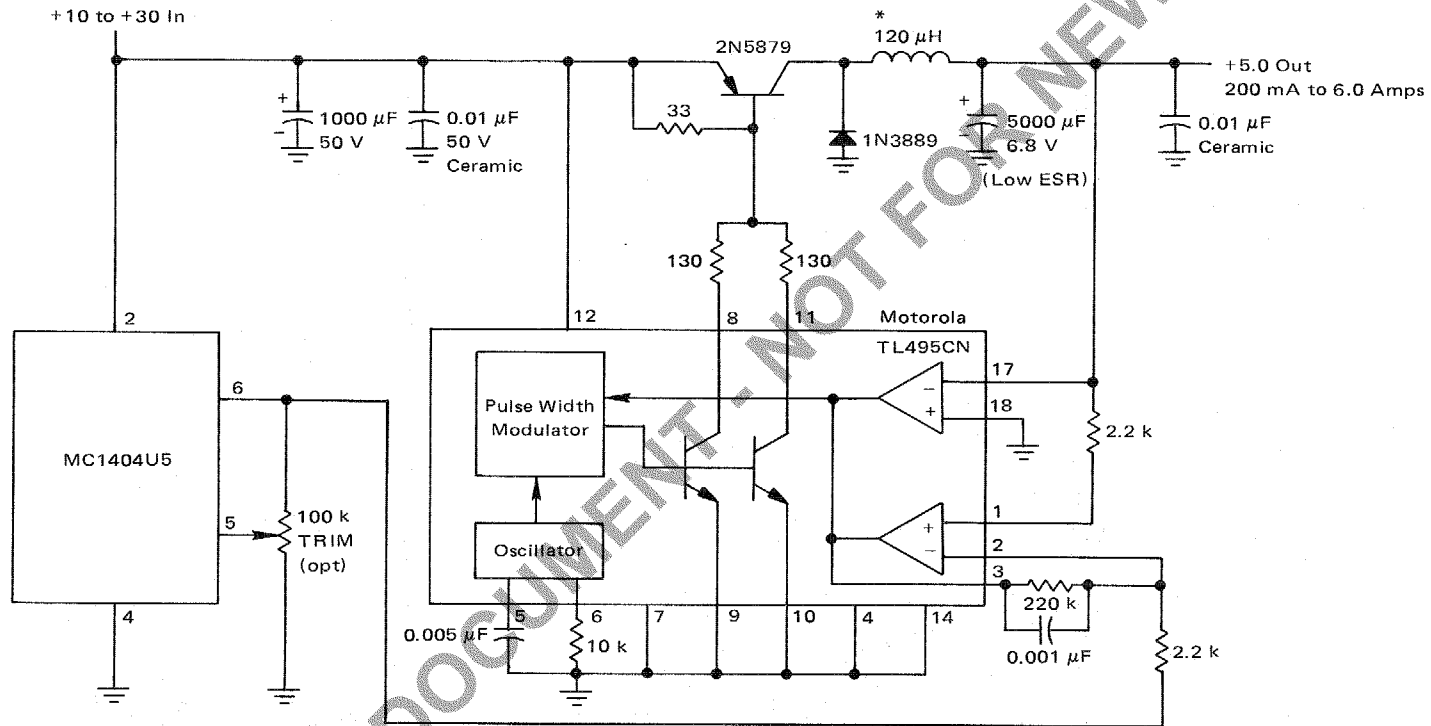

\* 40 Turns #16 Wire, Arnold A-894075-2 Ferrite Core

ARCHIVE DOCUMENT - NOT FOR NEW DESIGN

FIGURE 8 – SHORT CIRCUIT CURRENT versus TEMPERATURE

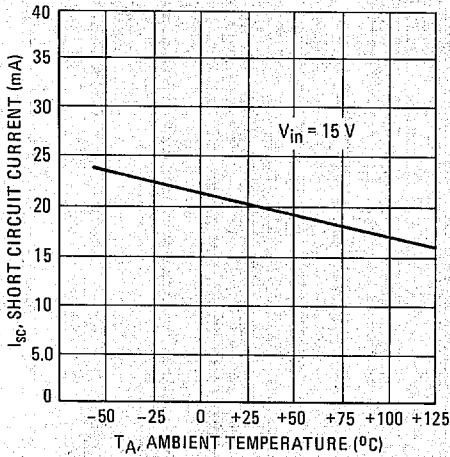

FIGURE 9 – V<sub>TEMP</sub> OUTPUT versus TEMPERATURE

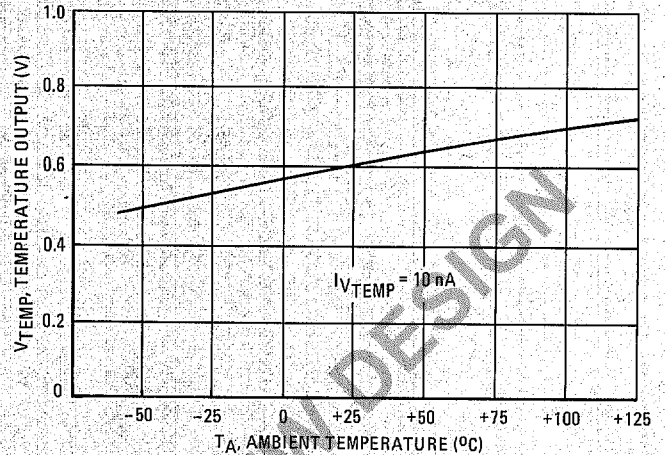
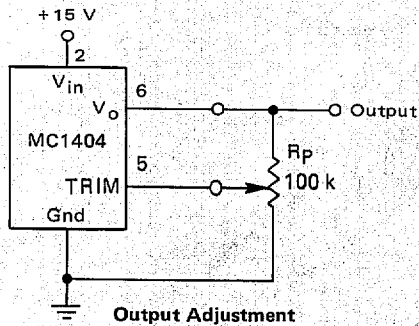
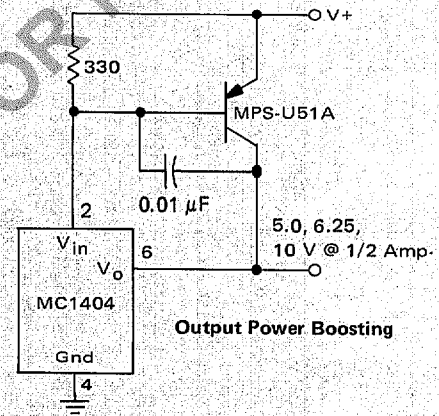

FIGURE 10 – OUTPUT TRIM CONFIGURATION



The MC1404 trim terminal can be used to adjust the output voltage over a ±6% range. For example, the output can be set to 10.000 V or to 10.240 V for binary applications. For trimming, Bourns type 3059, 100 kΩ or 200 kΩ trimpot is recommended.

FIGURE 11 – PRECISION SUPPLY USING MC1404



The addition of a power transistor, a resistor, and a capacitor converts the MC1404 into a precision supply with one ampere current capability. At V<sub>+</sub> = 15 V, the MC1404 can carry in excess of 14 mA of load current with good regulation. If the power transistor current gain exceeds 75, a one ampere supply can be realized.

FIGURE 12 – ULTRA STABLE REFERENCE FOR MC1723 VOLTAGE REGULATOR

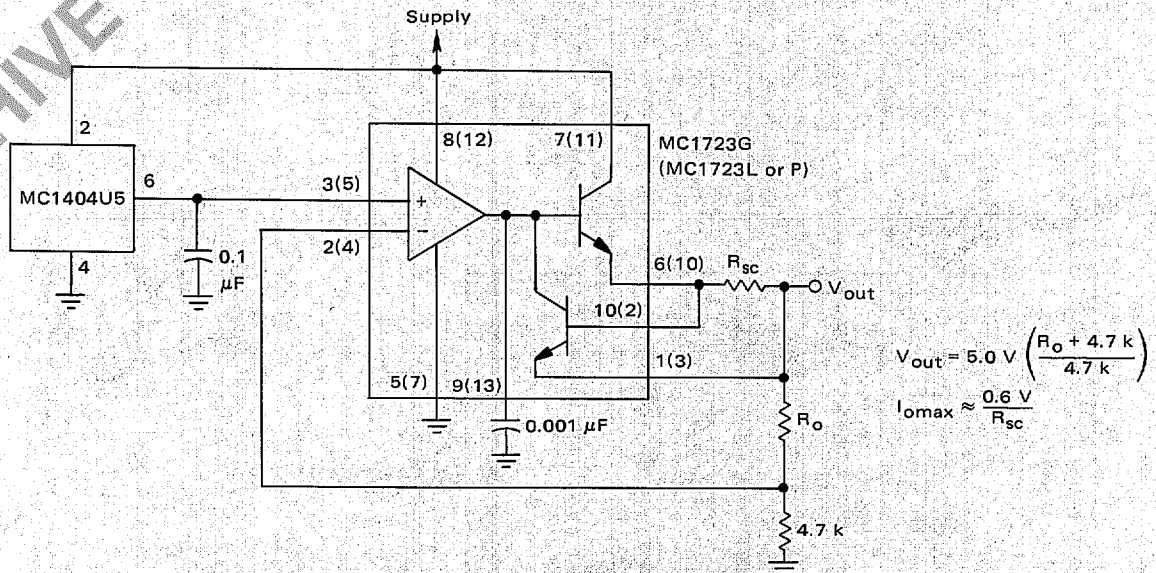

FIGURE 2 – SIMPLIFIED DEVICE DIAGRAM

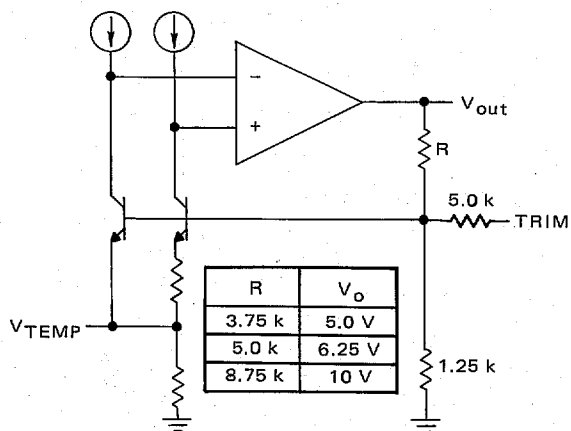

FIGURE 3 – LINE REGULATION versus TEMPERATURE

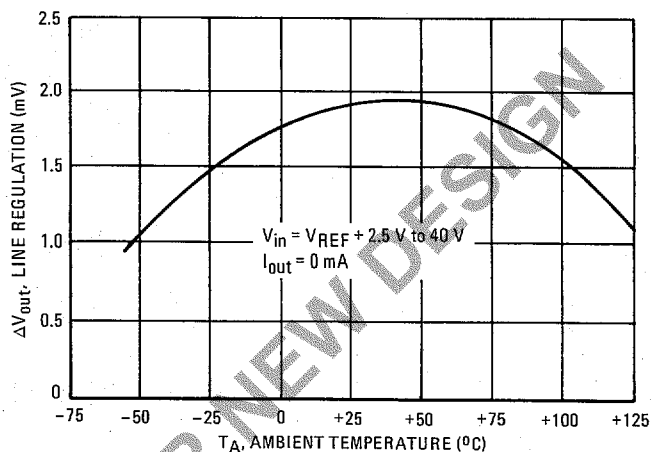

FIGURE 4 – OUTPUT VOLTAGE versus TEMPERATURE  
MC1404U10

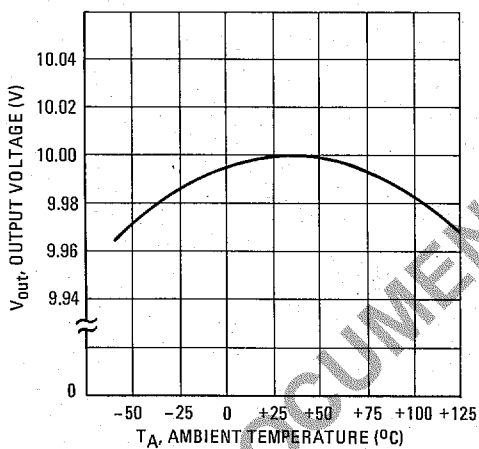

FIGURE 5 – LOAD REGULATION versus TEMPERATURE

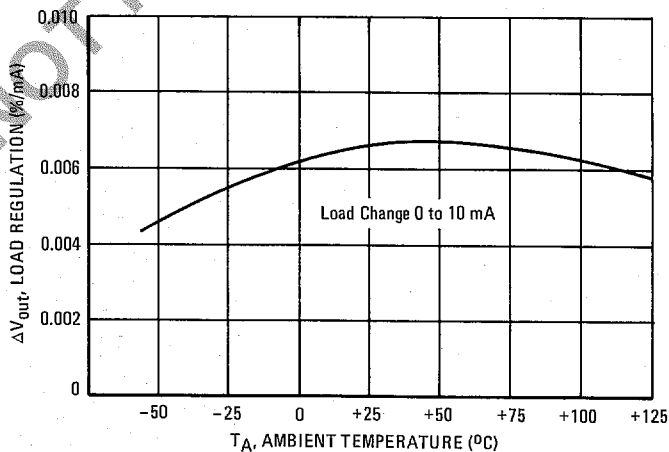

FIGURE 6 – POWER SUPPLY REJECTION RATIO  
versus FREQUENCY

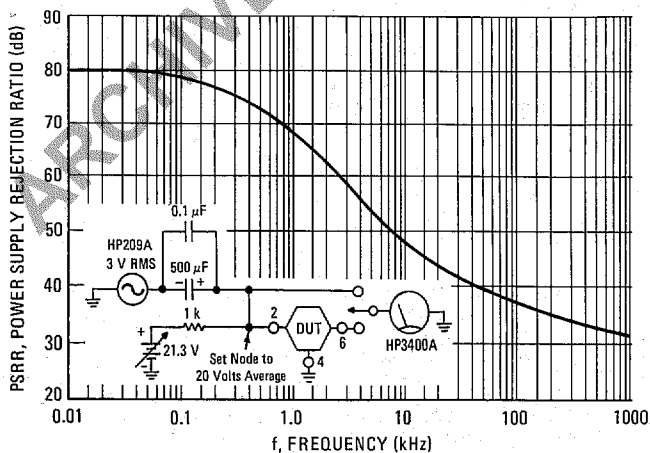

FIGURE 7 – QUIESCENT CURRENT versus TEMPERATURE

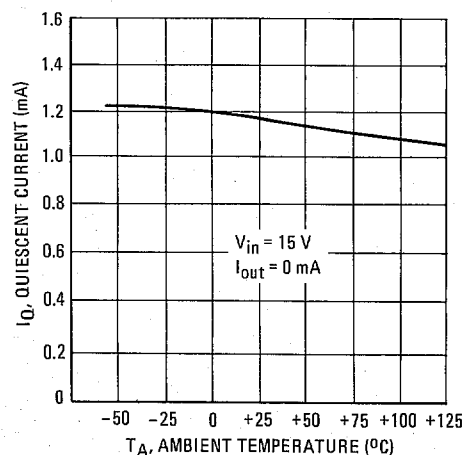
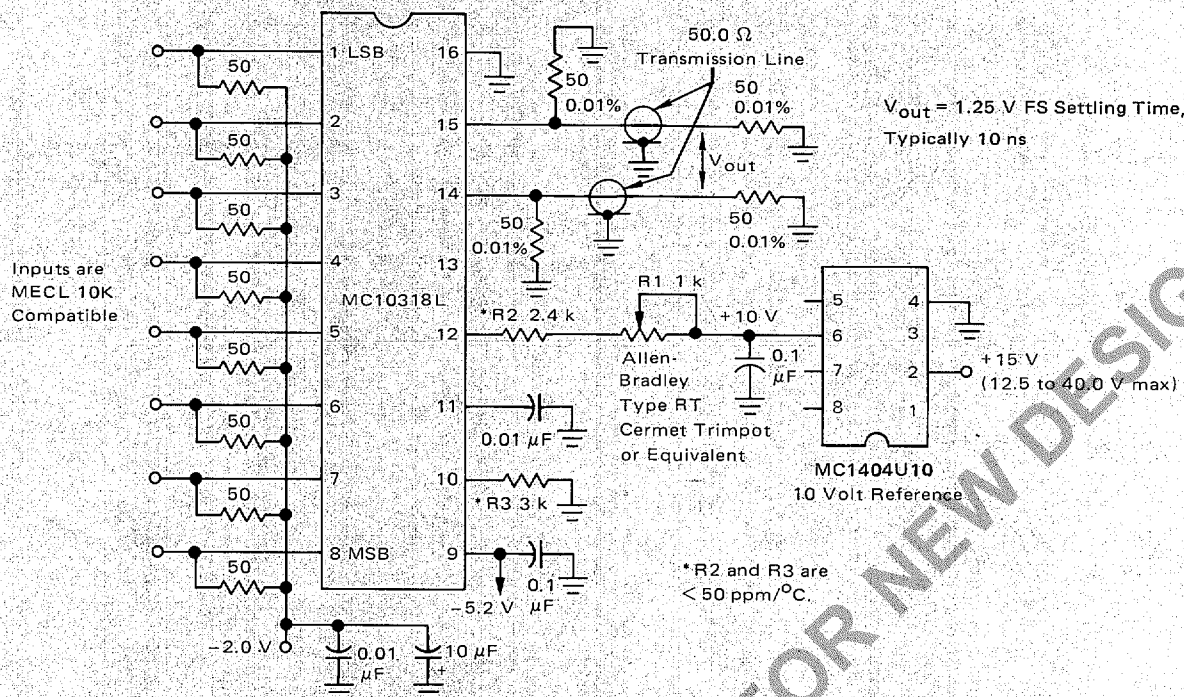
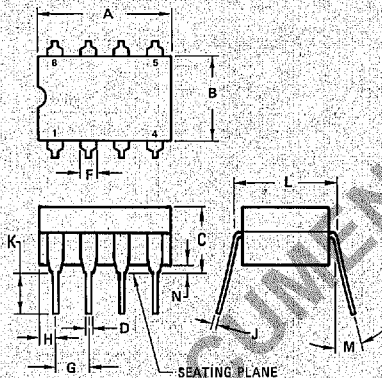

FIGURE 14 — HIGH SPEED 8-BIT D/A CONVERTER USING MC1404U10

$I_{FS}$  is set to 51.000 mA with R1



OUTLINE DIMENSIONS



DIM	MILLIMETERS		INCHES	
	MIN	MAX	MIN	MAX
A	9.91	10.92	0.390	0.430
B	6.22	6.99	0.245	0.275
C	4.32	5.08	0.170	0.200
D	0.41	0.51	0.016	0.020
E	1.40	1.65	0.055	0.065
F	2.54 BSC		0.100 BSC	
H	1.14	1.65	0.045	0.065
J	0.20	0.30	0.008	0.012
K	3.18	4.06	0.125	0.160
L	7.37	7.87	0.290	0.310
M	15°		15°	
N	0.51	1.02	0.020	0.040

- NOTES:
- LEADS WITHIN 0.13 mm (0.005) RAD OF TRUE POSITION AT SEATING PLANE AT MAXIMUM MATERIAL CONDITION.
  - DIMENSION "L" TO CENTER OF LEADS WHEN FORMED PARALLEL.

$\theta_{JA} = 130^{\circ}\text{C}/\text{W}$

CASE 693

THERMAL INFORMATION

The maximum power consumption an integrated circuit can tolerate at a given operating ambient temperature, can be found from the equation:

$$P_{D(T_A)} = \frac{T_{J(max)} - T_A}{R_{\theta JA} (Typ)}$$

Where:  $P_{D(T_A)}$  = Power Dissipation allowable at a given operating ambient temperature. This must be greater than the sum of the products of the supply

voltages and supply currents at the worst-case operating condition.

$T_{J(max)}$  = Maximum Operating Junction Temperature as listed in the Maximum Ratings Section

$T_A$  = Maximum Desired Operating Ambient Temperature

$R_{\theta JA}(Typ)$  = Typical Thermal Resistance Junction to Ambient

Motorola reserves the right to make changes to any products herein to improve reliability, function or design. Motorola does not assume any liability arising out of the application or use of any product or circuit described herein; neither does it convey any license under its patent rights nor the rights of others.



MOTOROLA Semiconductor Products Inc.

BOX 20912 • PHOENIX, ARIZONA 85036 • A SUBSIDIARY OF MOTOROLA INC.