

**MCM56824A**

**DSPRAM™**  
**8K x 24 Bit Fast Static RAM**

The MCM56824A is a 196,608 bit static random access memory organized as 8,192 words of 24 bits. The device integrates an 8K x 24 SRAM core with multiple chip enable inputs, output enable, and an externally controlled single address pin multiplexer. These functions allow for direct connection to the Motorola DSP56001 Digital Signal Processor and provide a very efficient means for implementation of a reduced parts count system requiring no additional interface logic.

The availability of multiple chip enable (E1 and E2) and output enable (G) inputs provides for greater system flexibility when multiple devices are used. With either chip enable input unasserted, the device will enter standby mode, useful in low-power applications. A single on-chip multiplexer selects A12 or X/Y as the highest order address input depending upon the state of the V/S control input. This feature allows one physical static RAM component to efficiently store program and vector or scalar operands by dynamically re-partitioning the RAM array. Typical applications will logically map vector operands into upper memory with scalar operands being stored in lower memory. By connecting DSP56001 address A15 to the VECTOR/SCALAR (V/S) MUX control pin, such partitioning can occur with no additional components. This allows efficient utilization of the RAM resource irrespective of operand type. See application diagrams at the end of this document for additional information.

Multiple power and ground pins have been utilized to minimize effects induced by output noise.

The MCM56824A is available in a 52 pin plastic leaded chip-carrier (PLCC) and a 9 x 10 grid, 86 bump surface mount PBGA.

- Single 5 V ± 10% Power Supply
- Fast Access and Cycle Times: 20/25/35 ns Max
- Fully Static Read and Write Operations
- Equal Address and Chip Enable Access Times
- Single Bit On-Chip Address Multiplexer
- Active High and Active Low Chip Enable Inputs
- Output Enable Controlled Three State Outputs
- High Board Density PLCC Package
- Low Power Standby Mode
- Fully TTL Compatible

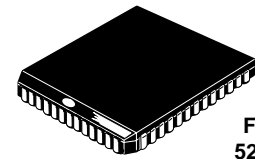

**FN PACKAGE**  
**52-LEAD PLCC**  
**CASE 778-02**

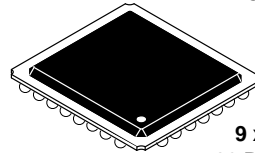

**9 x 10 GRID**  
**86 BUMP PBGA**  
**CASE 896A-01**

**PIN ASSIGNMENTS**  
**PLCC**

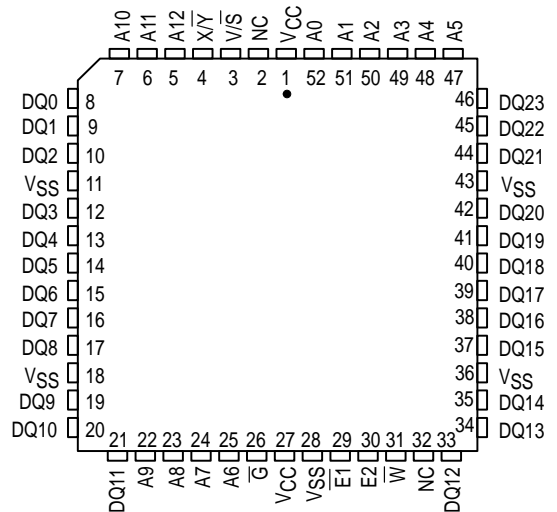

**VIEW OF PBGA PACKAGE BOTTOM**

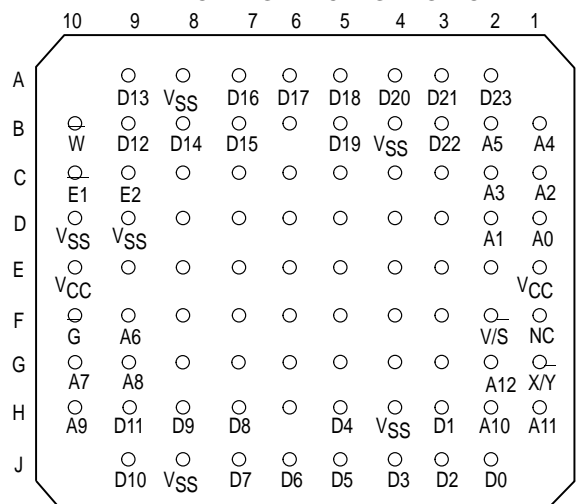

Not to Scale

PIN NAMES	
A0 – A11	Address Inputs
A12, X/Y	Multiplexed Address
V/S	Address Multiplexer Control
W	Write Enable
E1, E2	Chip Enable
G	Output Enable
DQ0 – DQ23	Data Input/Output
VCC	+5 V Power Supply
VSS	Ground
NC	No Connection

For proper operation of the device, all VSS pins must be connected to ground.

DSPRAM is a trademark of Motorola, Inc.

REV 2  
4/95

## BLOCK DIAGRAM

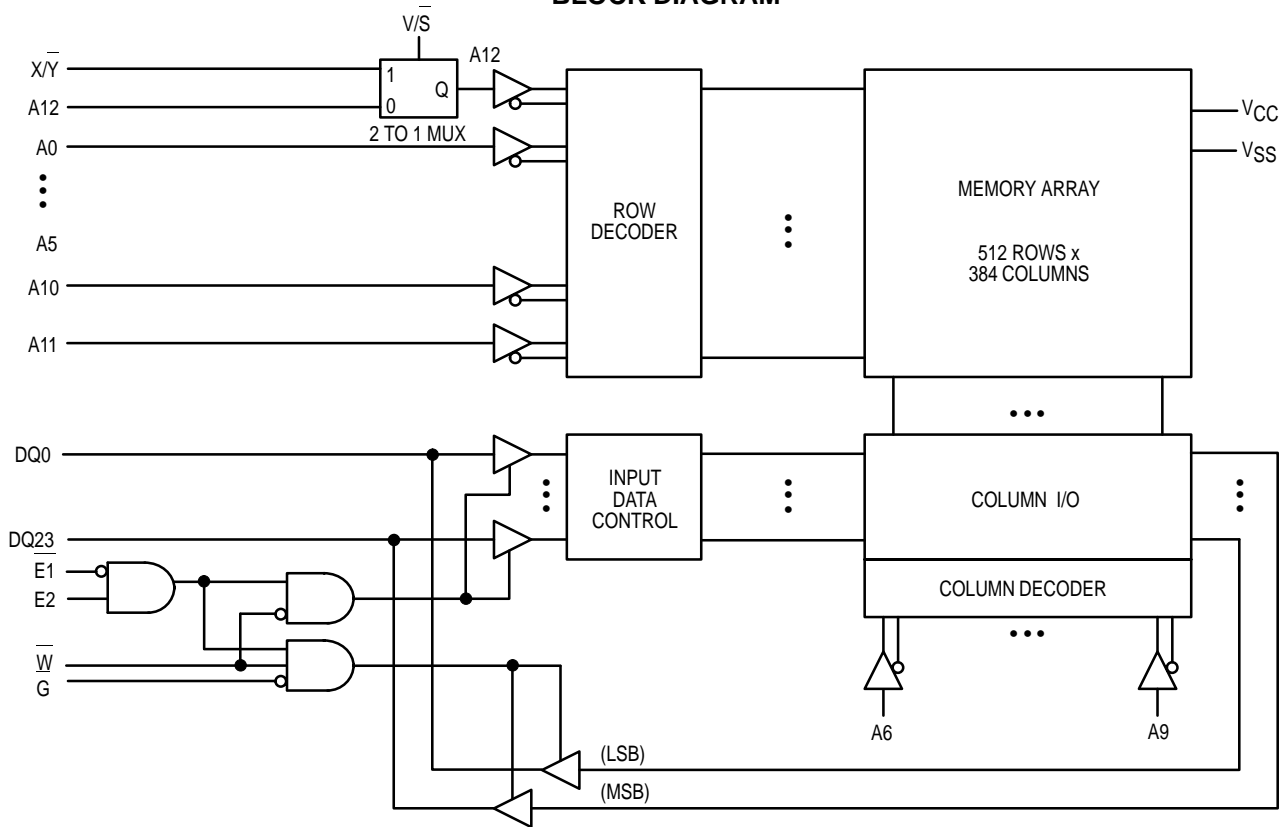

## TRUTH TABLE

$\overline{E1}$	$E2$	$\overline{G}$	$\overline{W}$	$\overline{V/S}$	Mode	Supply Current	I/O Status
H	X	X	X	X	Not Selected	$I_{SB}$	High-Z
X	L	X	X	X	Not Selected	$I_{SB}$	High-Z
L	H	H	H	X	Output Disable	$I_{CC}$	High-Z
L	H	L	H	H	Read Using X/Y	$I_{CC}$	Data Out
L	H	L	H	L	Read Using A12	$I_{CC}$	Data Out
L	H	X	L	H	Write Using X/Y	$I_{CC}$	Data In
L	H	X	L	L	Write Using A12	$I_{CC}$	Data In

NOTE: X=don't care.

## ABSOLUTE MAXIMUM RATINGS (Voltages Referenced to $V_{SS} = 0$ V)

Rating	Symbol	Value	Unit
Power Supply Voltage	$V_{CC}$	-0.5 to +7.0	V
Voltage Relative to $V_{SS}$ for Any Pin Except $V_{CC}$	$V_{in}, V_{out}$	-0.5 to $V_{CC} + 0.5$	V
Output Current (per I/O)	$I_{out}$	$\pm 20$	mA
Power Dissipation	$P_D$	1.75	W
Temperature Under Bias	$T_{bias}$	-10 to +85	$^{\circ}C$
Operating Temperature	$T_A$	0 to +70	$^{\circ}C$
Storage Temperature	$T_{stg}$	-55 to +125	$^{\circ}C$

NOTE: Permanent device damage may occur if ABSOLUTE MAXIMUM RATINGS are exceeded. Functional operation should be restricted to RECOMMENDED OPERATING CONDITIONS. Exposure to higher than recommended voltages for extended periods of time could affect device reliability.

This device contains circuitry to protect against damage due to high static voltages or electric fields; however, it is advised that normal precautions be taken to avoid application of any voltage higher than maximum rated voltages to this high-impedance circuit.

This CMOS memory circuit has been designed to meet the dc and ac specifications shown in the tables, after thermal equilibrium has been established. The circuit is assumed to be in a test socket or mounted on a printed circuit board with at least 300 LFPM of transverse air flow being maintained.

## DC OPERATING CONDITIONS AND CHARACTERISTICS

( $V_{CC} = 5.0 \text{ V} \pm 10\%$ ,  $T_A = 0 \text{ to } +70^\circ\text{C}$ , Unless Otherwise Noted)

### RECOMMENDED OPERATING CONDITIONS (Voltages Referenced to $V_{SS} = 0 \text{ V}$ )

Parameter	Symbol	Min	Typ	Max	Unit
Supply Voltage (Operating Voltage Range)	$V_{CC}$	4.5	5.0	5.5	V
Input High Voltage	$V_{IH}$	2.2	—	$V_{CC} + 0.3$	V
Input Low Voltage	$V_{IL}$	-0.5*	—	0.8	V

\*  $V_{IL}(\text{min}) = -3.0 \text{ V ac}$  (pulse width  $\leq 20 \text{ ns}$ )

### DC CHARACTERISTICS

Parameter	Symbol	Min	Max	Unit
Input Leakage Current (All Inputs, $V_{in} = 0 \text{ to } V_{CC}$ )	$I_{lkg(i)}$	—	$\pm 1.0$	$\mu\text{A}$
Output Leakage Current ( $G = V_{IH}$ , $E1 = V_{IH}$ , $E2 = V_{IL}$ , $V_{out} = 0 \text{ to } V_{CC}$ )	$I_{lkg(O)}$	—	$\pm 1.0$	$\mu\text{A}$
AC Supply Current ( $G = V_{IH}$ , $E1 = V_{IL}$ , $E2 = V_{IH}$ , $I_{out} = 0 \text{ mA}$ , All Other Inputs $\geq V_{IL} = 0.0 \text{ V}$ and $V_{IH} \geq 3.0 \text{ V}$ )	$I_{CCA}$	—	260 220 180	mA
MCM56824A-20 Cycle Time: $\geq 20 \text{ ns}$				
MCM56824A-25 Cycle Time: $\geq 25 \text{ ns}$				
MCM56824A-35 Cycle Time: $\geq 35 \text{ ns}$				
Standby Current ( $E1 = V_{IH}$ , $E2 = V_{IL}$ , All Inputs = $V_{IL}$ or $V_{IH}$ )	$I_{SB1}$	—	15	mA
CMOS Standby Current ( $E1 \geq V_{CC} - 0.2 \text{ V}$ , $E2 \leq 0.2 \text{ V}$ , All Inputs $\geq V_{CC} - 0.2 \text{ V}$ or $\leq 0.2 \text{ V}$ )	$I_{SB2}$	—	10	mA
Output Low Voltage ( $I_{OL} = +8.0 \text{ mA}$ )	$V_{OL}$	—	0.4	V
Output High Voltage ( $I_{OH} = -4.0 \text{ mA}$ )	$V_{OH}$	2.4	—	V

### CAPACITANCE ( $f = 1.0 \text{ MHz}$ , $dV = 3.0 \text{ V}$ , $T_A = 25^\circ\text{C}$ , Periodically Sampled Rather Than 100% Tested)

Parameter	Symbol	Typ	Max	Unit
Input Capacitance All Pins Except DQ0 – DQ23	$C_{in}$	4	6	pF
Input/Output Capacitance DQ0 – DQ23	$C_{out}$	6	8	pF

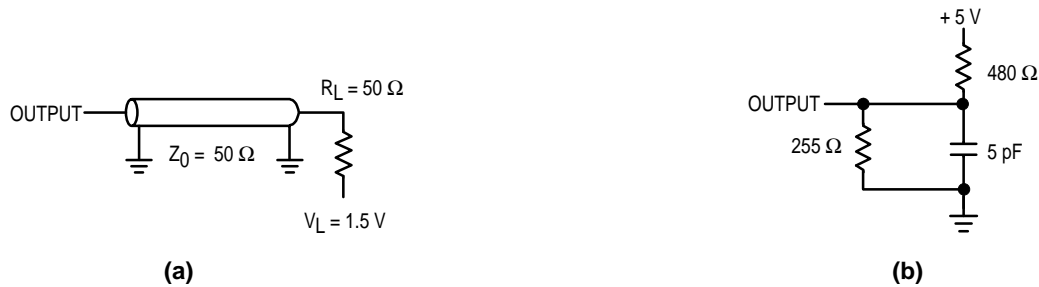

Figure 1. AC Test Loads

## AC OPERATING CONDITIONS AND CHARACTERISTICS

( $V_{CC} = 5.0\text{ V} \pm 10\%$ ,  $T_A = 0\text{ to } +70^\circ\text{C}$ , Unless Otherwise Noted)

Input Timing Measurement Reference Level ..... 1.5 V  
 Input Pulse Levels ..... 0 to 3.0 V  
 Input Rise/Fall Time ..... 3 ns

Output Timing Reference Level ..... 1.5 V  
 Output Load ..... See Figure 1a Unless Otherwise Noted

### READ CYCLE TIMING (See Notes 1, 2, and 3)

Parameter	Symbol	MCM56824A-20		MCM56824A-25		MCM56824A-35		Unit	Notes
		Min	Max	Min	Max	Min	Max		
Read Cycle Time	$t_{AVAV}$	20	—	25	—	35	—	ns	
Address Access Time	$t_{AVQV}$	—	20	—	25	—	35	ns	
MUX Control Valid to Output Valid	$t_{VSVQV}$	—	20	—	25	—	35	ns	
Chip Enable to Output Valid	$t_{E1LQV}$ $t_{E2HQV}$	—	20	—	25	—	35	ns	4
Output Enable to Output Valid	$t_{GLQV}$	—	8	—	10	—	15	ns	
Output Active from Chip Enable	$t_{E1LQX}$ $t_{E2HQX}$	2	—	2	—	0	—	ns	4, 5
Output Active from Output Enable	$t_{GLQX}$	0	—	0	—	0	—	ns	5
Output Hold from Address Change	$t_{AXQX}$	4	—	5	—	5	—	ns	
Output Hold from MUX Control Change	$t_{VXQX}$	4	—	5	—	5	—	ns	
Chip Enable to Output High-Z	$t_{E1HQZ}$ $t_{E2LQZ}$	0	10	0	15	0	15	ns	4, 5
Output Enable High to Output High-Z	$t_{GHQZ}$	0	8	0	15	0	15	ns	5

#### NOTES:

1. A read cycle is defined by  $\bar{W}$  high.
2. All read cycle timings are referenced from the last valid address or vector/scalar transition to the first address or vector/scalar transition.
3. Addresses valid prior to or coincident with  $\bar{E}1$  going low or  $\bar{E}2$  going high.
4.  $\bar{E}1$  in the timing diagrams represents both  $\bar{E}1$  and  $\bar{E}2$  with  $\bar{E}1$  asserted low and  $\bar{E}2$  asserted high.
5. Transition is measured  $\pm 500\text{ mV}$  from steady-state voltage with load of Figure 1b. This parameter is sampled and not 100% tested. At any given voltage and temperature,  $t_{E1HQZ}\text{ max}$  is less than  $t_{E1LQX}\text{ min}$ ,  $t_{E2LQZ}\text{ max}$  is less than  $t_{E2HQX}\text{ min}$ , and  $t_{GHQZ}\text{ max}$  is less than  $t_{GLQX}\text{ min}$  for a given device and from device to device.

### READ CYCLE

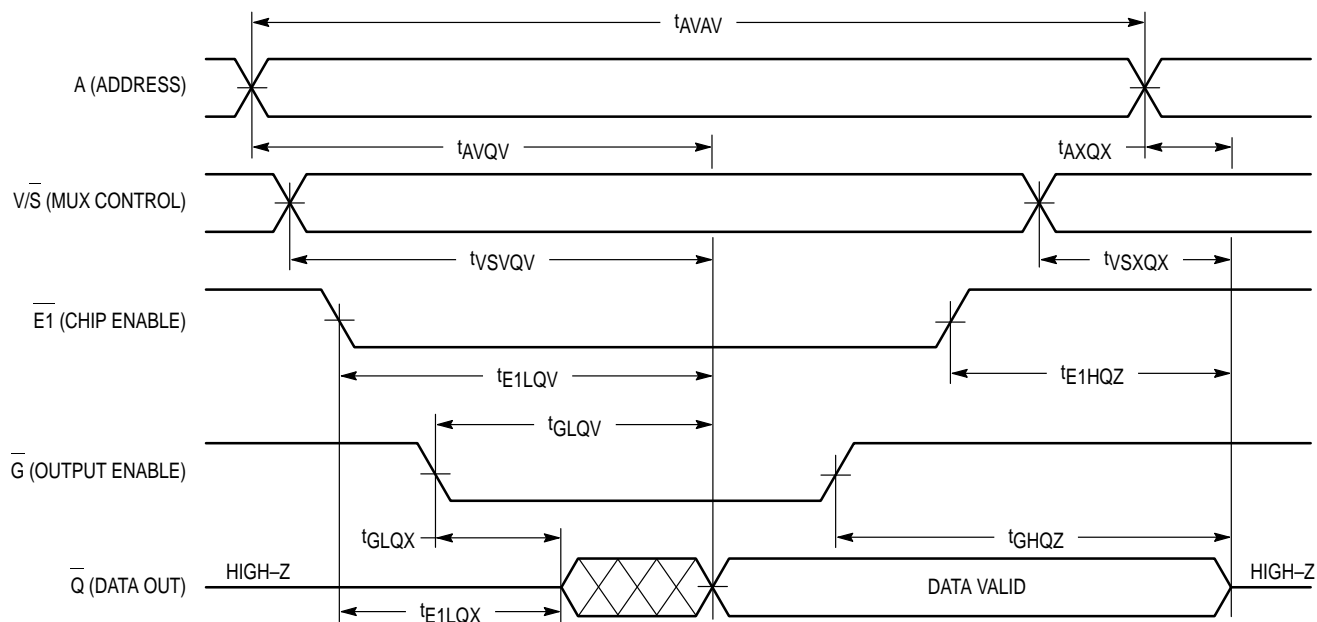

**WRITE CYCLE TIMING** (Write Enable Initiated, See Note 1)

Parameter	Symbol	MCM56824A-20		MCM56824A-25		MCM56824A-35		Unit	Notes
		Min	Max	Min	Max	Min	Max		
Write Cycle Time	$t_{AVAV}$	20	—	25	—	35	—	ns	
Address Setup Time	$t_{AVWL}$	0	—	0	—	0	—	ns	2
MUX Control Setup Time	$t_{VSVWL}$	0	—	0	—	0	—	ns	
Address Valid to End of Write	$t_{AVWH}$	15	—	20	—	30	—	ns	
MUX Control Valid to End of Write	$t_{VSVWH}$	15	—	20	—	30	—	ns	
Write Pulse Width	$t_{WLWH}$	15	—	15	—	20	—	ns	3
Write Enable to Chip Enable Disable	$t_{WLE1H}$ $t_{WLE2L}$	15	—	15	—	20	—	ns	3, 4
Chip Enable to End of Write	$t_{E1LWH}$ $t_{E2HWH}$	15	—	15	—	20	—	ns	3, 4
Data Valid to End of Write	$t_{DVWH}$	8	—	10	—	15	—	ns	
Data Hold Time	$t_{WHDX}$	0	—	0	—	0	—	ns	5
Write Recovery Time	$t_{WHAX}$	0	—	0	—	0	—	ns	2
MUX Control Recovery Time	$t_{WHVSX}$	0	—	0	—	0	—	ns	
Write High to Output Low-Z	$t_{WHQX}$	4	—	5	—	5	—	ns	6
Write Low to Output High-Z	$t_{WLQZ}$	0	15	0	15	0	15	ns	6

**NOTES:**

1. A write cycle starts at the latest transition of  $\overline{E1}$  low,  $\overline{W}$  low, or E2 high. A write cycle ends at the earliest transition of  $\overline{E1}$  high,  $\overline{W}$  high, or E2 low.
2. Write must be high for all address transitions.
3. If  $\overline{W}$  goes low coincident with or prior to  $\overline{E1}$  low or E2 high the outputs will remain in a high-impedance state.
4. E1 in the timing diagrams represents both E1 and E2 with E1 asserted low and E2 asserted high.
5. During this time the output pins may be in the output state. Signals of opposite phase must not be applied to the outputs at this time.
6. Transition is measured  $\pm 500$  mV from steady-state voltage with load of Figure 1b. This parameter is sampled and not 100% tested. At any given voltage and temperature,  $t_{E1HQZ}$  max is less than  $t_{E1LQX}$  min,  $t_{E2LQZ}$  max is less than  $t_{E2HQX}$  min, and  $t_{GHQZ}$  max is less than  $t_{GLQX}$  min for a given device and from device to device.

**$\overline{WE}$  INITIATED WRITE CYCLE**

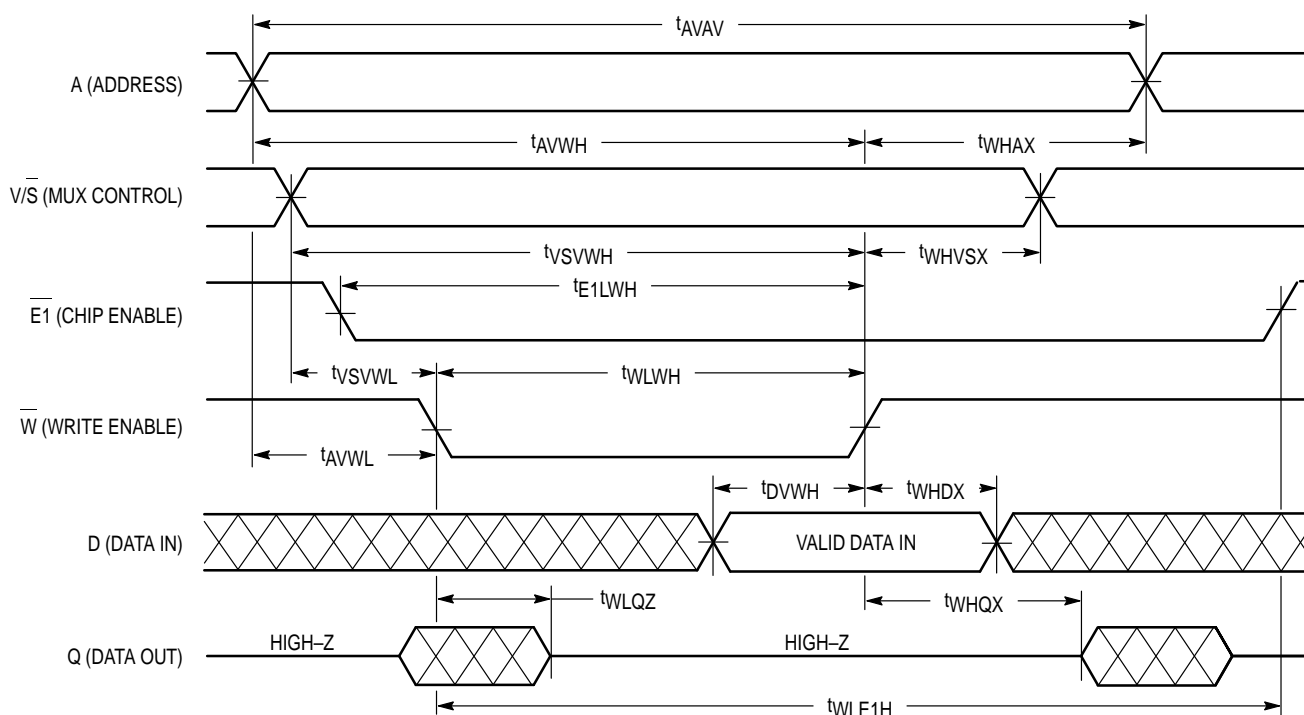

**WRITE CYCLE TIMING** (Chip Enable Initiated, See Note 1)

Parameter	Symbol	MCM56824A-20		MCM56824A-25		MCM56824A-35		Unit	Notes
		Min	Max	Min	Max	Min	Max		
Write Cycle Time	$t_{AVAV}$	20	—	25	—	35	—	ns	
Address Setup Time	$t_{AVE1L}$ $t_{AVE2H}$	0	—	0	—	0	—	ns	2
MUX Control Setup Time	$t_{VSVE1L}$ $t_{VSVE2H}$	0	—	0	—	0	—	ns	2
Address Valid to End of Write	$t_{AVE1H}$ $t_{AVE2L}$	15	—	20	—	30	—	ns	2
MUX Control Valid to End of Write	$t_{VSVE1H}$ $t_{VSVE2L}$	15	—	20	—	30	—	ns	2
Chip Enable to End of Write	$t_{E1LE1H}$ $t_{E2HE2L}$	12	—	15	—	20	—	ns	2, 3
Data Valid to End of Write	$t_{DVE1H}$ $t_{DVE2L}$	8	—	10	—	15	—	ns	2
Data Hold Time	$t_{E1HDX}$ $t_{E2LDX}$	0	—	0	—	0	—	ns	2, 4
Write Recovery Time	$t_{E1HAX}$ $t_{E2LAX}$	0	—	0	—	0	—	ns	2
MUX Control Recovery Time	$t_{E1HVSX}$ $t_{E2LVSX}$	0	—	0	—	0	—	ns	2

**NOTES:**

1. A write cycle starts at the latest transition of  $\overline{E1}$  low,  $\overline{W}$  low, or  $\overline{E2}$  high. A write cycle ends at the earliest transition of  $\overline{E1}$  high,  $\overline{W}$  high, or  $\overline{E2}$  low.
2.  $\overline{E1}$  in the timing diagrams represents both  $\overline{E1}$  and  $\overline{E2}$  with  $\overline{E1}$  asserted low and  $\overline{E2}$  asserted high.
3. If  $\overline{W}$  goes low coincident with or prior to  $\overline{E1}$  low or  $\overline{E2}$  high the outputs will remain in a high-impedance state.
4. During this time the output pins may be in the output state. Signals of opposite phase must not be applied to the outputs at this time.

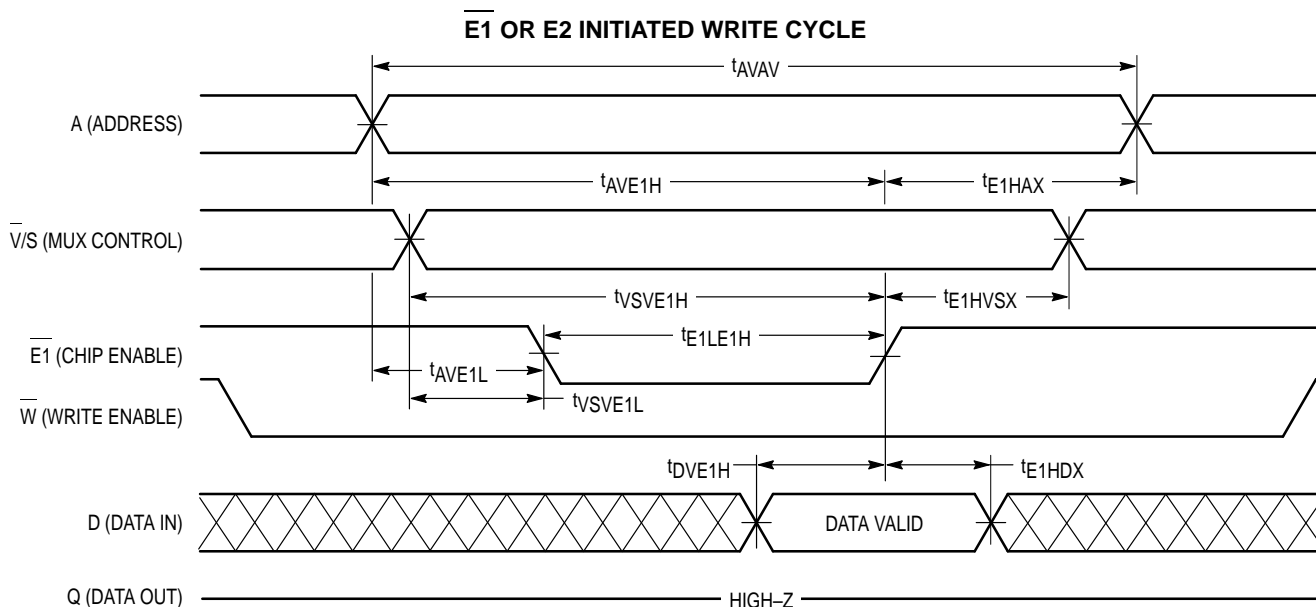

**DSPRAM Multiplexed Vector/Scalar Address Maps**

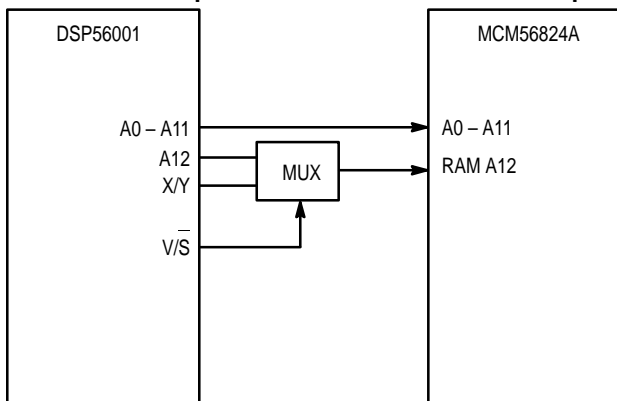

**8K x 24 DSPRAM Used in Typical Application**

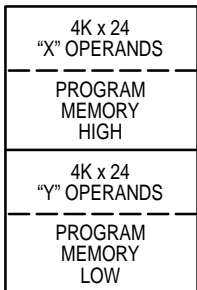
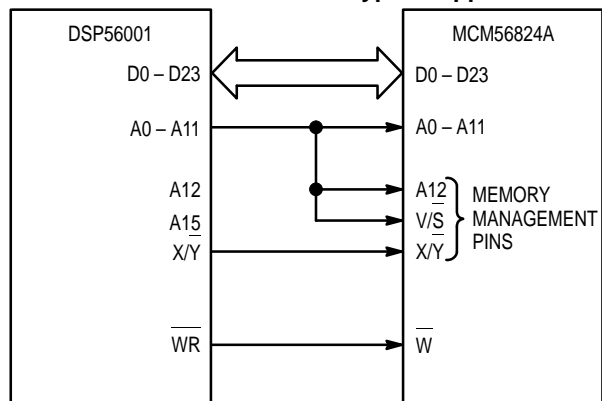

V/S = "1"

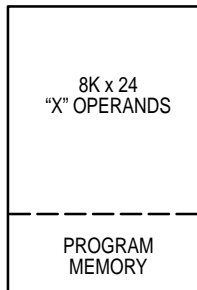

V/S = "0"

**ORDERING INFORMATION**  
(Order by Full Part Number)

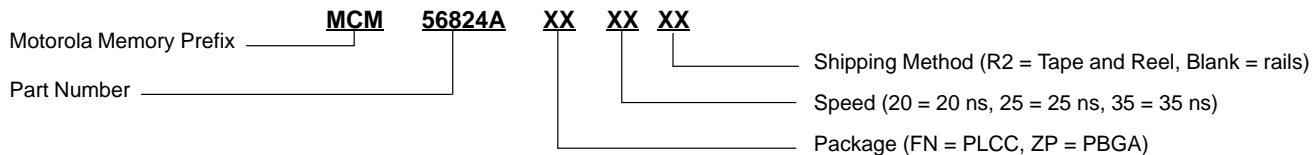

- Full Part Numbers — MCM56824AFN20 MCM56824AFN25 MCM56824AFN35  
 MCM56824AZP20 MCM56824AZP25 MCM56824AZP35  
 MCM56824AZP20R2 MCM56824AZP25R2 MCM56824AZP35R2

# PACKAGE DIMENSIONS

ZP PACKAGE  
9 x 10 PBGA  
CASE 896A-01

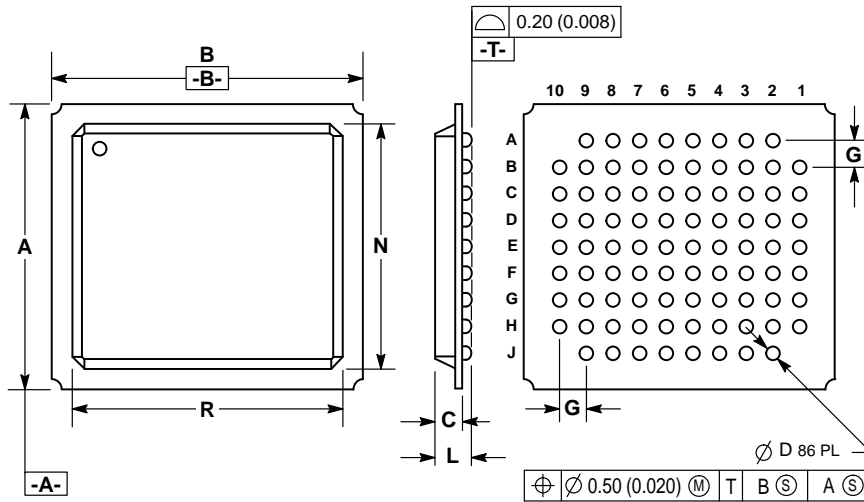

- NOTES:  
1. DIMENSIONING AND TOLERANCING PER ANSI Y14.5M, 1982.  
2. CONTROLLING DIMENSION: MILLIMETER.

DIM	MILLIMETERS		INCHES	
	MIN	MAX	MIN	MAX
A	16.16	16.36	0.637	0.644
B	17.68	17.88	0.697	0.703
C	1.33	1.73	0.053	0.068
D	0.69	0.81	0.028	0.031
G	1.524 BSC		0.060 BSC	
L	1.84	2.44	0.073	0.096
N	13.80	14.20	0.544	0.559
R	15.29	15.69	0.602	0.617



**FN PACKAGE  
52-LEAD PLCC  
CASE 778-02**

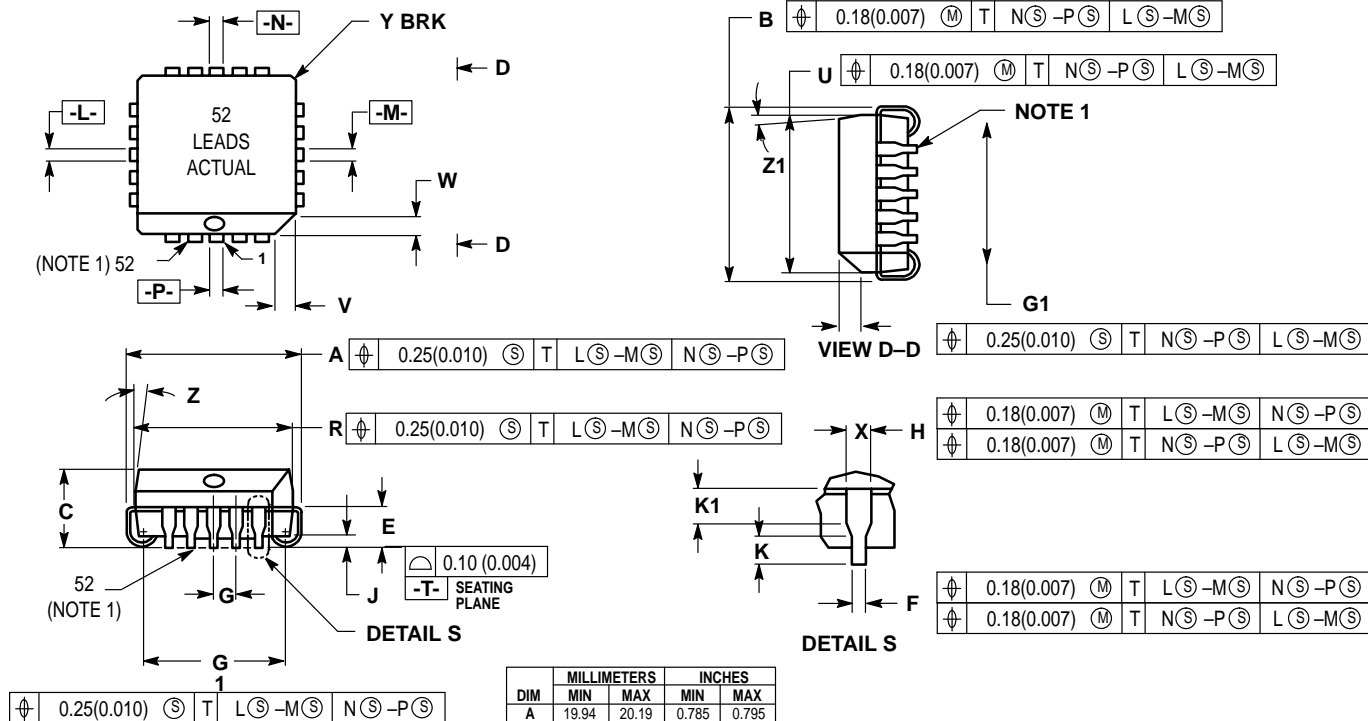

DIM	MILLIMETERS		INCHES	
	MIN	MAX	MIN	MAX
A	19.94	20.19	0.785	0.795
B	19.94	20.19	0.785	0.795
C	4.20	4.57	0.165	0.180
E	2.29	2.79	0.090	0.110
F	0.33	0.48	0.013	0.019
G	1.27 BSC		0.050 BSC	
H	0.66	0.81	0.026	0.032
J	0.51	—	0.020	—
K	0.64	—	0.025	—
R	19.05	19.20	0.750	0.756
U	19.05	19.20	0.750	0.756
V	1.07	1.21	0.042	0.048
W	1.07	1.21	0.042	0.048
X	1.07	1.42	0.042	0.056
Y	—	0.50	—	0.020
Z	2°	10°	2°	10°
G1	18.04	18.54	0.710	0.730
K1	1.02	—	0.040	—
Z1	2°	10°	2°	10°

- NOTES:
1. DUE TO SPACE LIMITATION, CASE 778-02 SHALL BE REPRESENTED BY A GENERAL (SMALLER) CASE OUTLINE DRAWING RATHER THAN SHOWING ALL 52 LEADS.
  2. DATUMS -L-, -M-, -N-, AND -P- DETERMINED WHERE TOP OF LEAD SHOULDER EXIT PLASTIC BODY AT MOLD PARTING LINE.
  3. DIM G1, TRUE POSITION TO BE MEASURED AT DATUM -T-, SEATING PLANE.
  4. DIM R AND U DO NOT INCLUDE MOLD PROTRUSION. ALLOWABLE MOLD PROTRUSION IS 0.25 (0.010) PER SIDE.
  5. DIMENSIONING AND TOLERANCING PER ANSI Y14.5M, 1982.
  6. CONTROLLING DIMENSION: INCH.

Motorola reserves the right to make changes without further notice to any products herein. Motorola makes no warranty, representation or guarantee regarding the suitability of its products for any particular purpose, nor does Motorola assume any liability arising out of the application or use of any product or circuit, and specifically disclaims any and all liability, including without limitation consequential or incidental damages. "Typical" parameters which may be provided in Motorola data sheets and/or specifications can and do vary in different applications and actual performance may vary over time. All operating parameters, including "Typicals" must be validated for each customer application by customer's technical experts. Motorola does not convey any license under its patent rights nor the rights of others. Motorola products are not designed, intended, or authorized for use as components in systems intended for surgical implant into the body, or other applications intended to support or sustain life, or for any other application in which the failure of the Motorola product could create a situation where personal injury or death may occur. Should Buyer purchase or use Motorola products for any such unintended or unauthorized application, Buyer shall indemnify and hold Motorola and its officers, employees, subsidiaries, affiliates, and distributors harmless against all claims, costs, damages, and expenses, and reasonable attorney fees arising out of, directly or indirectly, any claim of personal injury or death associated with such unintended or unauthorized use, even if such claim alleges that Motorola was negligent regarding the design or manufacture of the part. Motorola and  are registered trademarks of Motorola, Inc. Motorola, Inc. is an Equal Opportunity/Affirmative Action Employer.

Mfax is a trademark of Motorola, Inc.

**How to reach us:**

**USA/EUROPE/Locations Not Listed:** Motorola Literature Distribution;  
P.O. Box 5405, Denver, Colorado 80217. 303-675-2140 or 1-800-441-2447

**JAPAN:** Nippon Motorola Ltd.: SPD, Strategic Planning Office, 4-32-1,  
Nishi-Gotanda, Shinagawa-ku, Tokyo 141, Japan. 81-3-5487-8488

**Mfax™:** RMFAX0@email.sps.mot.com – TOUCHTONE 602-244-6609  
– US & Canada ONLY 1-800-774-1848

**ASIA/PACIFIC:** Motorola Semiconductors H.K. Ltd.; 8B Tai Ping Industrial Park,  
51 Ting Kok Road, Tai Po, N.T., Hong Kong. 852-26629298

**INTERNET:** <http://motorola.com/sps>

