

LM1946 Over/Under Current Limit Diagnostic Circuit

General Description

The LM1946 provides the industrial or automotive system designer with over or under current limit detection superior to that of ordinary transistor or comparator-based circuits.

Each of the five independent comparators can be used to monitor a separate load as either an over current or under current limit detector. Two comparators monitoring a single load can function as a current window monitor.

Current is sensed by monitoring the voltage drop across the wiring harness, pc board trace, or external sense resistor that feeds the load.

Provisions for compensating the user set limits for wiring harness resistance variations over temperature and supply voltage variations are also available.

When a limit is reached in one of the comparators, it turns on its output which can drive an external LED or microprocessor.

One side of the load can be grounded (not possible with ordinary comparator designs), which is important for automotive systems.

Features

- Five independent comparators
- Capable of 20 mA per output
- Low power drain
- User set input threshold voltages
- Reverse battery protection
- 60V load dump protection on supply and all inputs
- Input common mode range exceeds V_{CC}
- Short circuit protection
- Thermal overload protection
- Prove-out test pin
- Available in plastic DIP and SO packages

Applications

- Lamp fault detector
- Motor stall detector
- Power supply bus monitoring

Typical Application Circuit—Lamp Fault Detector ($I_L > 1A$)

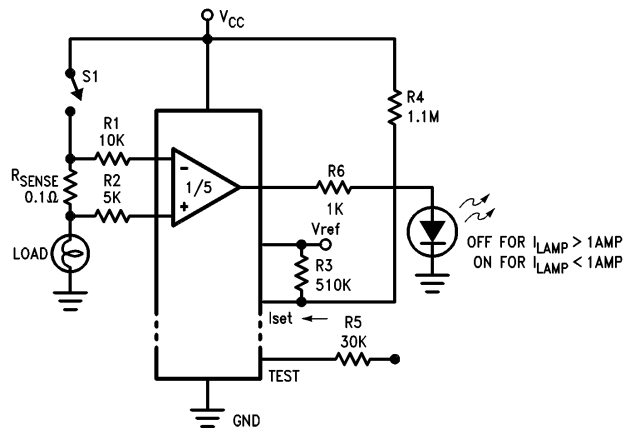

FIGURE 1

TL/H/8707-2

Absolute Maximum Ratings

If Military/Aerospace specified devices are required, please contact the National Semiconductor Sales Office/Distributors for availability and specifications.

Supply Voltage (V_{CC} and Input Pins)

Survival Voltage ($T \leq 100$ ms) $-50V$ to $+60V$

Operational Voltage $9V$ to $26V$

Internal Power Dissipation (Note 1) Internally Limited

Output Short Circuit to Ground or V_{CC}

Continuous

Operating Temperature Range (T_A)

-40°C to $+85^\circ\text{C}$

Maximum Junction Temperature

$+150^\circ\text{C}$

Storage Temperature Range

-65°C to $+150^\circ\text{C}$

Lead Temperature (Soldering, 10 sec.)

$+260^\circ\text{C}$

ESD Susceptibility (Note 3)

$600V$

Electrical Characteristics $9V \leq V_{CC} \leq 16V$, $I_{set} = 20 \mu\text{A}$, $T_j = 25^\circ\text{C}$ (unless otherwise specified)

Parameter	Conditions	Min	Typ	Max	Units
Quiescent Current	All Outputs "Off"		1.40	3.00	mA_{dc}
Reference Voltage	$I_{ref} = 10 \mu\text{A}$	5.8	6.4	7.0	V_{dc}
Reference Voltage Line Regulation	$9V \leq V_{CC} \leq 16V$, $I_{ref} = 10 \mu\text{A}$		± 5	± 50	mV_{dc}
Iset Voltage	$I_{set} = 20 \mu\text{A}$	1.20	1.40	1.60	V_{dc}
Input Offset Voltage	At Output Switch Point. $V_O = 2V$ $9V \leq V_{CM} \leq 16V$		± 1.0	± 5.0	mV_{dc}
Input Offset Current	$I_{IN(+)} - I_{IN(-)}$, $9V \leq V_{CM} \leq 16V$		± 0.10	± 1.00	μA_{dc}
Input Bias Current	$I_{IN(+)}$ or $I_{IN(-)}$, $9V \leq V_{CM} \leq 16V$	18.00	20.00	22.00	μA_{dc}
Input Common Mode Voltage Range		4.00		26.0	V_{dc}
Maximum Positive Input Transient	Either Input. $T \leq 100$ ms	60	70		V
Maximum Negative Input Transient	Either Input. $T \leq 100$ ms	-50	-60		V
Output Saturation Voltage	$I_O = 2$ mA, $9V \leq V_{CC} \leq 16V$		0.80	1.00	V_{dc}
	$I_O = 10$ mA, $9V \leq V_{CC} \leq 16V$		1.00	1.20	V_{dc}
Output Short Circuit Current	$V_O = 0V_{dc}$, Comparator "ON"	20	45	120.0	mA_{dc}
Output Leakage Current	$V_O = 0V_{dc}$, Comparator "Off"		0.01	1.00	μA_{dc}
Test Threshold Voltage	At Switch Point on Any Output $V_O = 2V$ (Note 2)	0.80	1.25	2.00	V_{dc}
Test Threshold Current			0.2		μA_{dc}

Note 1: Thermal resistance from junction to ambient is typically 53°C/W (board mounted).

Note 2: The test pin is an active high input, i.e. all five will be forced high when this pin is driven high.

Note 3: $C_{ESD} = 100$ pF, $R_{ESD} = 1.5k$

Connection Diagram

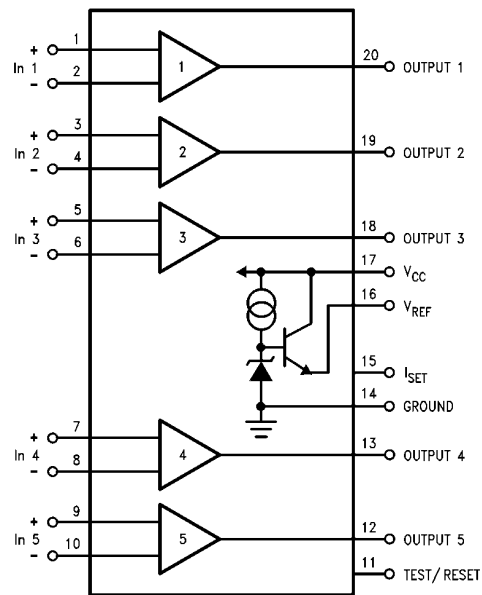

TL/H/8707-20

Order Number LM1946N or LM1946M
See NS Package Number M20B or N20A

Typical Test Circuit

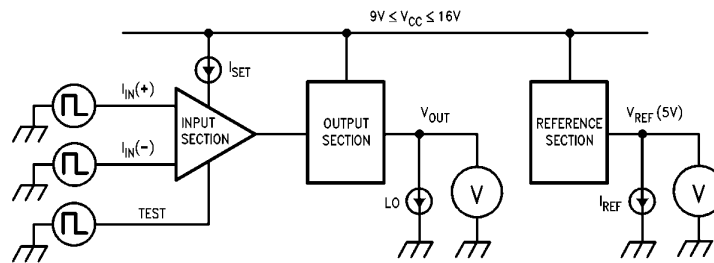

TL/H/8707-23

Simplified Comparator Schematic

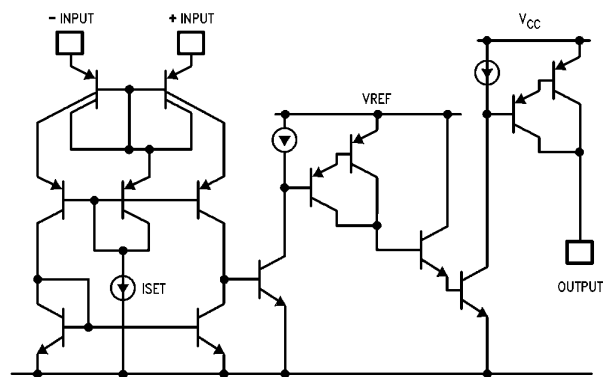

TL/H/8707-24

Typical Performance Characteristics

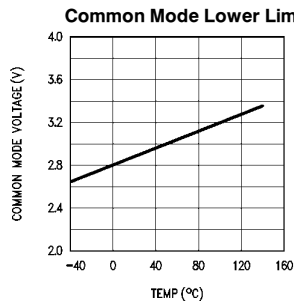
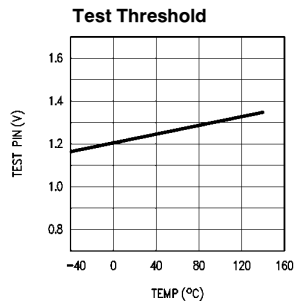
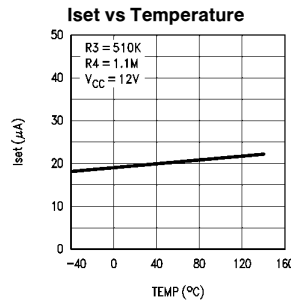
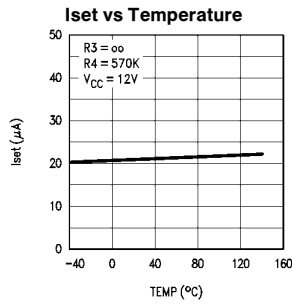
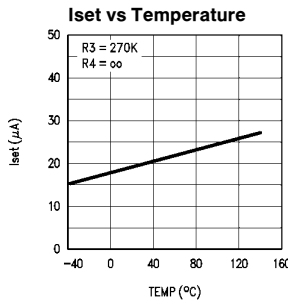
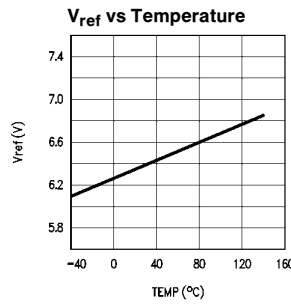
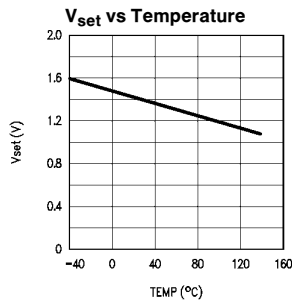
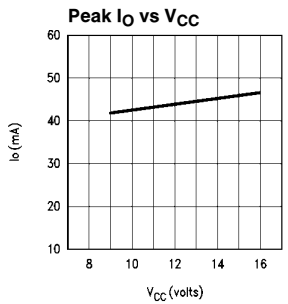
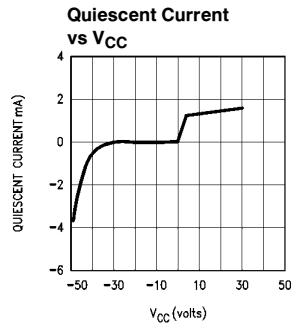
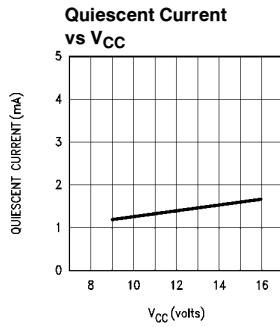
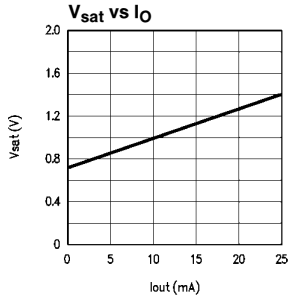

TL/H/6707-4

Application Hints

THEORY OF OPERATION: UNDER-CURRENT LIMIT DETECTOR

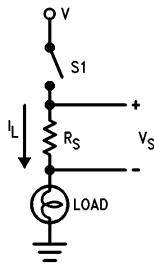

TL/H/8707-6

Lamp Fault Detector

FIGURE 3. Equivalent Automotive Lamp Circuit

The diagram of *Figure 3* represents the typical lamp circuit found in most automobiles. Switch S1 represents a dashboard switch, discrete power device, relay and/or flasher circuit used for turn signals. Sense resistor R_S can be an actual circuit component (such as a 0.1Ω 1W carbon resistor) or it can represent the resistance of some or all of the wiring harness. The load, represented here as a single bulb, can just as easily be two or more bulbs in parallel, such as front and rear parking lights, or left and right highbeams, etc.

One of the easiest methods to electronically monitor proper bulb operation is to sense the voltage developed across R_S by the bulb current I_L . If a fault occurs due to an open bulb filament, the load current, and sense voltage V_S , drop to zero (or to half their former values in the case of two bulbs wired in parallel). A comparator circuit can then monitor this sense voltage, and alert the system or system user (e.g. power an LED) if this sense voltage drops below a predetermined level (defined as the threshold voltage).

Typical sense voltages range from tens to hundreds of millivolts. Not only does this sense voltage vary nonlinearly with the battery voltage, it may vary significantly with ambient temperature depending on the temperature coefficient (TC) of the sense resistor or wiring harness. Since these nonlinear characteristics can vary from system to system, and sometimes even within a single system, provisions must be made to accommodate them. There are two general methodologies to accomplish this.

The first method uses only one bulb per monitoring circuit. A sense resistor is selected to give 50–100 mV of sense voltage in an operational circuit, and a comparator threshold detecting voltage of approximately 10 mV is set. Even if component tolerances, battery line variations, and temperature coefficients cause the sense voltage to vary 3:1 or more, circuit operation will not be affected.

The second method must be used if two or more bulbs are wired in parallel and it is necessary to detect if any single lamp fails. This is often desirable as it reduces the number of comparators and displays and system cost by at least a factor of two. In this case, the sense voltage will drop by only half (or less) of its original value. For example, a nominal 100 mV drop across the sense resistor will drop to 50 mV if one of two bulbs fail. Therefore, a threshold detection voltage between 50 and 100 mV is required (since a

10 mV threshold would alert the system only if **both** bulbs failed). Yet a fixed threshold of 75 mV may not work if the nominal 100 mV sense voltage can vary 3:1 due to the factors mentioned earlier. What is required is a comparator with a threshold-detecting voltage that tracks the nominal sense voltage as battery line and ambient temperature change. Thus, while the sense voltage may nominally be anywhere from 50 to 150 mV, the threshold voltage will always be roughly 75% of it, or 37 mV to 112 mV, and will detect the failure of either of two bulbs.

The LM1946 integrated circuit contains five comparators especially designed for lamp monitoring requirements. Since all lamps in a system share the same battery voltage and ambient temperature, accommodations for these variations need to be made only once at the IC, and each threshold of the five comparators then tracks these variations.

SETTING THE COMPARATOR THRESHOLD VOLTAGE

The threshold voltage at which the comparator output changes state is user-set in order to accommodate the many possible system designs. The input bias currents are purposely high to accomplish this, and are each equal to the user-set current into the Iset pin (more on this later). Typically around 20 μA, the effect of this across the sense resistor R_S compared to a typical load measured in amps is negligible and can be ignored. However, when resistors R1 and R2 (*Figure 4*) are added to the circuit, a shift in the threshold voltage is effected. This occurs since each input has been affected by different IR drops. The LM1946 behaves like any other comparator in that the output switches when the input voltage at the IC pins is zero millivolts (ignoring offset voltage for the moment). If the output therefore has just switched states due to just the right threshold voltage across the sense resistor, then the sum of voltages around the resistor loop should equal zero:

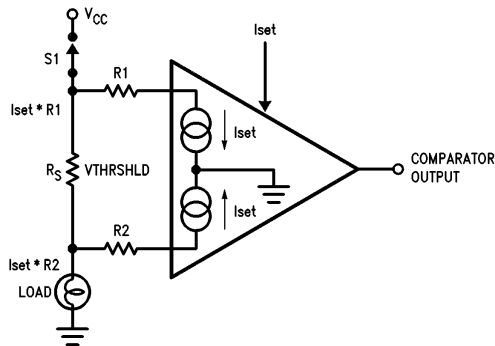

TL/H/8707-9

$$V_{thrsld} = I_{set} (R1 - R2)$$

FIGURE 4. Input Bias Current

$$V_{thrsld} + I_{set} \cdot R2 - V_{offset} - I_{set} \cdot R1 = 0$$

Assuming $V_{offset} \ll V_{thrsld}$:

$$V_{thrsld} = I_{set} \cdot R1 - I_{set} \cdot R2$$

$$V_{thrsld} = I_{set} (R1 - R2)$$

Application Hints (Continued)

Typical values are:

$$R1 = 6.2k \pm 5\%$$

$$R2 = 1.2k \pm 5\%$$

$$I_{set} = 20 \mu A @ 25^\circ C$$

$$V_{thrsld} = 20 \mu A (6.2k - 1.2k) = 100 mV$$

For values of sense voltages greater than 100 mV, the comparator output is off (low). Sense voltages less than 100 mV turn the output on (high).

It's also important that the output of the comparator be in the "off" state when the inputs are taken to ground, i.e. S1 is opened and the lamp is turned "off". The input section of LM1946 has been designed to turn "off" when the inputs are grounded and therefore not deliver an erroneous bulb out indication. The comparator is only activated when the inputs are above ground by at least 3V.

R1 and R2 are necessary for another reason. These resistors protect the input terminals of the IC from the many transients in an automobile found on the battery line, some of which can exceed a thousand volts for a few microseconds. A minimum value of approximately 1 k Ω is therefore recommended.

COMPENSATING FOR BATTERY VOLTAGE

The current through a typical automotive lamp, whether a headlight or dashboard illumination lamp, will vary as battery voltage changes. The change, however, is nonlinear. Doubling the battery voltage does not double the lamp current.

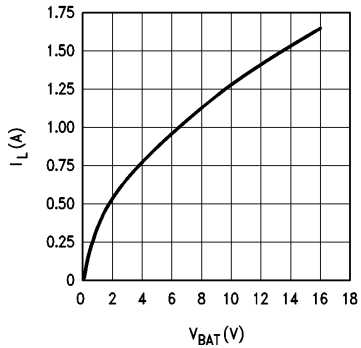
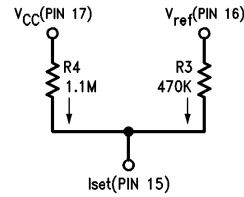

FIGURE 5

TL/H/8707-21

This occurs since a higher voltage will heat the filament more, increasing its resistance and allowing less current to flow than expected. Figure 5 shows this effect. A best fit straight line over the normal battery range of 9V to 16V for this particular example can be given by:

$$I_L (\text{Amps}) = 0.62 + 0.069 \cdot V_{\text{battery}}$$



TL/H/8707-10

$$I_{set} = \frac{V_{CC} - 1.4}{R4} + \frac{V_{ref} - 1.4}{R3}$$

$$I_{set} = \frac{V_{CC}}{R4} + \frac{V_{ref}}{R3} - 1.4 \left(\frac{1}{R3} + \frac{1}{R4} \right)$$

FIGURE 6

Thus, in actual use, the LM1946 threshold voltage should track the variations in bulb current with respect to battery voltage. To accomplish this, Iset should have a component that varies with the battery. As shown in the LM1946 circuit schematic of Figure 18, the Iset pin is two diode drops above ground, or approximately 1.4V. A resistor from this pin to the 6.4V reference sets the fixed component of Iset; a resistor to the battery line sets the variable component. Thus, the best fit straight line in Figure 5 can be realized exactly with only two resistors. The result is shown in Figure 6, giving a nominal Iset of 20 μA that tracks the bulb current as supply varies from 9V to 16V. The graph of Figure 7 shows the final result comparing a typical sense voltage across R_s with the comparator threshold voltage as the supply varies.

COMPENSATING FOR AMBIENT TEMPERATURE VARIATION

If the sense resistors used in a system are perfect components with no temperature coefficient, then the compensation to be subsequently detailed here is unnecessary. However, resistors of the very small values usually required in a lamp monitoring system are sometimes difficult or expensive to acquire. A convenient alternative is the wiring harness, a length of wire, or even a trace on a printed circuit board. All of these are of copper material and therefore can vary by as much as 3900 ppm/ $^\circ C$. The LM1946 has been designed to accommodate a wide range of temperature compensation techniques. If the Iset current is designed to increase or decrease with temperature, nearly any temperature coefficient can be produced in the threshold voltage of the five input pairs.

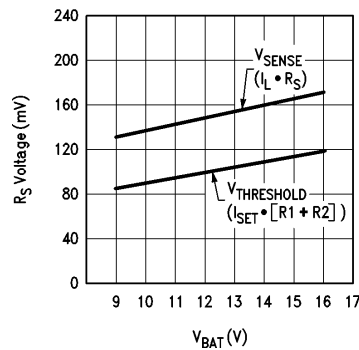

FIGURE 7

TL/H/8707-22

Application Hints (Continued)

One solution is to use a low cost thermistor in conjunction with some low-TC resistors (see *Figure 8*).

There are three fixed resistors and one thermistor. This is an NTC thermistor, since it has a **negative** temperature coefficient. This is what is required in order to have I_{set} **increase** as the temperature rises. The data sheet with the thermistor described a number of ways to establish different final TC's. The thermistor itself has a very large TC which is somewhat difficult to describe mathematically. But, if it is used with some other fixed resistors, such as R_{min} and R_{max} , definite end point limits can be established and an

approximate straight line TC generated. See *Figure 9* for a graphic representation of the ideal calculated values of I_{set} and the actual measured values generated. Notice that there is very close agreement between the two graphs. The circuit actually creates an S-shaped curve around the ideal.

The low-cost thermistor is available from Keystone and is listed as follows: RL2008-52.3K-155-D1.

OVER-CURRENT LIMIT DETECTOR

Other applications include an over-current detector, as shown in *Figure 10*. The load represented here can be either a single component or an entire system. Resistors R3

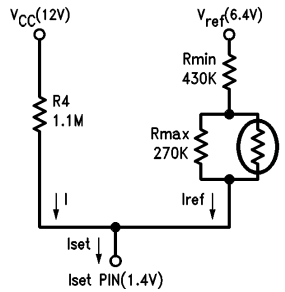

Thermistor
Keystone:
RL2008-52.3K-155-D1
100k @ 25°C

TL/H/8707-11

FIGURE 8. Thermistor/Resistor Network

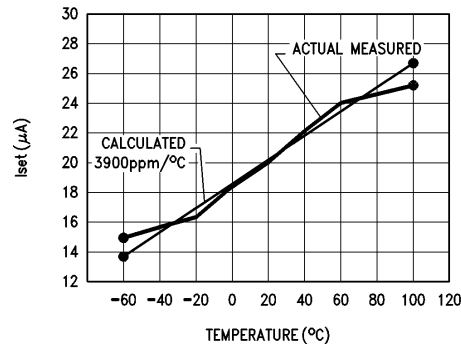

TL/H/8707-12

FIGURE 9. I_{set} vs Temperature with *Figure 8* Circuit

Application Hints (Continued)

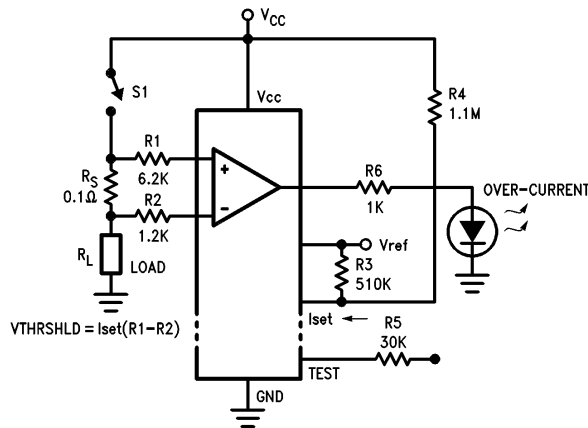

FIGURE 10. Using the LM1946 as an Over-Current Limit Detector

TL/H/8707-7

and R4 again allow the system designer to tailor the threshold limit to the V/I characteristics of each particular system. The input threshold voltage is determined by, and directly proportional to, Iset into pin 20. R3, from the on-chip reference voltage, provides a current and threshold that is independent of the supply voltage, V_{CC}. R4 provides a current directly proportional to supply. These resistors allow thresholds to be either independent of, or directly proportional to supply voltage, or anything in between. For example, the values in Figure 10 are tailored to match the V/I characteristics of the bulb filament used in earlier examples. However, if the load had purely resistive characteristics, Iset and the threshold would be set with R4 only, eliminating R3. Likewise, if the load current was independent of supply, such as in many systems powered by a voltage regulator, Iset would be better set by R3 only, eliminating R4. Further details on this and how to handle variations with ambient temperature with resistor and thermistor combinations are discussed in detail in previous sections. Compensation for temperature variations, however, is rarely necessary since short circuit or over-current values are usually much greater than the nominal value. For example, if the load in Figure 10 represented a DC motor, the circuit could be used to detect the motor stall condition. Stall current through the sense resistor, R_S, would typically be five times the nominal running current. By setting the threshold at three times the nominal current value, enough margin exists that minor variations due to temperature can be ignored. The variation in stall current due to battery or supply voltage can be significant, however. Being approximately proportional, Iset would best be set in this case by R4 only.

WINDOW DETECTOR

The availability of more than one comparator per IC allows many other applications. One is the current sense window detector. Many times it is useful to know that a certain current is within both an upper and lower limit. Using two of the LM1946 comparators and the circuit of Figure 11 will accomplish this. In this particular case, high and low limits

are approximately 3A and 1A respectively. The outputs can be kept separate or wired-or, as shown, to a single output load as a simple out-of-bounds detector.

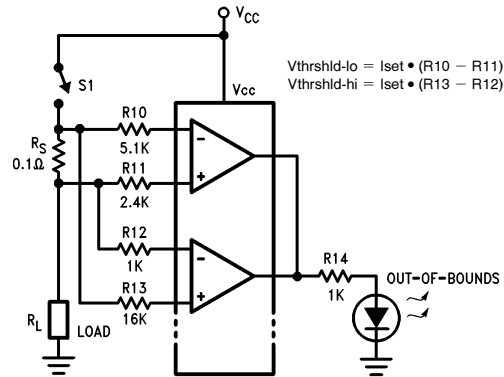

FIGURE 11. Current Limit Window Detector

TL/H/8707-8

COMPARATOR INPUT STAGE

The LM1946 IC consists of five specially designed comparator input circuits to monitor the IR drop across the wiring harness or the sense resistor between the battery and the light bulb. These comparators have been designed to accommodate a wide range of input signals without damage to the IC or the load circuitry. The inputs can easily withstand a common mode voltage above the positive supply since the inputs are the emitters of two matched PNP devices (see Figure 12). This is vital in a system which must operate in the conditions present under the hood of an automobile. The inputs can also survive when taken well below ground. If a negative voltage is present at the inputs of the comparator, the two emitter-base PNP junctions become reverse biased and block any current flow in or out of the device. To disable an unused comparator it is recommended that the inputs be connected to ground.

Application Hints (Continued)

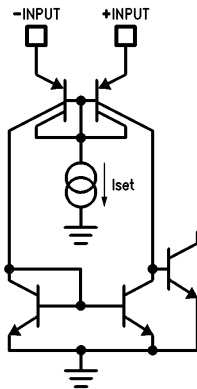

TL/H/8707-13

FIGURE 12. Comparator Input Stage

THE OUTPUT SECTION

The output section of the LM1946 is different from most automotive comparators as it employs high beta proprietary PNP transistors which are very rugged and capable of higher output currents. Each of the five comparator outputs is capable of at least 20 mA of drive and are internally current limited and protected against supply overvoltage. The LM1946 is therefore capable of driving LED's directly and larger bulbs via an external grounded base NPN (see *Figures 13 and 14*). The outputs can also be wired-or together without harm.

For use in systems with a microprocessor flag instead of a dashboard indicator, the LM1946 can be powered by a standard 5V logic supply. This prevents the LM1946 output from swinging above the microprocessor supply which might cause latch problems. Since the input common mode range is independent of supply, the inputs can still operate at any level up to 26V. Since the outputs can source current only, pull-down resistors as in *Figure 15* are required, their value depending on the input drive requirements of the particular microprocessor used. When operating with a V_{CC} supply less than 7V, it is important to connect the V_{REF} pin to V_{CC} . This forces V_{REF} to a fixed voltage which is used for bias of internal circuitry.

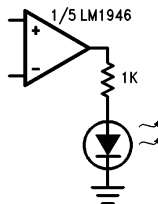

TL/H/8707-19

FIGURE 13

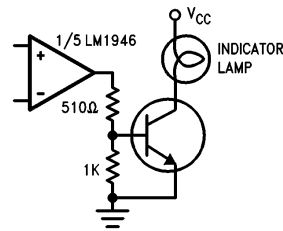

TL/H/8707-14

FIGURE 14

TEST PIN

The test pin is a high impedance logic input. Forcing this pin high ($\geq 2V$) forces all five comparator outputs on. This is used to test the indicator LED display (or other output load). The usual application circuit connects this pin to the ignition crank line. During engine crank, therefore, the LM1946 output display will light, similar to the usual dashboard indicators. The test pin was designed to operate with the usual transient voltages found on the crank line as long as a limiting resistor (e.g. 30k) separates them (*Figure 1*).

$$\text{Minimum pulse width (ms)} \approx 0.01 + 1.5 \cdot C1 (\mu F)$$

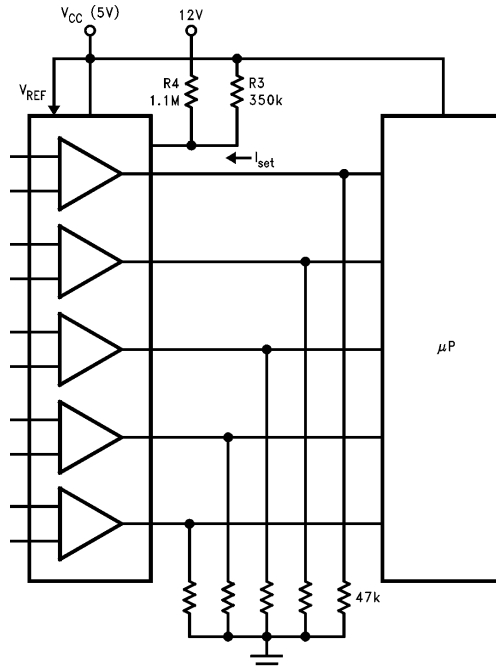

TL/H/8707-15

FIGURE 15

Application Hints (Continued)

MORE NOISE FILTERING

The current flowing through the sense resistor and certain loads can sometimes be very noisy, particularly when the load is a DC motor, or switching supply. Large amounts of noise on the supply line can also cause problems when threshold voltages are set to very small values. In these cases, while the average current level may remain well below the threshold trip point, noise peaks may exceed it. A LED display could then flicker or appear dimly lit, or excessive software routines and processor time may be required for a μP to disregard such noise. Often such noise must be filtered directly at the inputs, using the input resistors R1 and R2 and a capacitor. Care must be taken, however, that such a filter will not cause an erroneous output state upon power-up or whenever switch S1 is closed. The most effective general methodology to achieve this is to split the resistor in the positive input lead into two resistor values and connect a capacitor from here to the negative input. For example, the 1.2k resistor R2 of *Figure 10* could be replaced with 3.9k and 1.2k resistors as shown in *Figure 16a* (R1 increasing from 6.2k to 10k to compensate). The value of capacitor C2 depends upon the degree of filtering required, the amount of noise present, and the response times desired. The choice of values for the new resistors is almost arbitrary. Generally the larger value is attached to the sense resistor for better decoupling. The smaller value must be large enough so that the DC voltage across it upon power-up exceeds the maximum offset voltage expected of the comparator (i.e. $I_{\text{set}} \cdot R2b > 5.0\text{mV}$). It is this requirement that guarantees that the output will not be in an erroneous high state upon power-up or whenever S1 is closed. (Should this feature be unnecessary to a particular application circuit, the methodology described can be replaced with a simple capacitor across the comparator input pins).

For extremely severe cases, additional filter stages can be cascaded at the inputs (see *Figure 17*). Since the input bias currents of the comparator are equal at the input threshold level, the voltage drops across the 1k resistors cancel and do not affect the DC operation of the circuit (ignoring resistor match tolerance and loss). If an application circuit is noisy enough to require such an elaborate filter, then ferrite beads, shown here as L1 and L2, will also probably help.

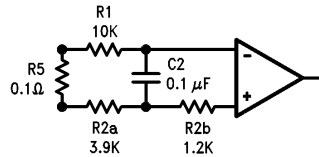

TL/H/8707-16

a. Open-Circuit Detector

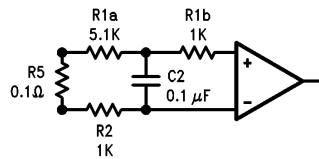

TL/H/8707-17

b. Over-Current Limit Detector

FIGURE 16. Input Noise Filters for Various Application Circuits

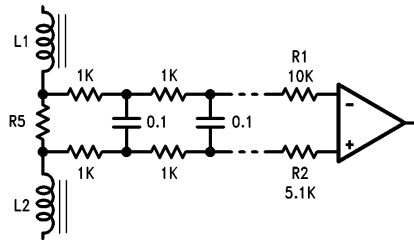

TL/H/8707-18

FIGURE 17. Additional Noise Filters

Circuit Schematic

TL/H/8707-3

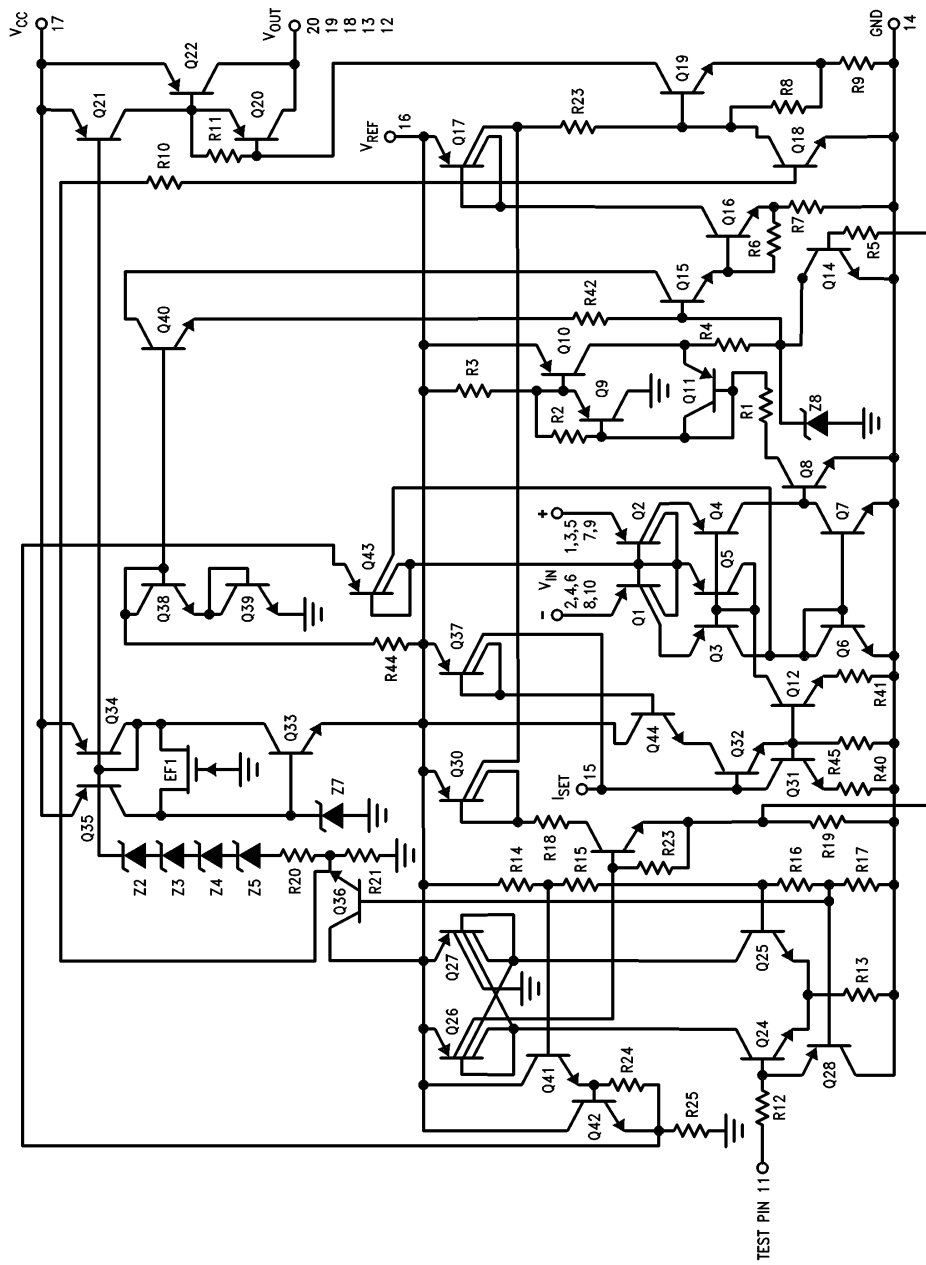
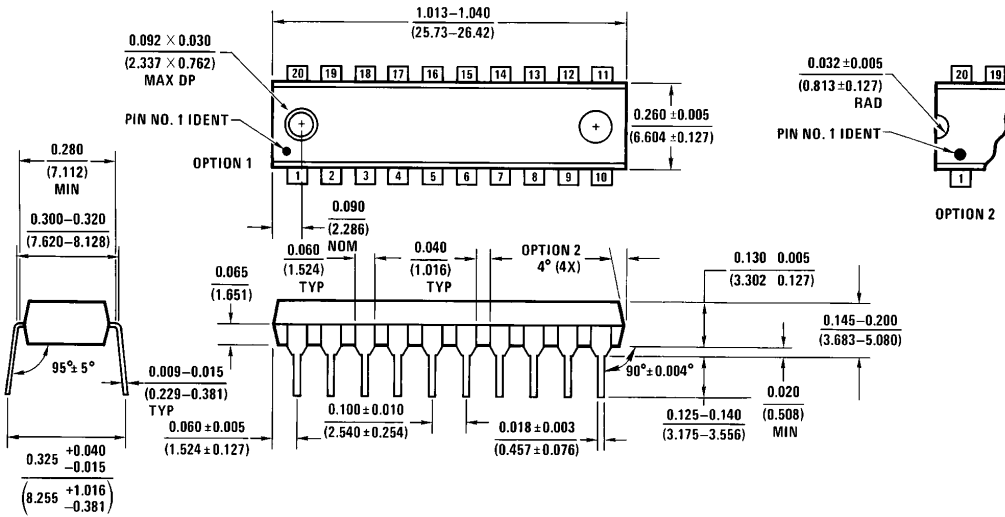

FIGURE 18

Physical Dimensions inches (millimeters)



**20-Lead Molded Dip (N)
Order Number LM1946N
NS Package Number N20A**

N20A (REV G)

LIFE SUPPORT POLICY

NATIONAL'S PRODUCTS ARE NOT AUTHORIZED FOR USE AS CRITICAL COMPONENTS IN LIFE SUPPORT DEVICES OR SYSTEMS WITHOUT THE EXPRESS WRITTEN APPROVAL OF THE PRESIDENT OF NATIONAL SEMICONDUCTOR CORPORATION. As used herein:

1. Life support devices or systems are devices or systems which, (a) are intended for surgical implant into the body, or (b) support or sustain life, and whose failure to perform, when properly used in accordance with instructions for use provided in the labeling, can be reasonably expected to result in a significant injury to the user.
2. A critical component is any component of a life support device or system whose failure to perform can be reasonably expected to cause the failure of the life support device or system, or to affect its safety or effectiveness.



National Semiconductor Corporation
1111 West Bardin Road
Arlington, TX 76017
Tel: 1(800) 272-9959
Fax: 1(800) 737-7018

National Semiconductor Europe
Fax: (+49) 0-180-530 85 86
Email: cnjwge@tevm2.nsc.com
Deutsch Tel: (+49) 0-180-530 85 85
English Tel: (+49) 0-180-532 78 32
Français Tel: (+49) 0-180-532 93 58
Italiano Tel: (+49) 0-180-534 16 80

National Semiconductor Hong Kong Ltd.
19th Floor, Straight Block,
Ocean Centre, 5 Canton Rd.
Tsimshatsui, Kowloon
Hong Kong
Tel: (852) 2737-1600
Fax: (852) 2736-9960

National Semiconductor Japan Ltd.
Tel: 81-043-299-2309
Fax: 81-043-299-2408

National does not assume any responsibility for use of any circuitry described, no circuit patent licenses are implied and National reserves the right at any time without notice to change said circuitry and specifications.