

SPECIFICATION FOR APPROVAL

CUSTOMER	_____
CUST. PART NO.	_____
CUST. DOC. REV.	_____
DESCRIPTION	CHIP INDUCTORS (RoHS+H.F.)
SAMPLE LOT NO.	_____
PART NO.	0805F-XXXX-LRH
DOC. REV.	_____
DATE	_____

Once you approve this part, please sign and return this page to the following marked location.

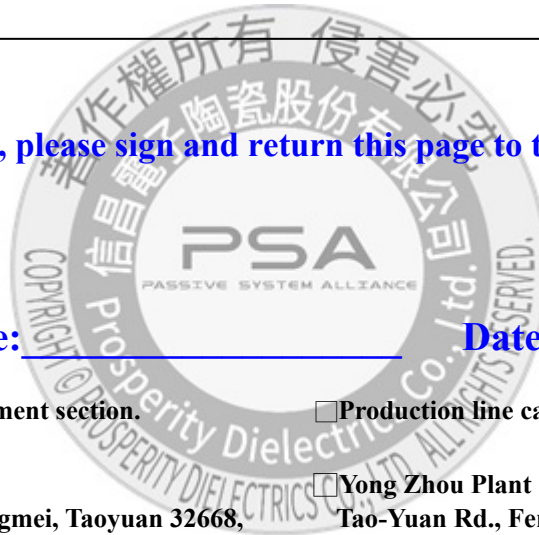

Customer Signature: _____ **Date:** _____

This part currently development section. Production line can produce this series of products.

■ Sales Office-Headquarter

No. 566-1, Kao-Shi Rd., Yangmei, Taoyuan 32668,
Taiwan
TEL: +886-3-475-3355
FAX: +886-3-485-4959

Yong Zhou Plant

Tao-Yuan Rd., Fenghuang Park, Lengshuitan
District, Yongzhou, Hunan 425000, P.R.C.
TEL: +86-746-8610-180
FAX: +86-746-8610-181

Sales Office-Dong Guan, China

No.638, Mei Jing West Road Xiniupo Administrative
Zone Dalang Town, Dong Guan City, Guangdong
Province, China.
TEL: +86-769-8555-0979
FAX: +86-769-8555-0972

TESTED BY	CHECKED BY	APPROVED BY

TABLE OF CONTENTS

INDEX	Page
■ Engineering Change Notice – Record	2
■ Scope	3
■ Part Number Identification	3
■ Mechanical Dimension	3
■ Rating Temperature	3
■ Marking	3
■ Structure	4
■ Material List	4
■ Test Instrument	4
■ Electrical Specification	5
■ Reliability Performance	6
■ Reflow Chart	7
■ Packing	8 ~ 9
■ Test Report	

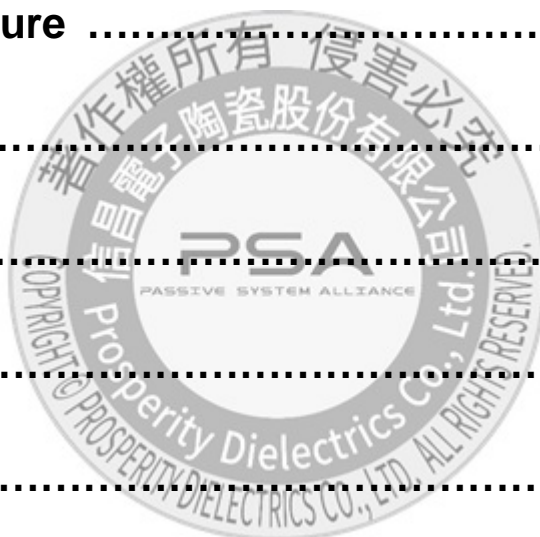

SPECIFICATION FOR APPROVAL

CUSTOMER	CUSTOMER P/N	REV. -	SPL. LOT NO.	
PART NAME CHIP INDUCTORS (RoHS+H.F.)	PART NO. 0805F-XXXX-LRH	REV.	DATE OF ISSUE	Q'TY 0 PCS

ENGINEERING CHANGE NOTICE – RECORD

REVISION NO.	REVISION DESCRIPTION	AUTHOR	DATE	REMARK
ORIG				



SPECIFICATION FOR APPROVAL

- ※This is a RoHS and REACH compliant product whose related documents are available on request.
- ※Graphic is only for dimensionally application.

1. SCOPE: THIS SPECIFICATION APPLIES TO WIRE WOUND CHIP INDUCTORS.

2. PART NUMBER IDENTIFICATION

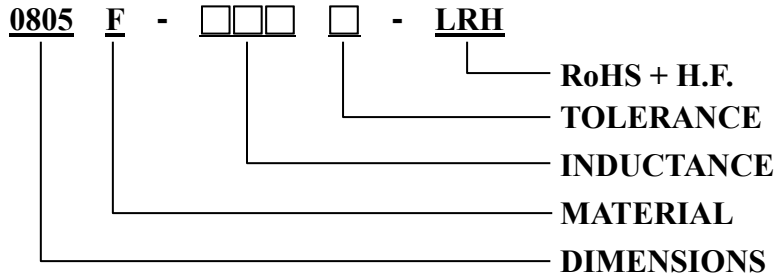

3. MECHANICAL DIMENSION

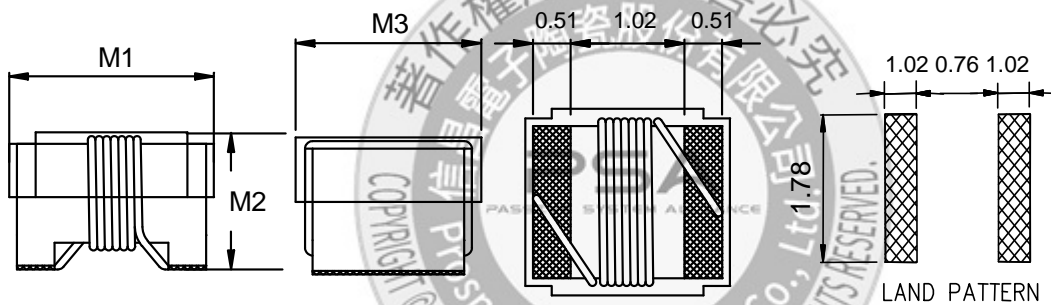

M1	M2	M3
2.29(MAX)	1.60(MAX)	1.91(MAX)

4. RATING TEMPERATURE

OPERATING TEMPERATURE: -25°C ~ +125°C

Moisture Sensitivity Level: Level 1

5. MARKING

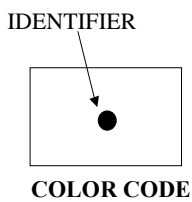

Example: 0805F-2R7□-LRH

MARKING: GRAY

MARK COLOR CODE IN COMPOSITE SPECIFICATION 9

SPECIFICATION FOR APPROVAL

6. STRUCTURE

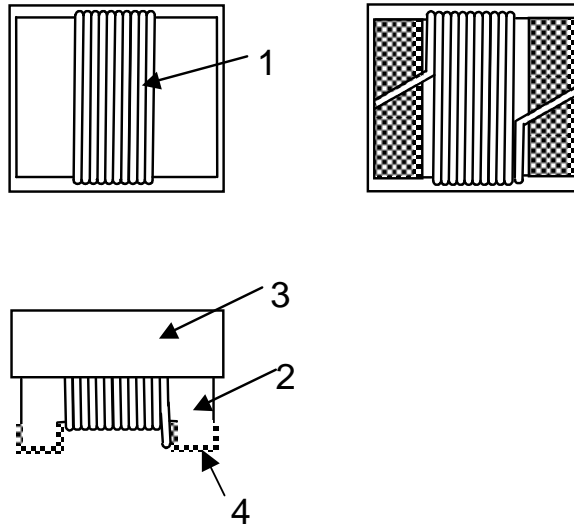

7. MATERIAL LIST

ITEM	MATERIAL CATEGORY	MATERIAL TYPE	UL NO.
1	WIRE	POLYSOL (P180)	E143312
2	CORE	FERRITE CORE	
3	UV	UV	
4.	TERMINAL PLATING	AgPd+Sn+Ni	

8. TEST INSTRUMENT:

8-1 L、Q TEST BY HP4291B

8-2 SRF TEST BY HP 8753E

8-3 DCR TEST BY ZENTECH 502B

SPECIFICATION FOR APPROVAL

9. ELECTRICAL SPECIFICATION

Part number	Inductance (μ H)	Test Frequency (MHz)	Inductance Tolerance	Q MIN.	SRF (MHz) MIN.	DC Resistance (Ω) MAX.	Irms (A)	COLOR CODE
0805F-78N□-LRH	0.078	7.9	K,J	19	1440	0.042	2.0	BLACK
0805F-R11□-LRH	0.110	7.9	K,J	19	1400	0.05	2.0	BROWN
0805F-R18□-LRH	0.180	7.9	K,J	15	1000	0.15	0.500	GARY
0805F-R22□-LRH	0.220	7.9	K,J	15	1000	0.15	0.500	VIOLET
0805F-R33□-LRH	0.330	7.9	K,J	15	862	0.25	0.300	WHITE
0805F-R39□-LRH	0.390	7.9	K,J	15	800	0.30	0.500	BLACK
0805F-R47□-LRH	0.470	7.9	K,J	19	500	0.31	0.720	RED
0805F-R56□-LRH	0.560	7.9	K,J	12	600	1.20	0.300	RED
0805F-R68□-LRH	0.680	7.9	K,J	20	400	0.46	0.590	ORANGE
0805F-R82□-LRH	0.820	7.9	K,J	12	600	1.00	0.300	YELLOW
0805F-1R0□-LRH	1.0	7.9	K,J	20	340	0.69	0.500	YELLOW
0805F-1R2□-LRH	1.2	7.9	K,J	20	400	0.75	0.800	BLACK
0805F-1R5□-LRH	1.5	7.9	K,J	20	275	0.83	0.490	GREEN
0805F-1R8□-LRH	1.8	7.9	K,J	20	246	1.15	0.410	BLUE
0805F-2R2□-LRH	2.2	7.9	K,J	20	106	1.28	0.365	VIOLET
0805F-2R7□-LRH	2.7	7.9	K,J	20	105	1.48	0.350	GRAY
0805F-3R3□-LRH	3.3	7.9	K,J	20	83	1.57	0.330	WHITE
0805F-3R9□-LRH	3.9	7.9	K,J	20	52	1.70	0.300	BLACK
0805F-4R7□-LRH	4.7	7.9	K,J	20	50	1.87	0.280	BROWN
0805F-5R6□-LRH	5.6	7.9	K,J	18	40	2.00	0.270	BLUE
0805F-6R8□-LRH	6.8	7.9	K,J	20	35	2.25	0.260	RED
0805F-8R2□-LRH	8.2	2.5	K,J	18	27	2.55	0.250	ORANGE
0805F-100□-LRH	10	2.5	K,J	18	21	3.45	0.200	YELLOW
0805F-120□-LRH	12	2.5	K,J	18	37	3.80	0.220	BROWN
0805F-150□-LRH	15	2.5	K,J	18	17	5.03	0.180	GREEN
0805F-180□-LRH	18	2.5	K,J	18	23	4.48	0.180	ORANGE
0805F-220□-LRH	22	2.5	K,J	18	13	6.18	0.150	BLUE
0805F-270□-LRH	27	2.5	K,J	15	11	11.04	0.120	VIOLET

NOTE:

□ Tolerance: K:±10%、J:±5%

SPECIFICATION FOR APPROVAL

10. RELIABILITY PERFORMANCE

Reliability Experiment For Electrical

Test Item	Accept criteria	Test Condition	Standard Source
Humidity Test	1.Change from an initial value L:within±5% 2.no visible damage.	+40°C± 2°C, humidity of 90% ±5% (total 96 hours).	MIL-STD-202G Method 103B Test Condition B
High Temperature Test	1.Change from an initial value L:within±5% 2.no visible damage.	1.Temperature: +125°C±2°C. 2.Test time: 48±2hrs.	IEC 68-2 Test Condition B
Low Temperature Test	1.Change from an initial value L:within±5% 2.no visible damage.	1.Temperature: -25°C±2°C. 2.Test time: 48±2hrs.	IEC 68-2 Test Condition A
Thermal Shock	1.Change from an initial value L:within±5% 2.no visible damage.	+125°C±5°C (30 minutes) ~ -55±5°C (30 minutes), temperature switch time: 5 minutes (total 50 cycles) Wind speeds 10m/sec.	Reference MIL-STD-202G Method 107G Test Condition A-2
Life Test	1.Change from an initial value L:within±5% 2.no visible damage.	+70°C±5°C (250Hours).	Reference MIL-STD-202G Method 108A Test Condition B

Reliability Experiment For Physical

Test Item	Accept criteria	Test Condition	Standard Source
Vibration Test	1.Change from an initial value L:within±5% 2.no visible damage.	10-55-10HZ, amplitude: 1.5mm, direction: X, Y, Z axes, each axis 2 hours (total 6 hours).	MIL-STD-202G Method 201A
Solder Heat Resistance Test	1.no visible damage.	IR/convection reflow: Peak Temp 255°C ~260°C for 3~5 Sec. in air, Through 2 Cycle. Temperature Ramp:+1~4°C/sec.; Above 217°C, must keep 90 s - 120 s.	Reference MIL-STD-202G Method 210F Test Condition K (Reflow)
Solder Ability Test	1. Lead must have 95% above coverage.	Soak in 245°C solder pot of 3~5 Sec.	Reference J-STD-002D

SPECIFICATION FOR APPROVAL

11. TYPICAL RoHS REFLOW PROFILE

Typical RoHS Reflow Profile

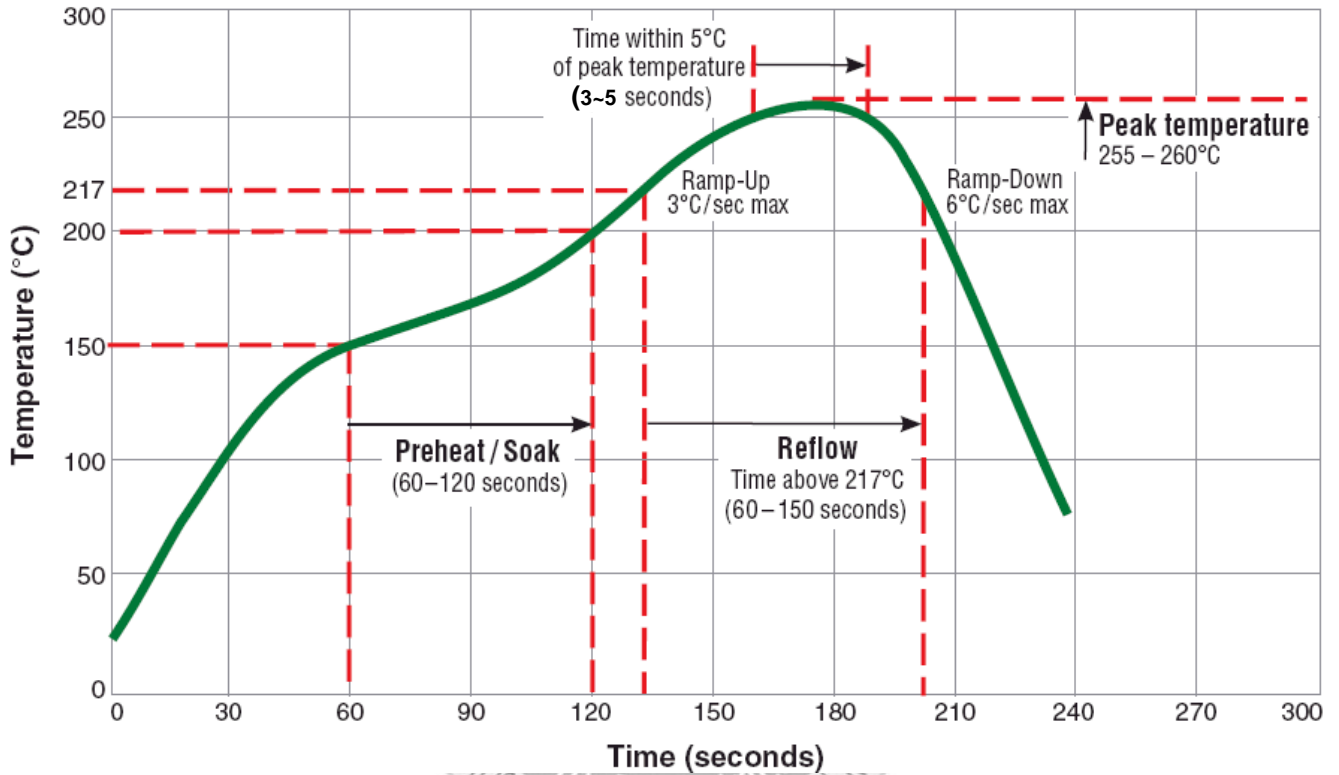

SPECIFICATION FOR APPROVAL

12. PACKING

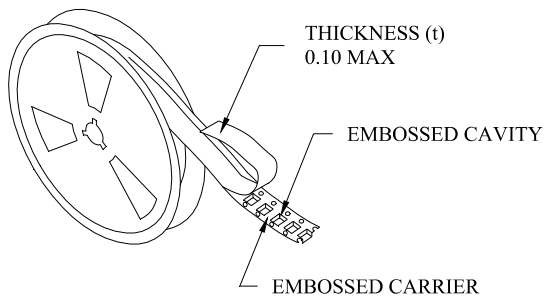

- THE FORCE FOR TEARING OFF COVER TAPE IS 10 TO 100 GRAMS IN THE ARROW DIRECTION.

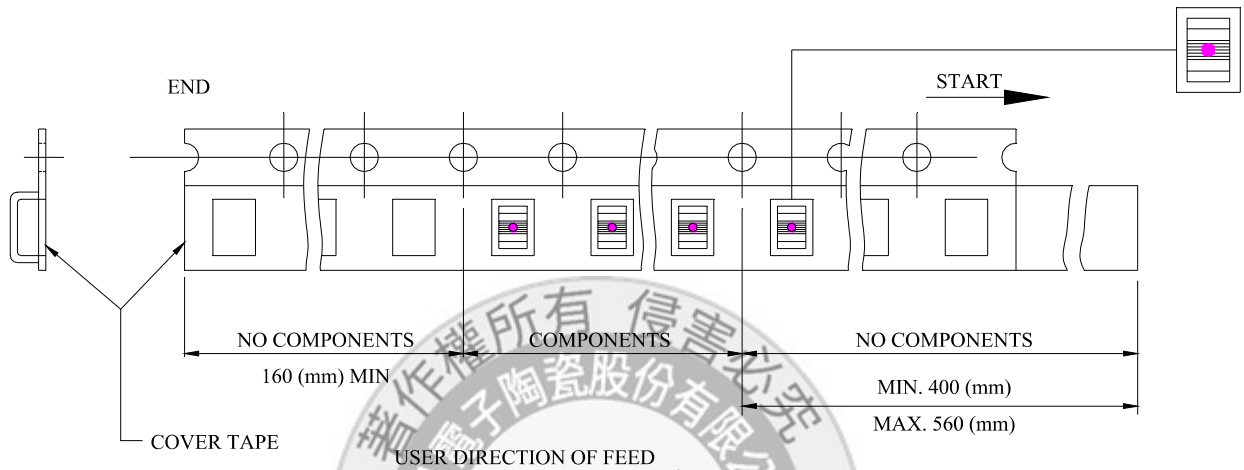
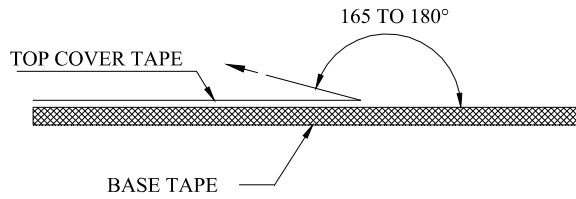

■ CARRIER TAPE REELS (mm)

MATERIAL: PLASTIC

■ DIMENSIONS OF CARRIER TAPE (mm)

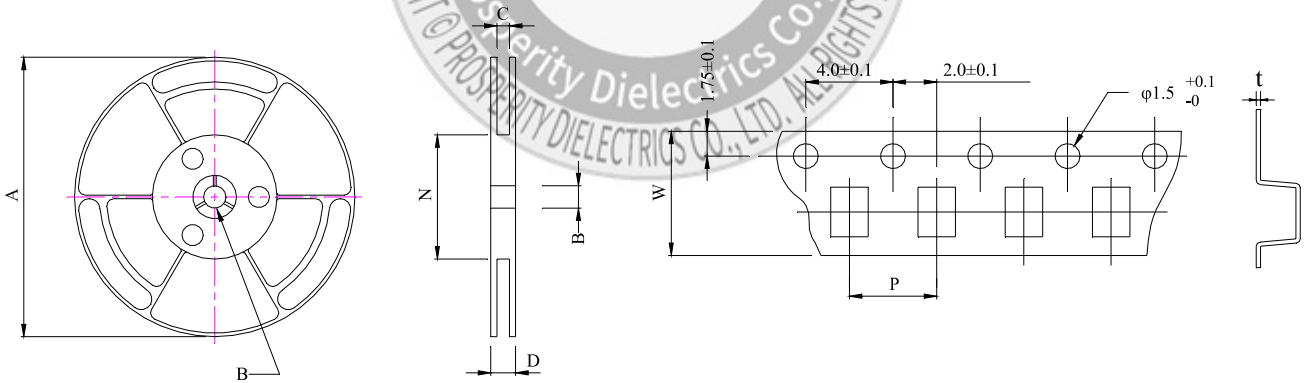

UNIT: mm

	A	B	C	D	N	P	W	t
DIM.	178	13.0	8.4	12.5	50	4.0	8.0	0.25
TOL.	±2.0	±0.8	+1.0-0	MAX	MIN	±0.1	±0.2	±0.05

SPECIFICATION FOR APPROVAL

UNIT : mm

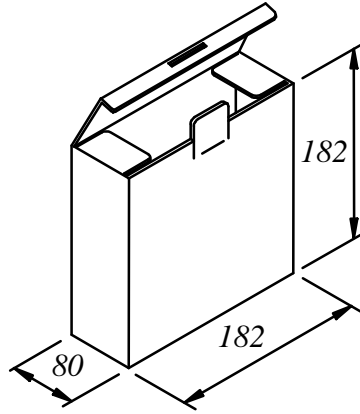

- CONSTRUCTION:
THE CASE CONTAINS 5-8mm WIDE CARRIER TAPES.
Q'TY : 3,000 / REEL

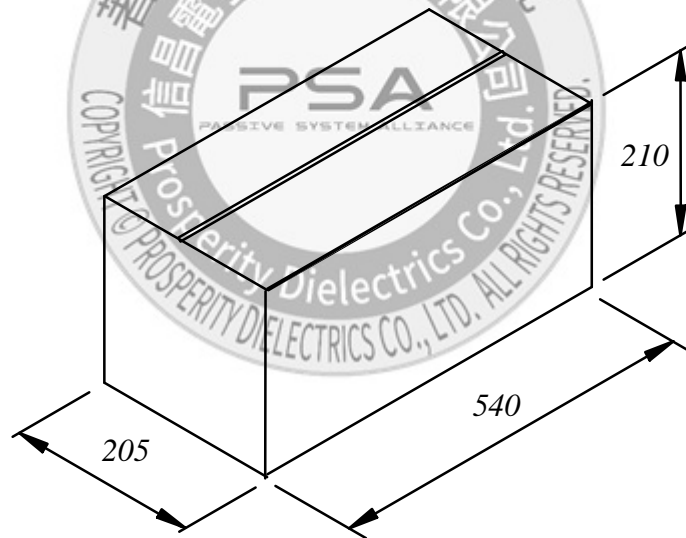

TOTAL Q'TY : 90,000PCS