

SPECIFICATION FOR APPROVAL

CUSTOMER	_____
CUST. PART NO.	_____
CUST. DOC. REV.	_____
DESCRIPTION	SMD CHIP BEAD(RoHS+H.F.)
SAMPLE LOT NO.	_____
PART NO.	FB201209AXXX-LRH
DOC. REV.	ORIG
DATE	_____

Once you approve this part, please sign and return this page to the following marked location.

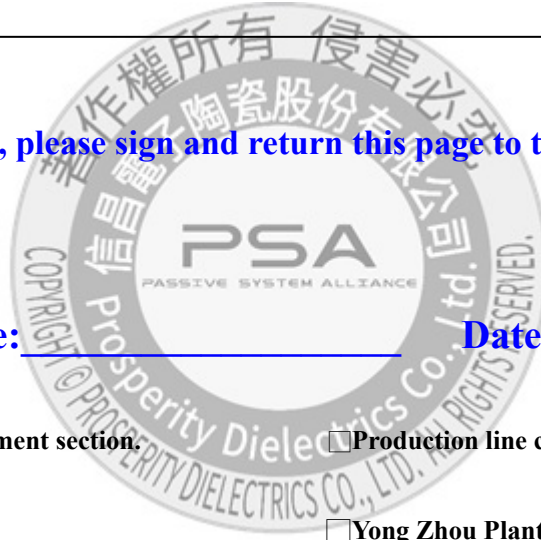

Customer Signature: _____ Date: _____

This part currently development section. Production line can produce this series of products.

Sales Office-Headquarter
No. 566-1, Kao-Shi Rd., Yangmei, Taoyuan 32668,
Taiwan
TEL: +886-3-475-3355
FAX: +886-3-485-4959

Yong Zhou Plant
Tao-Yuan Rd., Fenghuang Park, Lengshuitan
District, Yongzhou, Hunan 425000, P.R.C.
TEL: +86-746-8610-180
FAX: +86-746-8610-181

Sales Office-Dong Guan,China
No.638,Mei Jing West Road Xiniupo Administrative
Zone Dalang Town,Dong Guan City,GuangDong
Province,China.
TEL: +86-769-8555-0979
FAX: +86-769-8555-0972

TESTED BY	CHECKED BY	APPROVED BY

TABLE OF CONTENTS

INDEX	Page
■ Engineering Change Notice - Record	2
■ Part Number Identification	3
■ Mechanical Dimension	3
■ Electrical Specification	3
■ Electrical Curve	4
■ Reliability Performance	5
■ Reflow Chart	6
■ Packing	7
■ Test Report	

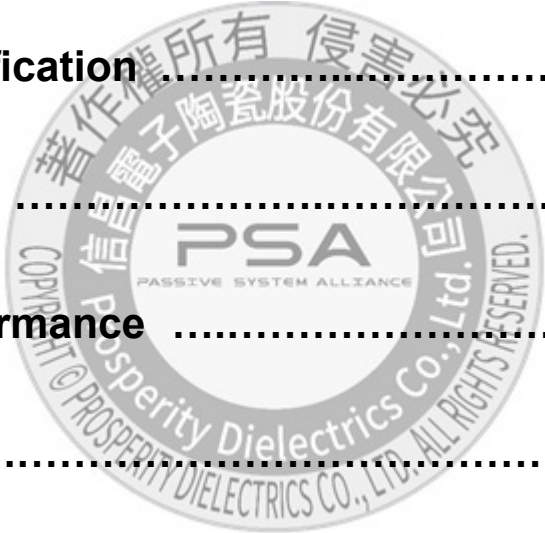

SPECIFICATION FOR APPROVAL

CUSTOMER	CUSTOMER P/N	REV. -	SPL. LOT NO.	
PART NAME SMD CHIP BEAD (RoHS+H.F.)	PART NO. FB201209AXXX-LRH	REV. ORIG	DATE OF ISSUE	Q'TY 0 PCS

ENGINEERING CHANGE NOTICE - RECORD

REVISION NO.	REVISION DESCRIPTION	AUTHOR	DATE	REMARK
ORIG		<i>Bruce Hsu</i>		



SPECIFICATION FOR APPROVAL

※This is a RoHS and REACH compliant product whose related documents are available on request.
 ※Graphic is only for dimensionally application.

1. PART NUMBER IDENTIFICATION

FB 201209 A □□□ - LRH

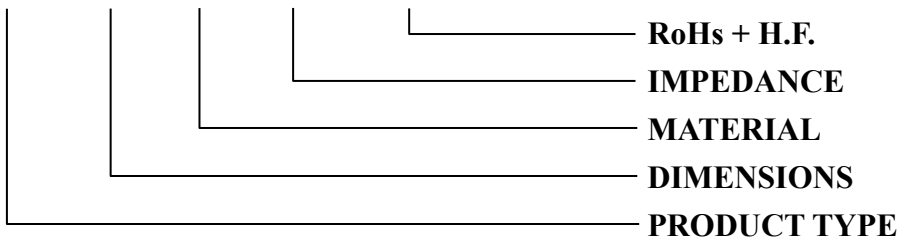

2. MECHANICAL DIMENSION

UNIT: mm

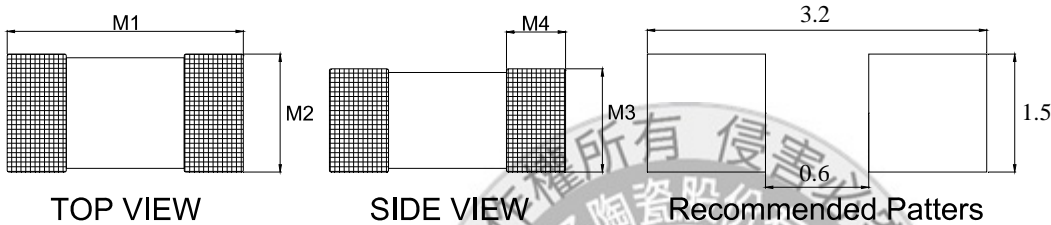

	DIM.	TOL.
M1	2.00	±0.20
M2	1.25	±0.20
M3	0.90	±0.20
M4	0.50	±0.30

3. ELECTRICAL SPECIFICATION

Part number	Impedance (Ω) ±25%	Test Frequency (MHz)	DC Resistance (Ω) MAX.	Rated Current (mA)
FB201209A300-LRH	30	100	0.05	800
FB201209A400-LRH	40	100	0.05	800
FB201209A600-LRH	60	100	0.15	800
FB201209A800-LRH	80	100	0.15	800
FB201209A121-LRH	120	100	0.15	800
FB201209A221-LRH	220	100	0.20	500
FB201209A301-LRH	300	100	0.20	500
FB201209A601-LRH	600	100	0.30	500
FB201209A102-LRH	1000	100	0.35	300
FB201209A202-LRH	2000	100	0.50	200

TEST INSTRUMENT: HP4291B、HP4338A/B、HP6632B、Agilent 8720ES

TEST LEVEL: 250 mV

SPECIFICATION FOR APPROVAL

4. ELECTRICAL CURVE

FB201209A300-LRH

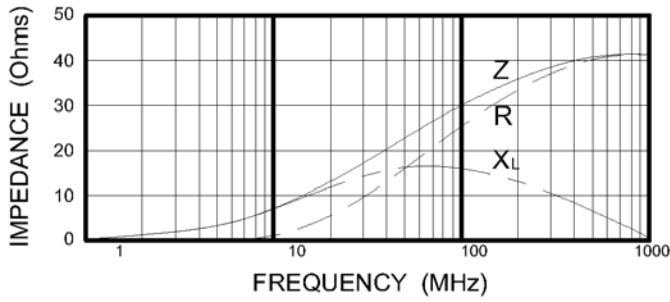

FB201209A400-LRH

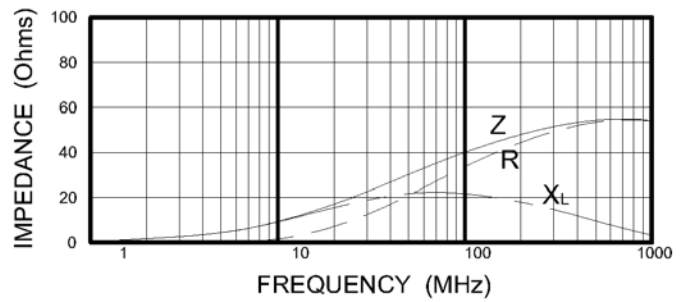

FB201209A600-LRH

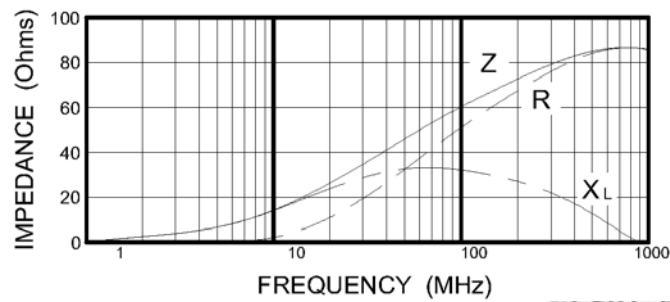

FB201209A800-LRH

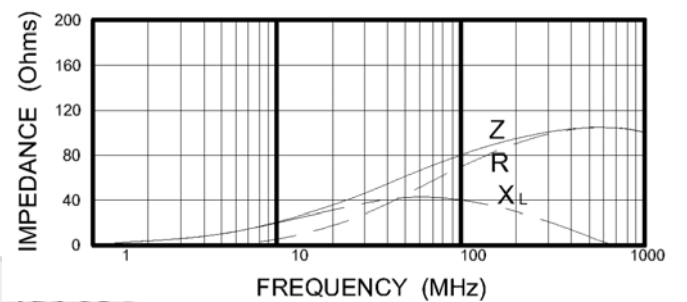

FB201209A121-LRH

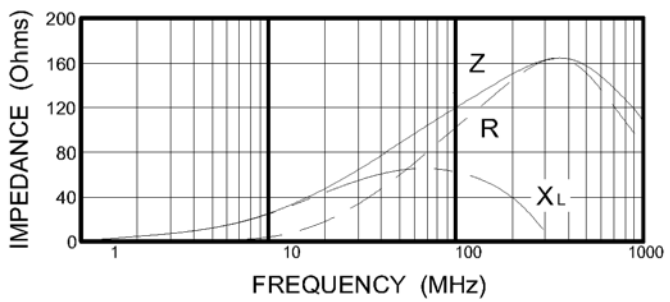

FB201209A221-LRH

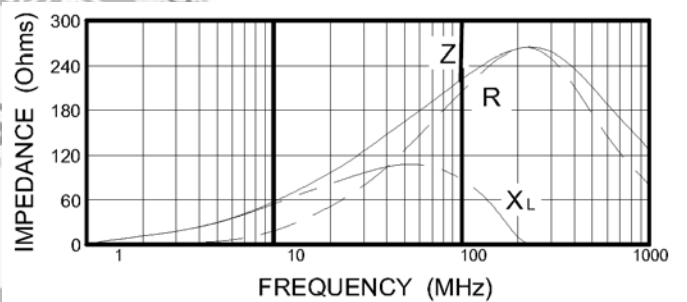

FB201209A301-LRH

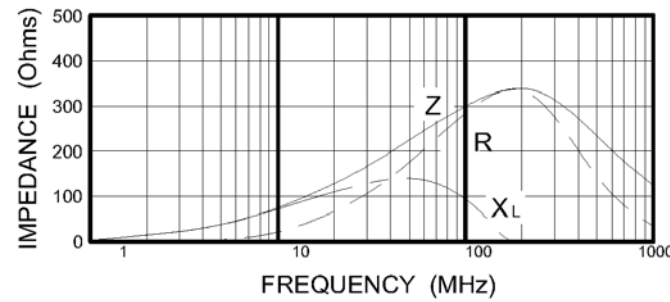

FB201209A601-LRH

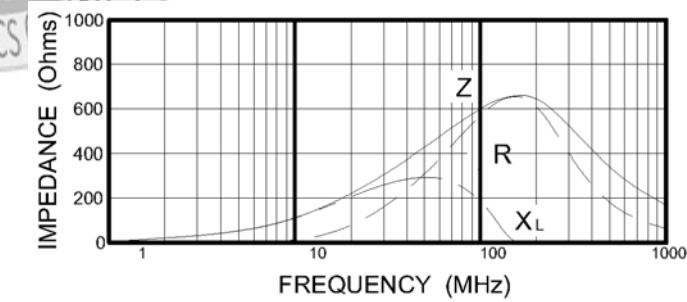

FB201209A102-LRH

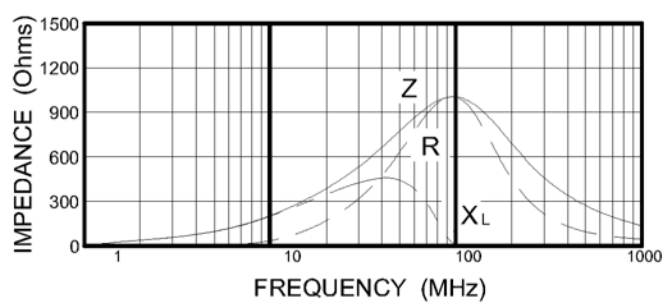

FB201209A202-LRH

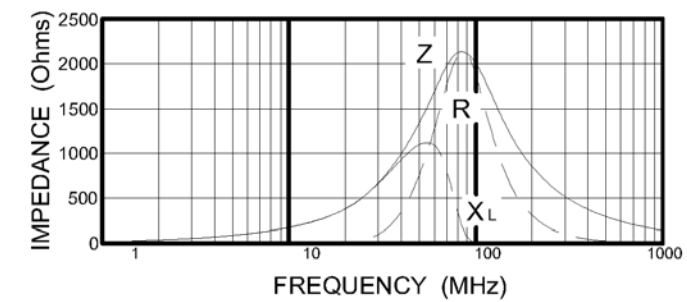

SPECIFICATION FOR APPROVAL

5. RELIABILITY PERFORMANCE

Test Item	Test Condition	Criteria
Temperature Cycle	a. Temperature : -40 ~ +85°C b. Cycle : 100 cycles c. Dwell time : 30 minutes d. Measurement : at ambient temperature 24 hrs after test completion	a. No mechanical damage b. Impedance value should be within ±20% of the initial value
Operational Life	a. Temperature : 125°C±5°C b. Test time : 1000 hrs c. Apply current : full rated current d. Measurement : at ambient temperature 24 hrs after test completion	a. No mechanical damage b. Impedance value should be within ±20% of the initial value
Biased Humidity	a. Temperature : 40°C±2°C b. Humidity : 90 ~ 95 % RH c. Test time : 1000 hrs d. Apply current : full rated current e. Measurement : at ambient temperature 24 hrs after test completion	a. No mechanical damage b. Impedance value should be within ±20% of the initial value
Resistance to Solder Heat	a. Solder temperature : 260±5°C b. Flux : Rosin c. DIP time : 10±1 sec	a. More than 95% of terminal electrode should be covered with new solder b. No mechanical damage c. Impedance value should be within ±20% of the initial value
Adhesive Test	a. Reflow temperature : 245°C It shall be Soldered on the substrate applying direction parallel to the substrate b. Apply force(F) : 5 N c. Test time : 10 sec	a. No mechanical damage b. Soldering the products on PCB after the pulling test force > 5 N
Steam Aging Test	a. Temperature : 93°C b. Test time : 4 hrs (MCB1005) Others : 8 hrs c. Solder temperature : 235±5°C d. Flux : Rosin e. DIP time : 5±1 sec	More than 95% of terminal electrode should be covered with new solder
Rated Current Test	a. Apply current : full rated current / 5min	Temperature rise should be less than 25°C

OPERATING TEMPERATURE RANGE : - 55°C ~ +125°C

STORAGE CONDITION : LESS THAN 40°C & 70% RH

SPECIFICATION FOR APPROVAL

6. TYPICAL RoHS REFLOW PROFILE

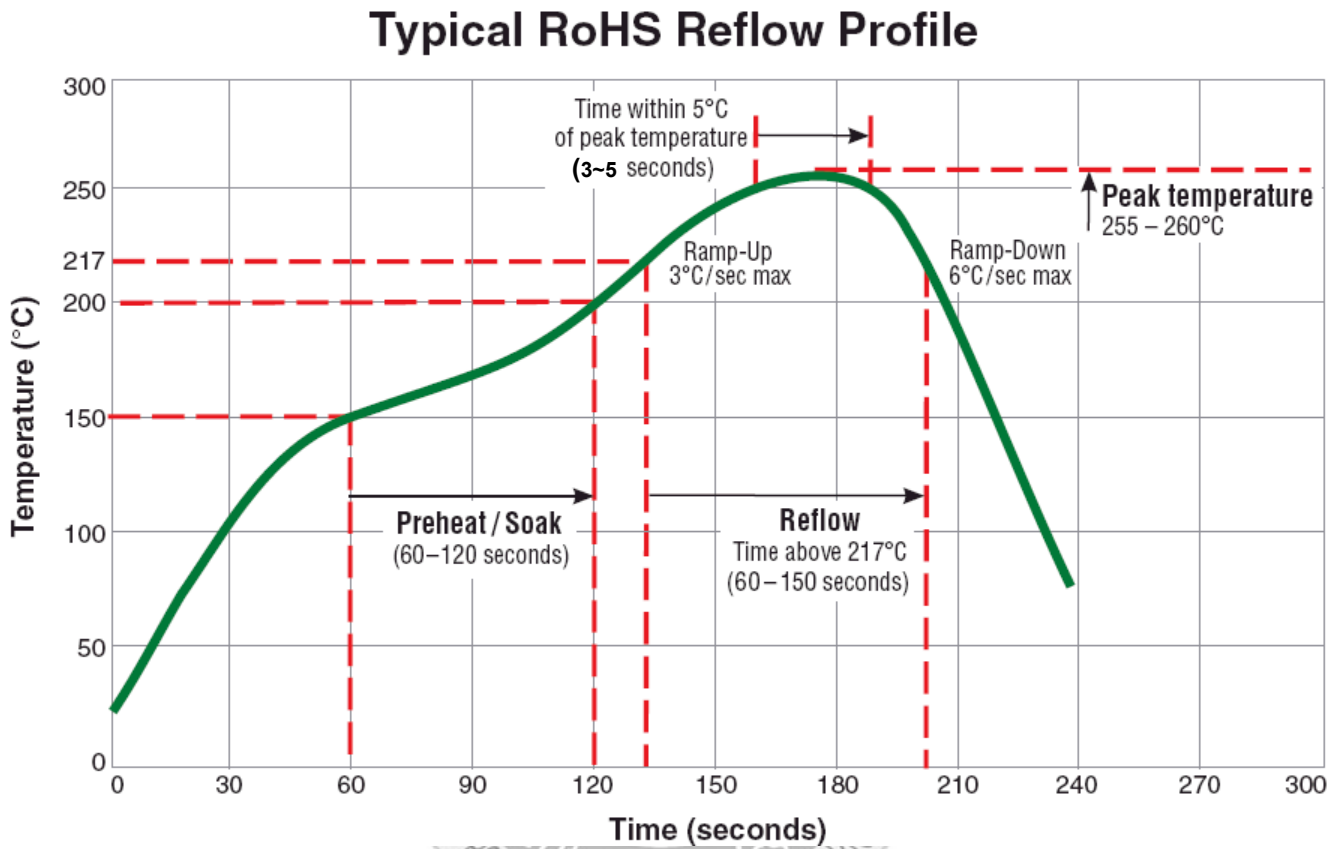

SPECIFICATION FOR APPROVAL

7. PACKING

7.1 PAPER CARRIER

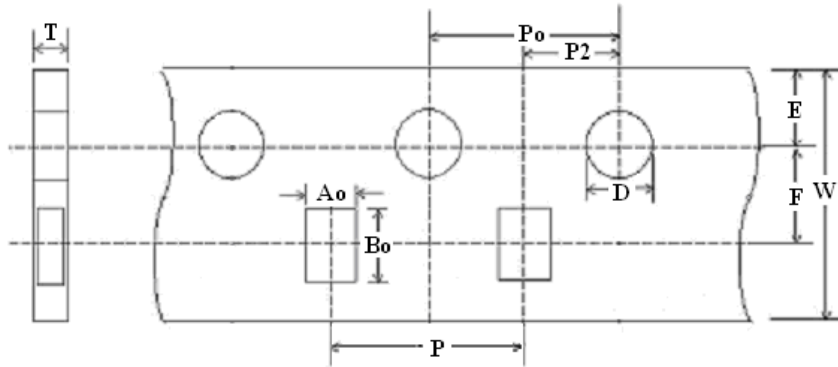

UNIT : mm

W	P	E	F	D	P ₀	P ₂	A _o	B _o	T
8.00±0.10	4.00±0.10	1.75±0.10	3.50±0.10	1.56±0.10	4.00±0.10	2.00±0.10	1.50±0.05	2.30±0.05	0.95±0.05

7.2 REEL DIMENSIONS

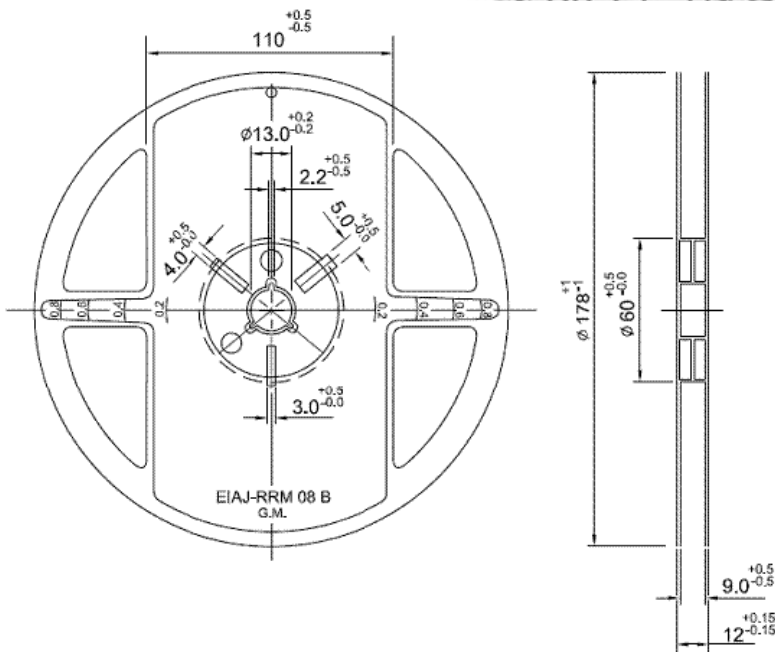

7.3 Packaging Quantity

Reel	Inner Box
4,000 Pcs	5 Reels