

SPECIFICATION FOR APPROVAL

CUSTOMER	_____
CUST. PART NO.	_____
CUST. DOC. REV.	_____
DESCRIPTION	CHIP INDUCTORS(RoHS+H.F.)
SAMPLE LOT NO.	_____
PART NO.	FL201209L-XXXM-LRH
DOC. REV.	ORIG
DATE	_____

Once you approve this part, please sign and return this page to the following marked location.

Customer Signature: _____ Date: _____

This part currently development section. Production line can produce this series of products.

Sales Office-Headquarter
 No. 566-1, Kao-Shi Rd., Yangmei, Taoyuan 32668, Taiwan
 TEL: +886-3-475-3355
 FAX: +886-3-485-4959

Yong Zhou Plant
 Tao-Yuan Rd., Fenghuang Park, Lengshuitan District, Yongzhou, Hunan 425000, P.R.C.
 TEL: +86-746-8610-180
 FAX: +86-746-8610-181

Sales Office-Dong Guan,China
 No.638,Mei Jing West Road Xiniupo Administrative Zone Dalang Town,Dong Guan City,GuangDong Province,China.
 TEL: +86-769-8555-0979
 FAX: +86-769-8555-0972

TESTED BY	CHECKED BY	APPROVED BY

TABLE OF CONTENTS

INDEX	Page
■ Engineering Change Notice – Record	2
■ Part Number Identification	3
■ Mechanical Dimension	3
■ Rating Temperature	3
■ Test Instrument	3
■ Electrical Specification	3
■ Electrical Curve	4
■ Reliability Performance	5
■ Reflow Chart	6
■ Packing	7
■ Test Report	

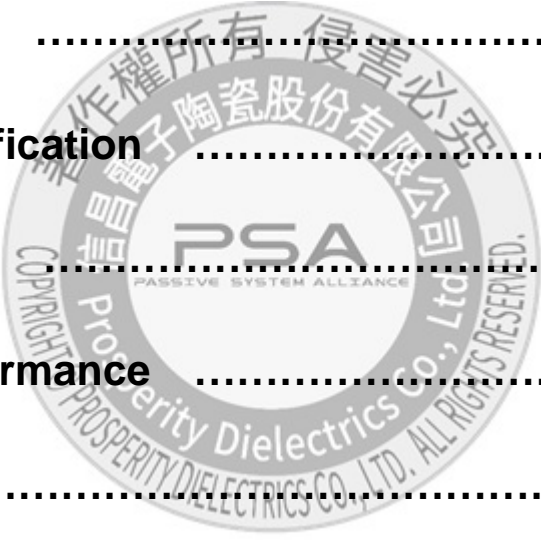

SPECIFICATION FOR APPROVAL

CUSTOMER	CUSTOMER P/N	REV. -	SPL. LOT NO.	
PART NAME CHIP INDUCTORS (RoHS+H.F.)	PART NO. FL201209L-XXXM-LRH	REV. ORIG	DATE OF ISSUE	Q'TY 0 PCS

ENGINEERING CHANGE NOTICE – RECORD

REVISION NO.	REVISION DESCRIPTION	AUTHOR	DATE	REMARK
ORIG		<i>Bruce Hsu</i>		



SPECIFICATION FOR APPROVAL

※This is a RoHS and REACH compliant product whose related documents are available on request.

※Graphic is only for dimensionally application.

1. PART NUMBERING IDENTIFICATION

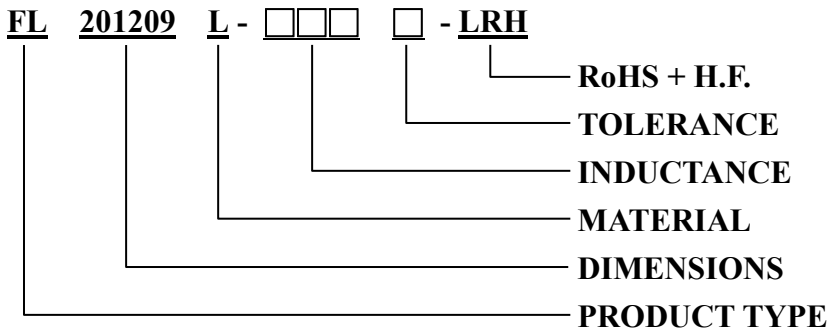

2. MECHANICAL DIMENSION

UNIT: mm

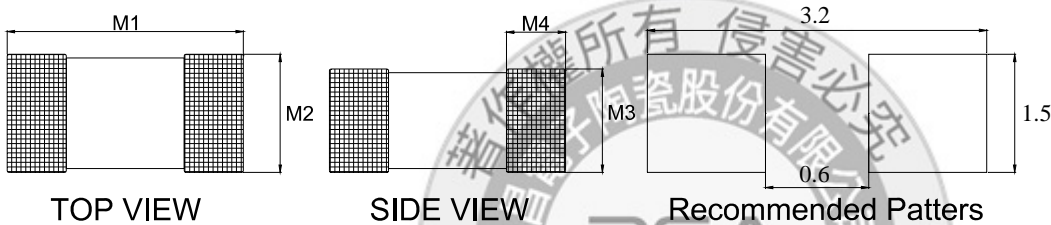

	DIM.	TOL.
M1	2.00	±0.15
M2	1.25	±0.15
M3	0.90	±0.10
M4	0.50	±0.20

3. RATING TEMPERATURE

OPERATING TEMPERATURE RANGE: - 40°C ~ +85°C

STORAGE CONDITION : LESS THAN 40°C AND 70% RH

STORAGE TIME: 12 MONTHS MAX.

4. TEST INSTRUMENT

4-1. HP4291B-RF Impedance / Material Analyzer

4-2. HP4338A/B Milliohm meter

4-3. OSC Level: 100mV

5. ELECTRICAL SPECIFICATION

Part number	Inductance (μH)	Test Frequency (MHz)	SRF (MHz) MIN.	DC Resistance (Ω) ±25%	Rated Current (mA)
FL201209L-R47M-LRH	0.47	1	100	0.075	1300
FL201209L-1R0M-LRH	1.00	1	50	0.100	900
FL201209L-2R2M-LRH	2.20	1	40	0.230	800
FL201209L-4R7M-LRH	4.70	1	40	0.230	800

NOTE:

Tolerance: M:±20%

SPECIFICATION FOR APPROVAL

6. ELECTRICAL CURVE

Inductance vs. Frequency

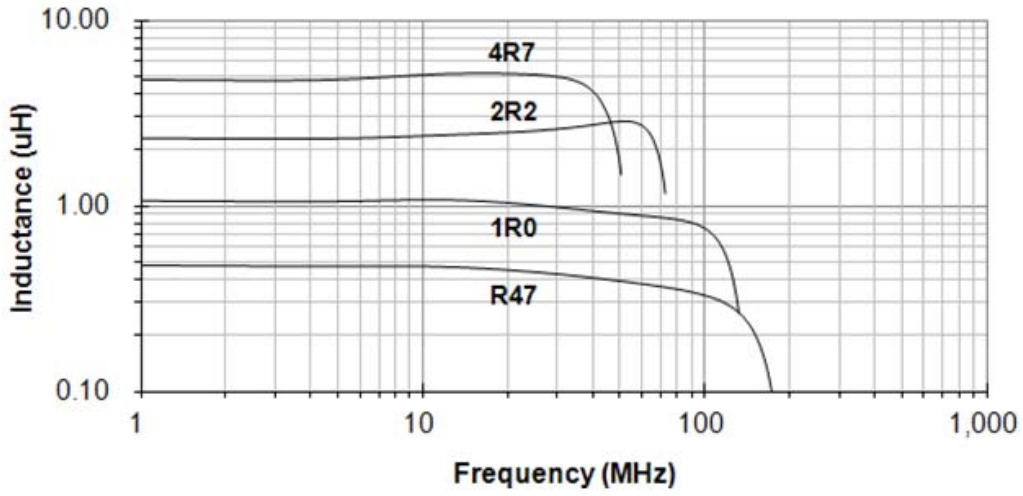

Inductance vs. DC-bias

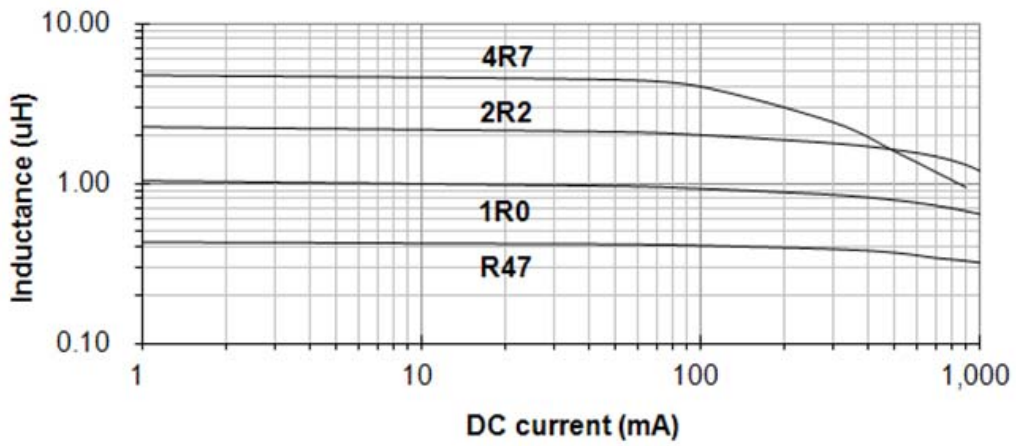

Temperature rise vs. DC-bias

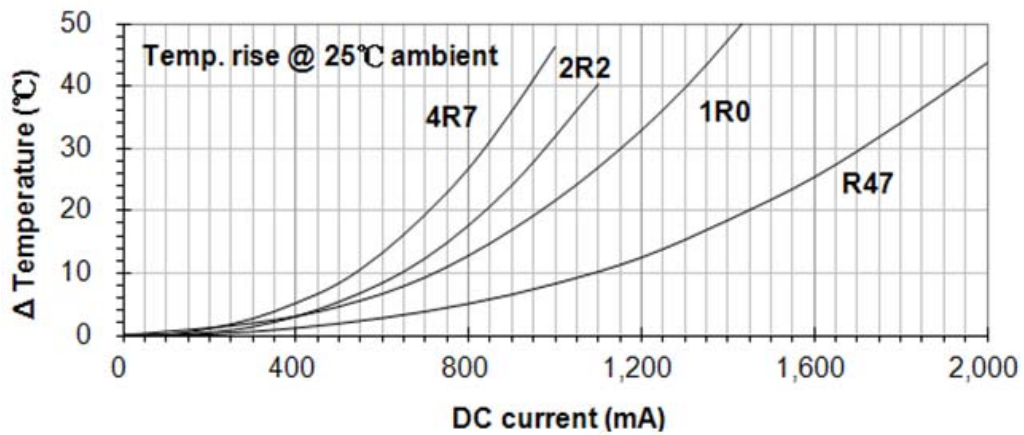

SPECIFICATION FOR APPROVAL

7. RELIABILITY PERFORMANCE

Item	Test Condition	Requirements
Resistance to Solder Heat	<ol style="list-style-type: none"> 1. Solder temperature: 260±5°C 2. Flux: Rosin 3. DIP time: 10±1 sec 	<ol style="list-style-type: none"> 1. More than 95% of terminal electrode should be covered with new solder 2. No mechanical damage 3. Inductance value should be within ±20% of the initial value
Solderability	<ol style="list-style-type: none"> 1. Solder temperature: 235±5°C 2. Flux: Rosin 3. DIP time: 5±1 sec 	<ol style="list-style-type: none"> 1. More than 95 % of terminal electrode should be covered with new solder 2. No mechanical damage
Adhesive Test	<ol style="list-style-type: none"> 1. Reflow temperature: 245°C It shall be Soldered on the substrate applying direction parallel to the substrate 2. Apply force(F): 5 N 3. Test time: 10 sec 	<ol style="list-style-type: none"> 1. No mechanical damage 2. Soldering the products on PCB after the pulling test force > 5 N
Temperature Cycle	<ol style="list-style-type: none"> 1. Temperature:-40 ~ 85°C For 30 minutes each 2. Cycle: 100 cycles 3. Measurement: At ambient temperature 24 hours after test completion 	<ol style="list-style-type: none"> 1. No mechanical damage 2. Inductance should be within ±20% of the initial value (Inductance: ≤0.47μH) Inductance should be within ±30% of the initial value (Inductance: >0.47μH)
High Temperature Resistance	<ol style="list-style-type: none"> 1. Temperature: 85±5°C 2. Testing time: 1000 hrs 3. Measurement: at ambient temperature 24 hours after test completion 	<ol style="list-style-type: none"> 1. No mechanical damage 2. Inductance should be within ±20% of the initial value (Inductance: ≤0.47μH) Inductance should be within ±30% of the initial value (Inductance: >0.47μH)
Humidity	<ol style="list-style-type: none"> 1. Temperature: 40°C±2°C 2. Humidity: 90-95 % RH 3. Testing time: 1000 hrs 4. Measurement: At ambient temperature 24 hours after test completion 	<ol style="list-style-type: none"> 1. No mechanical damage 2. Inductance should be within ±20% of the initial value
Rated Current	At ambient temperature & humidity Testing time:5 minutes (under full rated current)	Product surface temp: below room temperature plus 40°C

SPECIFICATION FOR APPROVAL

8. TYPICAL RoHS REFLOW PROFILE

Typical RoHS Reflow Profile

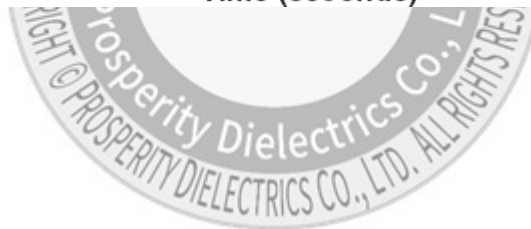
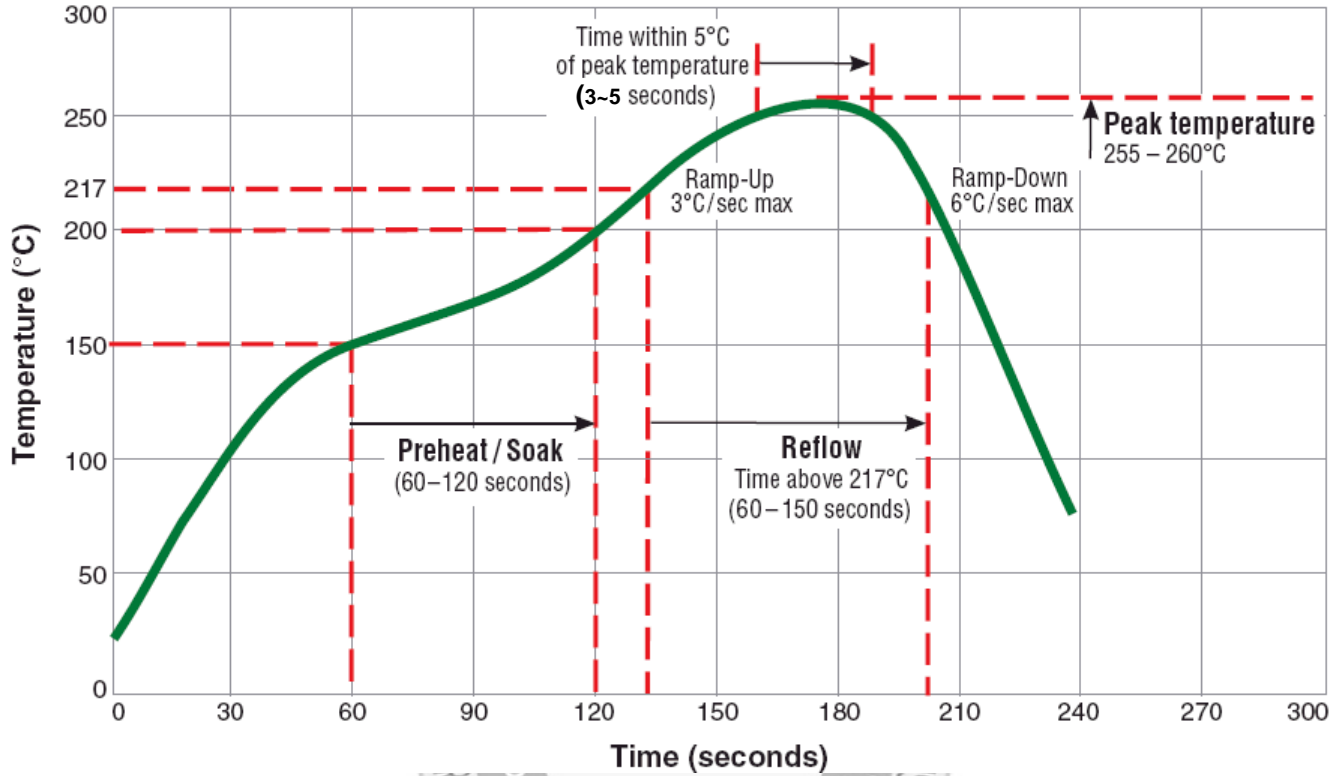

SPECIFICATION FOR APPROVAL

9. PACKING

9-1. Plastic Carrier

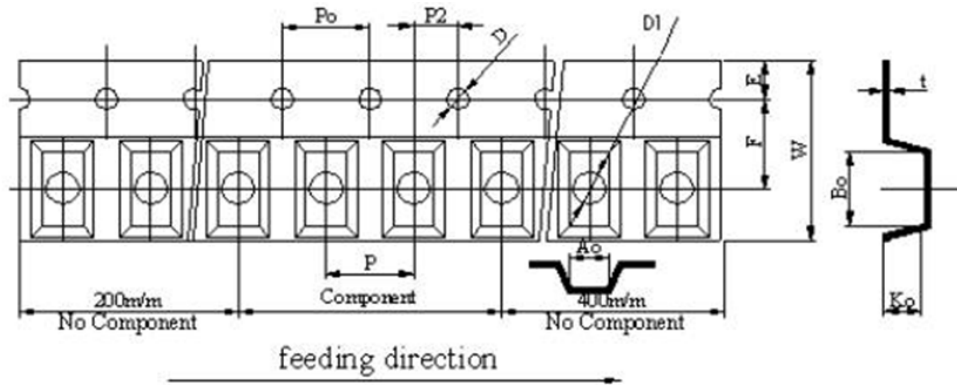

UNIT: mm

W	P	E	F	D	D1	Po	P2	Ao	Bo	Ko	t
8.00±0.10	4.00±0.10	1.75±0.10	3.50±0.10	1.55±0.05	1.00±0.05	4.00±0.10	2.00±0.10	1.40±0.10	2.30±0.10	1.13±0.10	0.22±0.05

9-2. Reel Dimension (UNIT: mm)

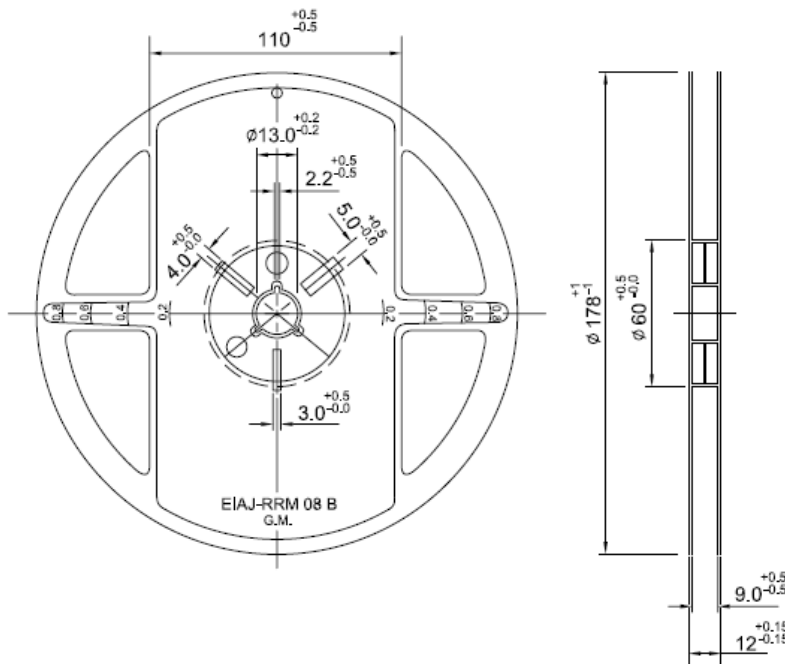

9-3. Packaging Quantity

Qty.	Inner Box
3000 Pcs	5 Reels