

# SPECIFICATION FOR APPROVAL

※This is a RoHS and REACH compliant product whose related documents are available on request.  
 ※Graphic is only for dimensionally application.

## 1. PART NUMBERING IDENTIFICATION

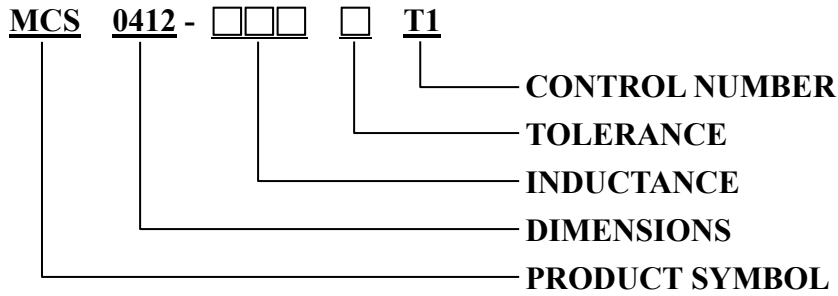

## 2. MECHANICAL DIMENSION

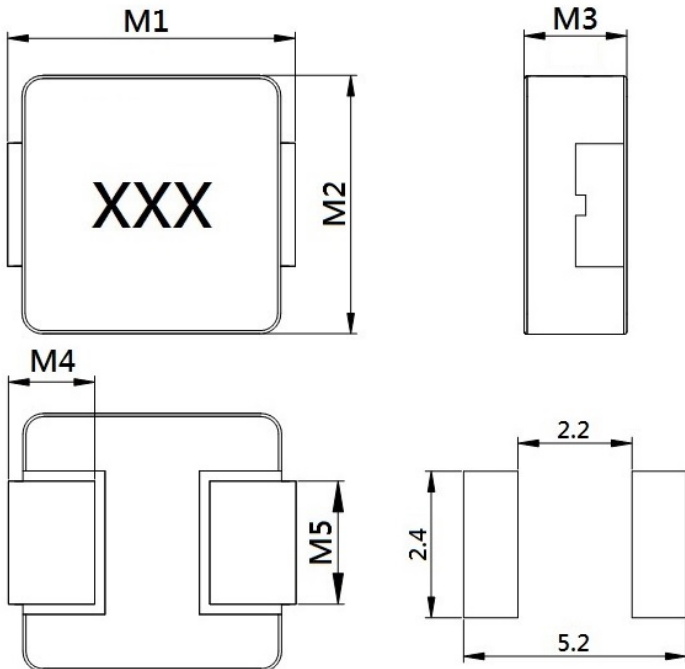

UNIT: mm

	DIM.	TOL.
M1	4.45	±0.25
M2	4.06	±0.25
M3	1.00	±0.20
M4	0.76	±0.30
M5	2.00	±0.20

Recommended Patterns

## 3. MARKING

Marking ex: 1.0uH → 1R0

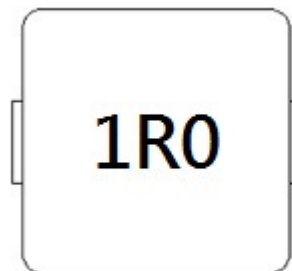

# SPECIFICATION FOR APPROVAL

## 4. ELECTRICAL SPECIFICATION

Part Number	Inductance (uH)	DC Resistance (mΩ) Typical	DC Resistance (mΩ) MAX.	I rms (A) Typical	I rms (A) MAX.	I sat (A) Typical	I sat (A) MAX.
MCS0412-R10NT1	0.10	4.3	5.5	11.5	10.0	25.0	22.0
MCS0412-R15NT1	0.15	5.5	6.8	10.0	9.0	21.5	19.0
MCS0412-R22MT1	0.22	6.6	8.0	8.5	7.5	20.0	17.0
MCS0412-R33MT1	0.33	13.6	16.0	7.0	6.0	11.0	9.0
MCS0412-R36MT1	0.36	15.5	18.0	6.5	5.5	8.5	7.0
MCS0412-R47MT1	0.47	18.0	20.0	6.0	5.0	6.5	5.5
MCS0412-R60MT1	0.60	22.5	26.0	5.3	4.5	6.0	5.0
MCS0412-R68MT1	0.68	32.0	37.0	5.0	4.0	6.0	5.0
MCS0412-1R0MT1	1.00	41.0	47.0	4.0	3.5	6.0	5.0
MCS0412-1R2MT1	1.20	48.0	56.0	3.5	2.7	5.0	4.2
MCS0412-1R5MT1	1.50	55.0	63.3	3.0	2.4	4.0	3.2
MCS0412-2R2MT1	2.20	69.2	80.0	2.8	2.2	3.5	3.0
MCS0412-3R3MT1	3.30	84.0	97.0	2.3	2.0	3.0	2.7
MCS0412-4R7MT1	4.70	128.0	145.0	2.0	1.7	2.5	2.3
MCS0412-5R6MT1	5.60	180.0	208.0	1.7	1.5	2.3	2.0
MCS0412-6R8MT1	6.80	300.0	360.0	1.5	1.3	1.7	1.5
MCS0412-8R2MT1	8.20	313.0	376.0	1.4	1.1	1.6	1.4
MCS0412-100MT1	10.00	410.0	463.0	1.3	1.0	1.4	1.2
MCS0412-220MT1	22.00	950.0	1050.0	0.8	0.6	1.0	0.8

Tolerance: M:±20%, N:±30%

Note:

1. Test frequency: 100KHz/1.0V
2. Operating temperature: -40~+125°C (Including self - temperature rise)
3. Storage temperature:
  - 3-1. -10~+40°C, 50~60% RH (Product with taping)
  - 3-2. -40~+125°C (on board)
4. All test data referenced to 25°C ambient
5. Testing Instrument: Inductance: HP4284A, CH11025, CH3302, CH1320, CH1320S LCR Meter / DC Resistance: CH16502, Agilent33420A Micro ohm meter
6. Heat Rated Current (I<sub>rms</sub>) will cause the coil temperature rise approximately Δt of 40°C
7. Saturation Current (I<sub>sat</sub>) will cause L0 to drop approximately 30%
8. The part temperature (ambient + temp rise) should not exceed 125°C under worst case operating conditions. Circuit design, component, PCB trace size and thickness, airflow and other cooling provisions all affect the part temperature. Part temperature should be verified in the end application
9. MSL: Level 1

# SPECIFICATION FOR APPROVAL

## 5. ELECTRICAL CURVE

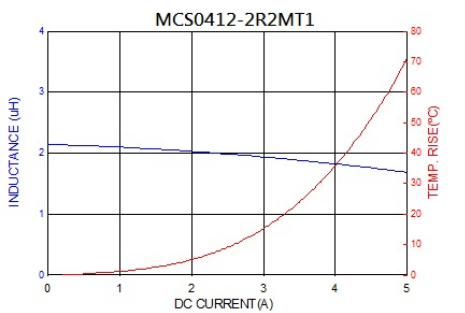
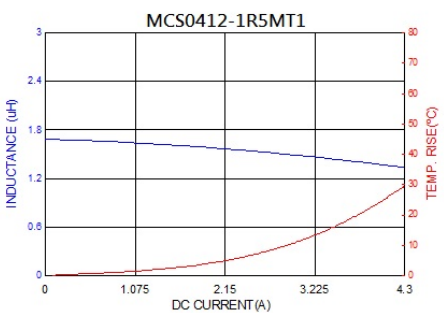
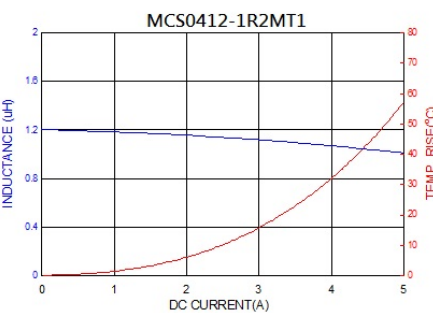
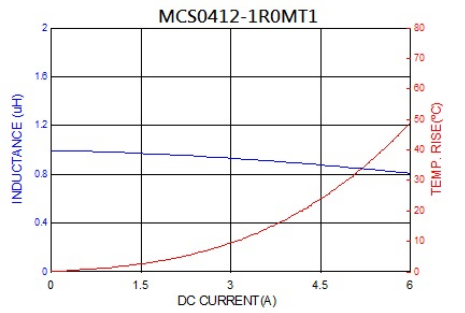
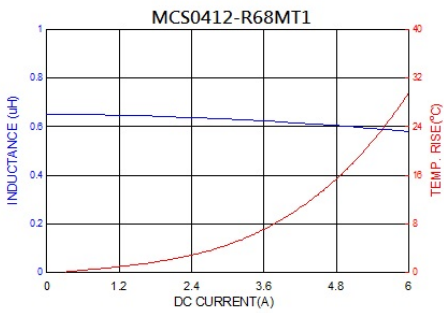
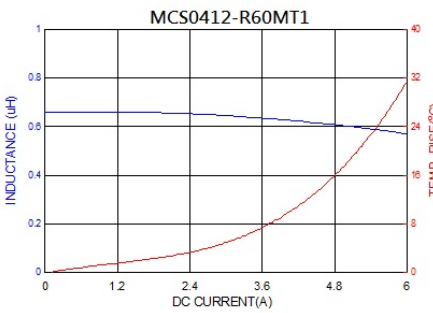
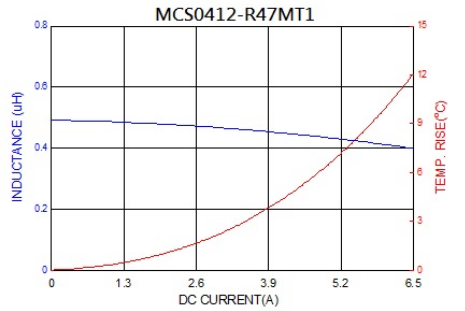
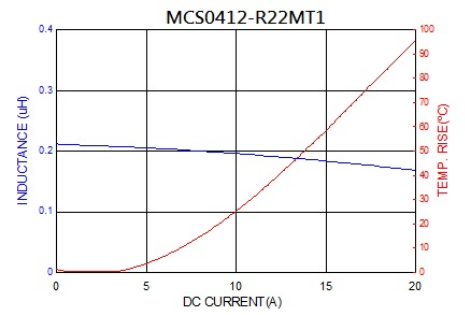
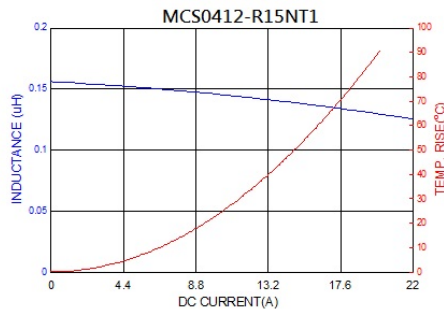
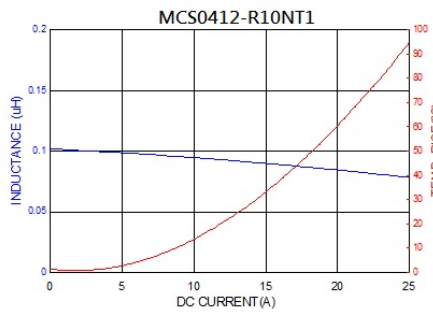

# SPECIFICATION FOR APPROVAL

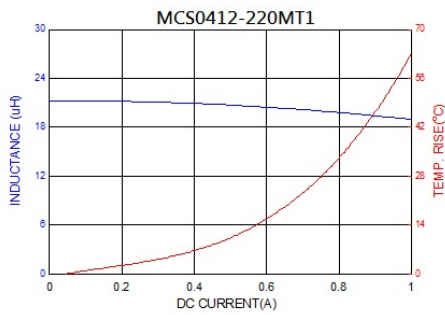
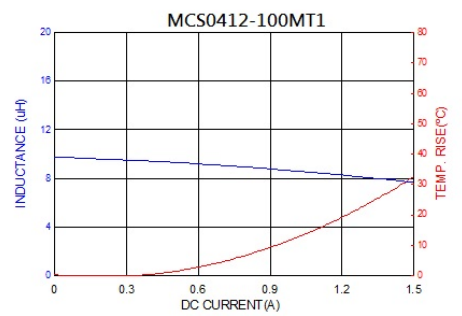
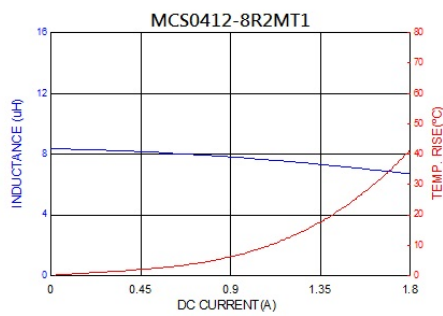
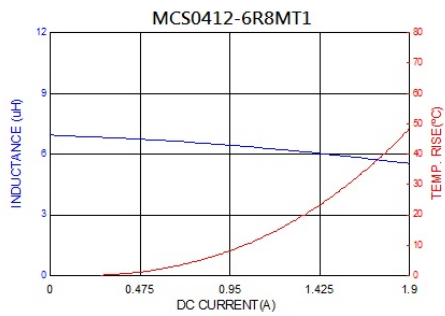
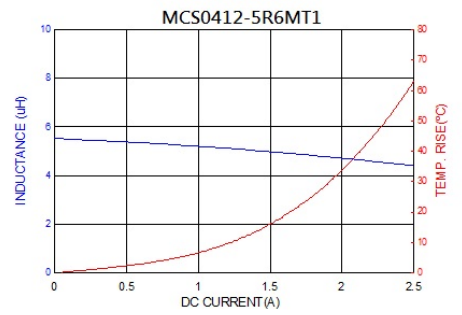
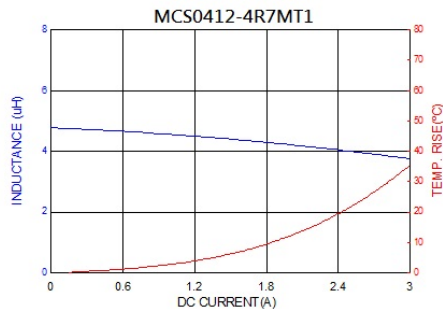
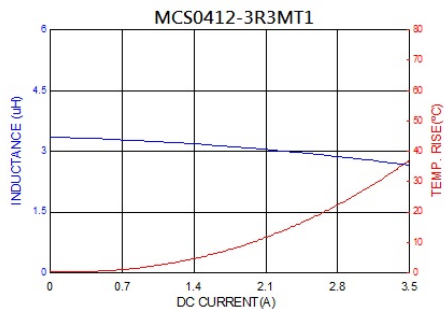

# SPECIFICATION FOR APPROVAL

## 6. PACKING

### 6-1 Reel Dimension

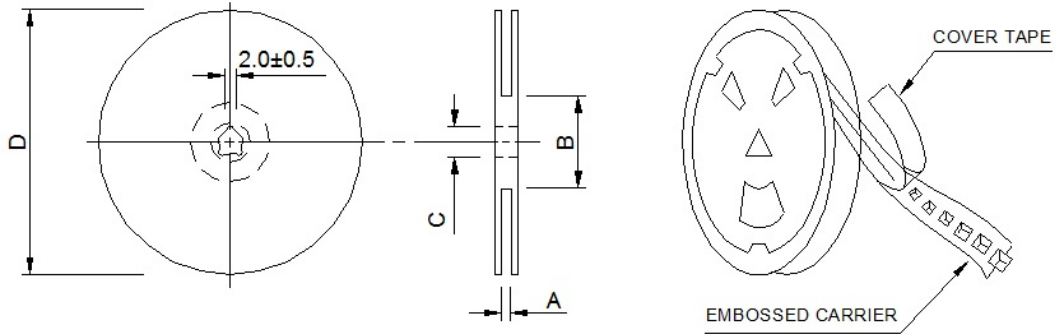

UNIT: mm

A	B	C	D
12.4+2/-0	100±2	13+0.5/-0.2	330

### 6-2 Tape Dimension

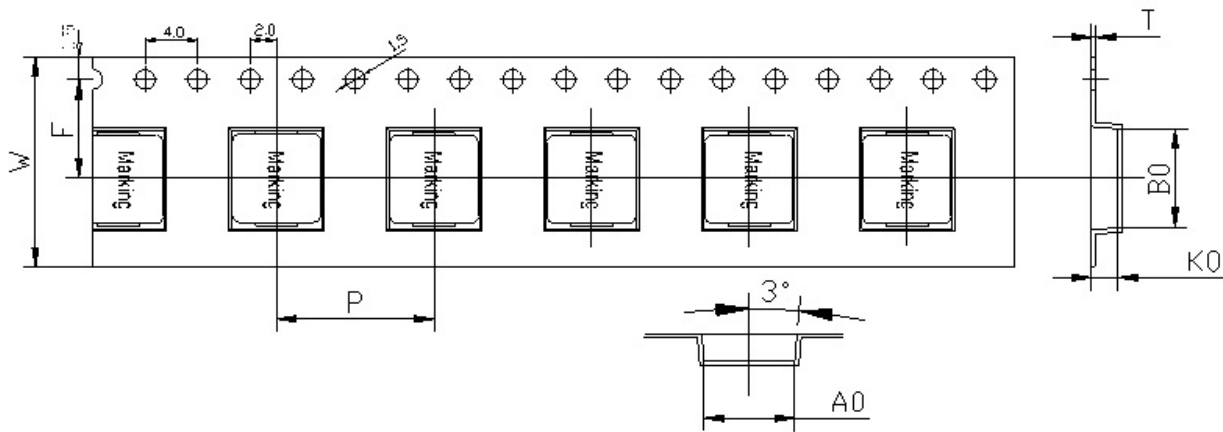

UNIT: mm

Bo	Ao	Ko	P	W	F	T
5.0±0.1	4.4±0.1	1.5±0.1	8.0±0.1	12±0.3	5.5±0.1	0.35±0.05

### 6-3 Tearing Off Force

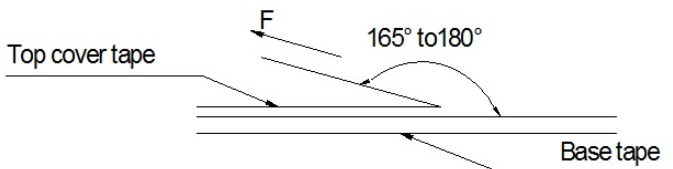

The force for tearing off cover tape is 10 to 130 grams in the arrow direction under the following conditions (referenced ANSI/EIA-481-D-2008 of 4.11 standard).

Room Temp. (°C)	Room Humidity (%)	Room atm (hPa)	Tearing Speed mm/min
5~35	45~85	860~1060	300

### 6-4 Packaging Quantity

Chip/Reel	4000
Inner box	8000
Carton	32000