

SPECIFICATION FOR APPROVAL

CUSTOMER	_____
CUST. PART NO.	_____
CUST. DOC. REV.	_____
DESCRIPTION	SMD CHIP BEAD(RoHS+H.F.)
SAMPLE LOT NO.	_____
PART NO.	TI160806PXXX-LRH
DOC. REV.	ORIG
DATE	_____

Once you approve this part, please sign and return this page to the following marked location.

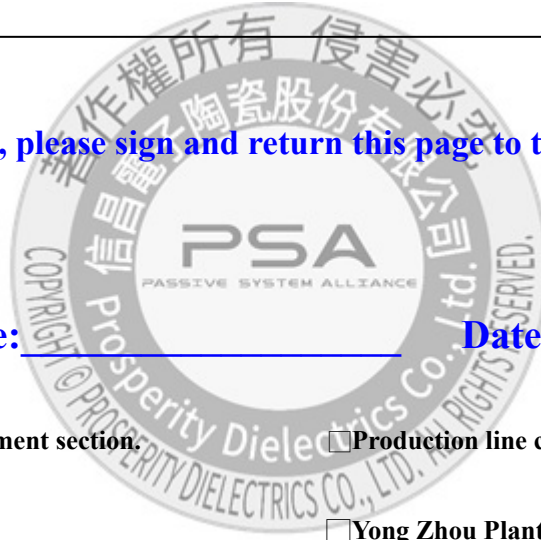

Customer Signature: _____ Date: _____

This part currently development section. Production line can produce this series of products.

Sales Office-Headquarter
No. 566-1, Kao-Shi Rd., Yangmei, Taoyuan 32668,
Taiwan
TEL: +886-3-475-3355
FAX: +886-3-485-4959

Yong Zhou Plant
Tao-Yuan Rd., Fenghuang Park, Lengshuitan
District, Yongzhou, Hunan 425000, P.R.C.
TEL: +86-746-8610-180
FAX: +86-746-8610-181

Sales Office-Dong Guan,China
No.638,Mei Jing West Road Xiniupo Administrative
Zone Dalang Town,Dong Guan City,GuangDong
Province,China.
TEL: +86-769-8555-0979
FAX: +86-769-8555-0972

TESTED BY	CHECKED BY	APPROVED BY

TABLE OF CONTENTS

INDEX	Page
■ Engineering Change Notice - Record	2
■ Part Number Identification	3
■ Mechanical Dimension	3
■ Electrical Specification	3
■ General Technical Data	4
■ Electrical Curve	5 ~ 6
■ Reliability Performance	7
■ Reflow Chart	8
■ Packing	9
■ Test Report	

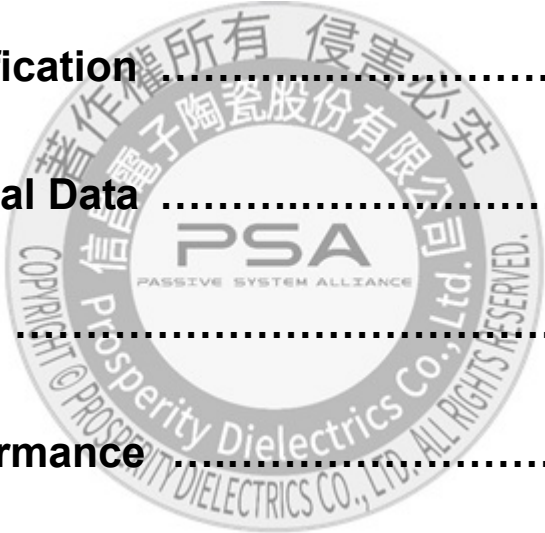

SPECIFICATION FOR APPROVAL

CUSTOMER	CUSTOMER P/N	REV. -	SPL. LOT NO.	
PART NAME SMD CHIP BEAD (RoHS+H.F.)	PART NO. TI160806PXXX-LRH	REV. ORIG	DATE OF ISSUE	Q'TY 0 PCS

ENGINEERING CHANGE NOTICE - RECORD

REVISION NO.	REVISION DESCRIPTION	AUTHOR	DATE	REMARK
ORIG		<i>Bruce Hsu</i>		



SPECIFICATION FOR APPROVAL

※This is a RoHS and REACH compliant product whose related documents are available on request.
 ※Graphic is only for dimensionally application.

1. PART NUMBER IDENTIFICATION

TI 160806 P □□□ - LRH

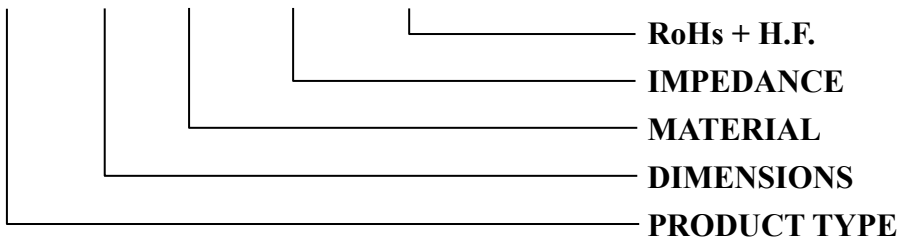

2. MECHANICAL DIMENSION

UNIT: mm

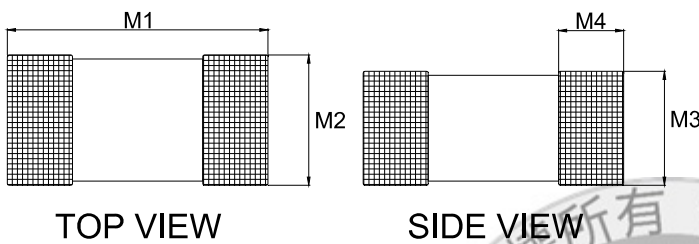

	DIM.	TOL.
M1	1.60	±0.15
M2	0.80	±0.15
M3	0.60	±0.15
M4	0.30	±0.20

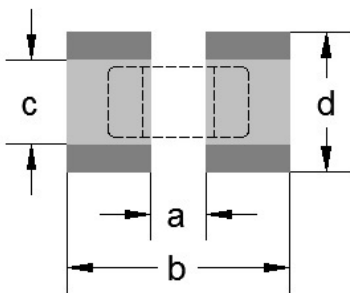

Rated current (A)	1.9~2.5	3~4	5~6	
a	0.70 ~ 0.80			
b	1.80 ~ 2.00			
c	0.70			
d	18um	1.3	2.5	6.5
	35um	0.8	1.3	3.4
	70um	0.7	0.7	1.65

3. ELECTRICAL SPECIFICATION

Part number	Impedance (Ω) ±25%	DC Resistance (Ω) MAX.	Rated Current (mA)	
			85℃	125℃
TI160806P260-LRH	26	0.007	6000	4000
TI160806P300-LRH	30	0.010	5000	3000
TI160806P700-LRH	70	0.022	3500	2000
TI160806P101-LRH	100	0.030	3000	1900
TI160806P121-LRH	120	0.030	3000	1900

TEST INSTRUMENT: HP4338A/B、Agilent E4991A、Agilent 16192A

TEST FREQUENCY: 100MHz

TEST LEVEL: 250 mV

SPECIFICATION FOR APPROVAL

4. GENERAL TECHNICAL DATA

In operating temperature exceeding +85°C, derating of current is set according to the operating temperature graph as follows.

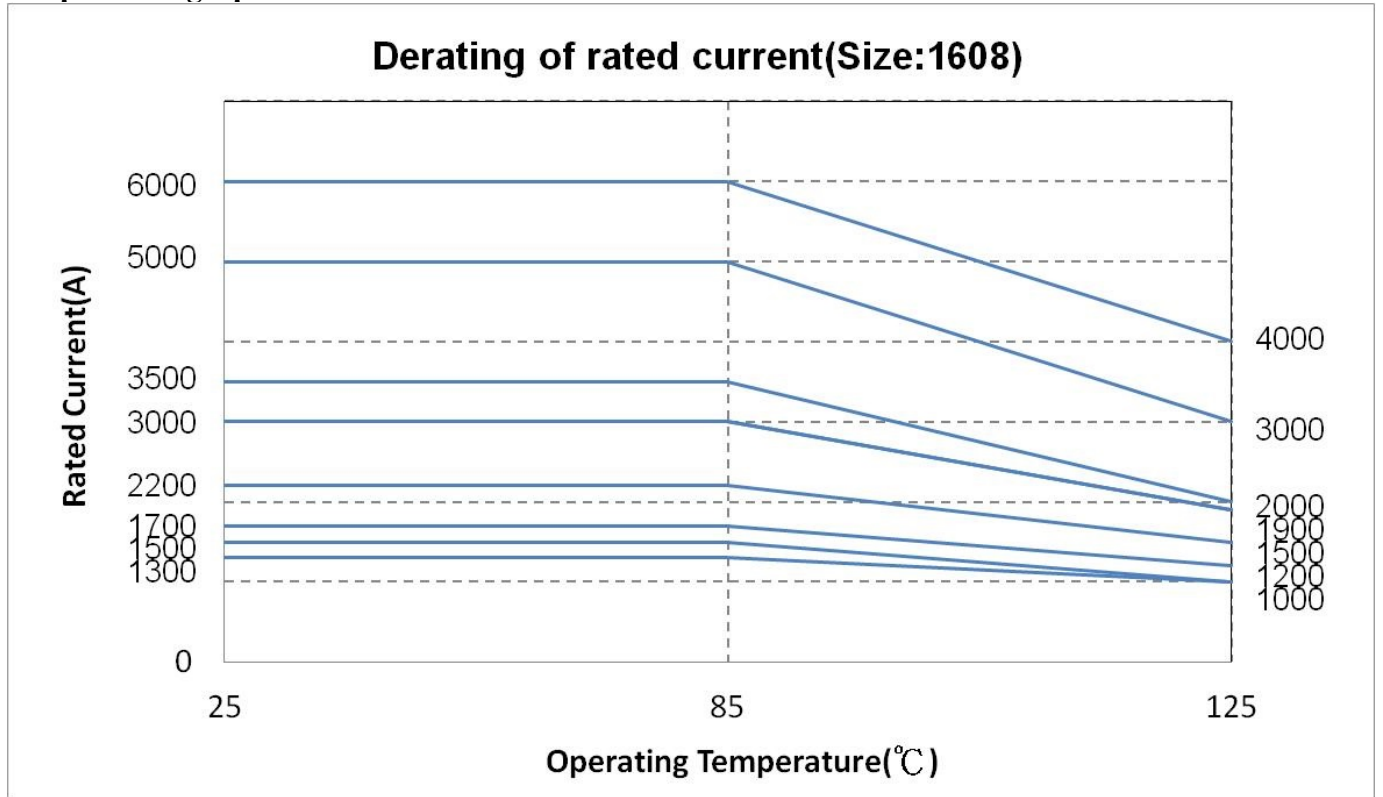

SPECIFICATION FOR APPROVAL

5. ELECTRICAL CURVE

TI160806P260-LRH

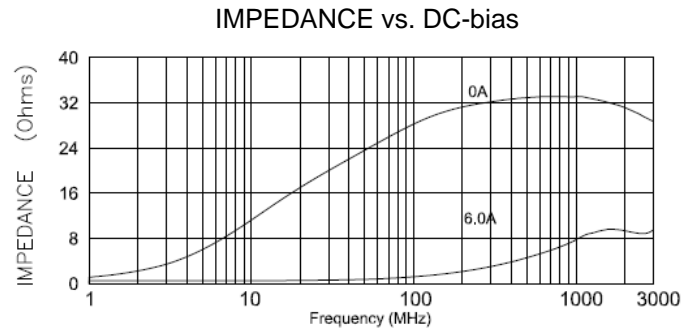
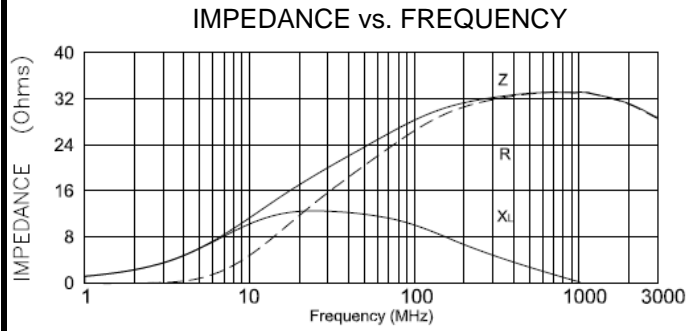

TI160806P300-LRH

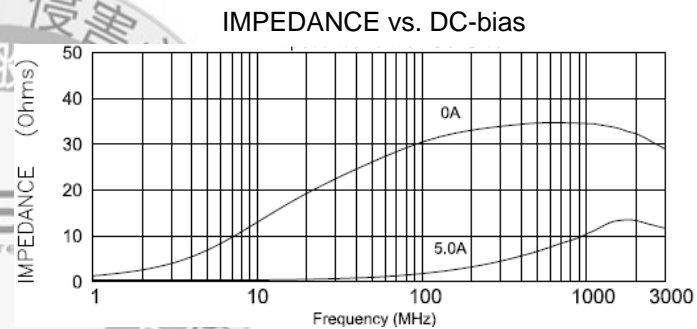
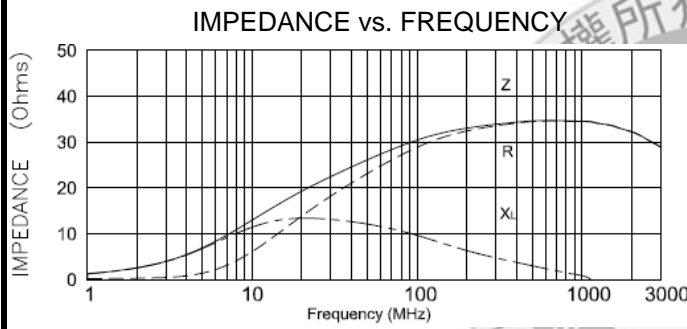

TI160806P700-LRH

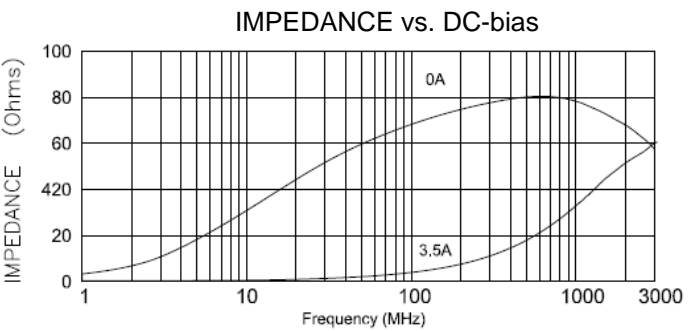
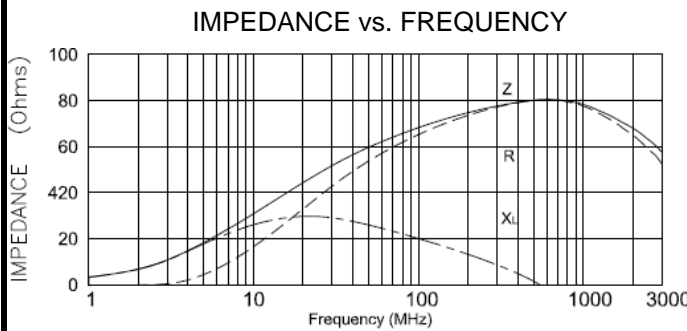

SPECIFICATION FOR APPROVAL

TI160806P101-LRH

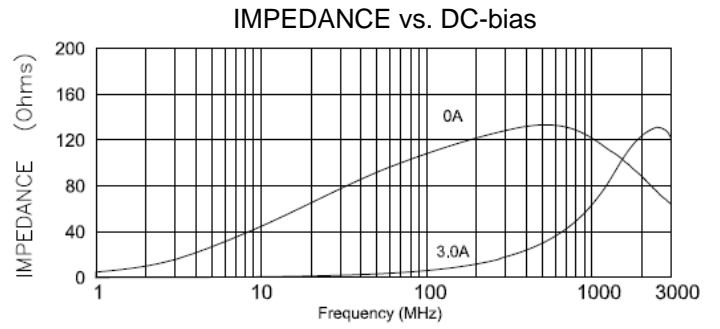
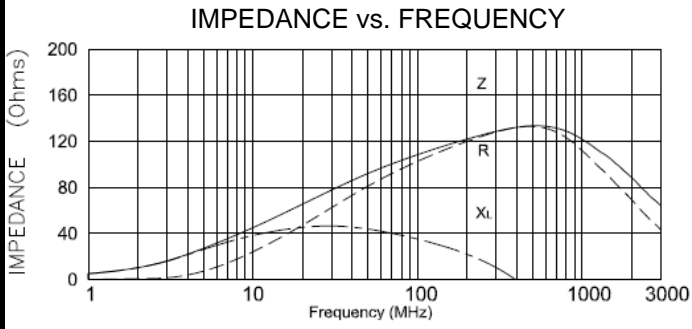

TI160806P121-LRH

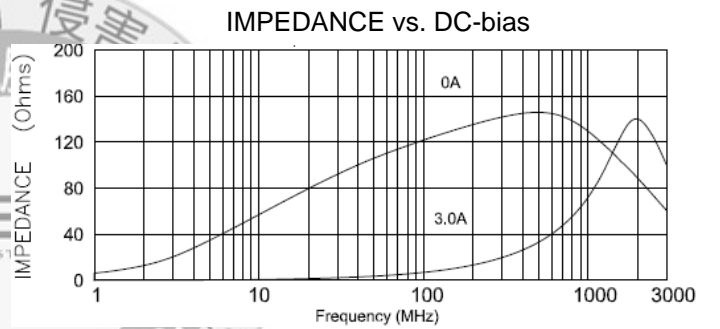
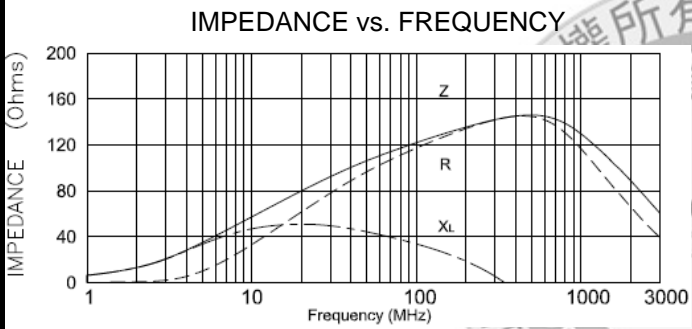

SPECIFICATION FOR APPROVAL

6. RELIABILITY PERFORMANCE

Test Item	Test Condition	Criteria
Temperature Cycle	<ol style="list-style-type: none"> 1. Temperature:-55 ~ 125°C For 30 minutes each 2. Cycle: 100 cycles 3. Measurement: at ambient temperature 24 hours after test completion 	<ol style="list-style-type: none"> 1. No mechanical damage 2. Impedance should be within $\pm 30\%$ of the initial value
Operational Life	<ol style="list-style-type: none"> 1. Temperature: 125\pm5°C 2. Testing time: 1000 hrs 3. Applied current: Full rated current 4. Measurement: At ambient temperature 24 hours after test completion 	<ol style="list-style-type: none"> 1. No mechanical damage 2. Impedance should be within $\pm 30\%$ of the initial value
Biased Humidity	<ol style="list-style-type: none"> 1. Temperature: 40°C\pm2°C 2. Humidity: 90-95 % RH 3. Applied current: Full rated current 4. Testing time: 1000 hrs 5. Measurement: at ambient temperature 24 hours after test completion 	<ol style="list-style-type: none"> 1. No mechanical damage 2. Impedance should be within $\pm 30\%$ of the initial value
Solderability	<ol style="list-style-type: none"> 1. Solder temperature : 235\pm5°C 2. Flux : Rosin 3. DIP time : 5\pm1 sec 	<ol style="list-style-type: none"> 1. More than 95% of terminal electrode should be covered with new solder 2. No mechanical damage
Resistance to Solder Heat	<ol style="list-style-type: none"> 1. Solder temperature : 260\pm5°C 2. Flux : Rosin 3. DIP time : 10\pm1 sec 	<ol style="list-style-type: none"> 1. More than 95% of terminal electrode should be covered with new solder 2. No mechanical damage 3. Impedance should be within $\pm 30\%$ of the initial value
Adhesive Test	<ol style="list-style-type: none"> 1. Reflow temperature : 245°C It shall be soldered on the substrate applying direction parallel to the substrate 2. Apply force(F) : 5 N (Size:0603:2N) Test time : 10 sec 	<ol style="list-style-type: none"> 1. No mechanical damage 2. Soldering the products on PCB after the pulling test force>5 N(Size:0603>2N)
Rated Current	At ambient temperature & humidity Testing time : 5 minutes (under full rated current)	Product surface temp : below room temperature plus 40°C

OPERATING TEMPERATURE RANGE : - 55°C ~ +125°C

STORAGE CONDITION : LESS THAN 40°C & 70% RH

SPECIFICATION FOR APPROVAL

7. TYPICAL RoHS REFLOW PROFILE

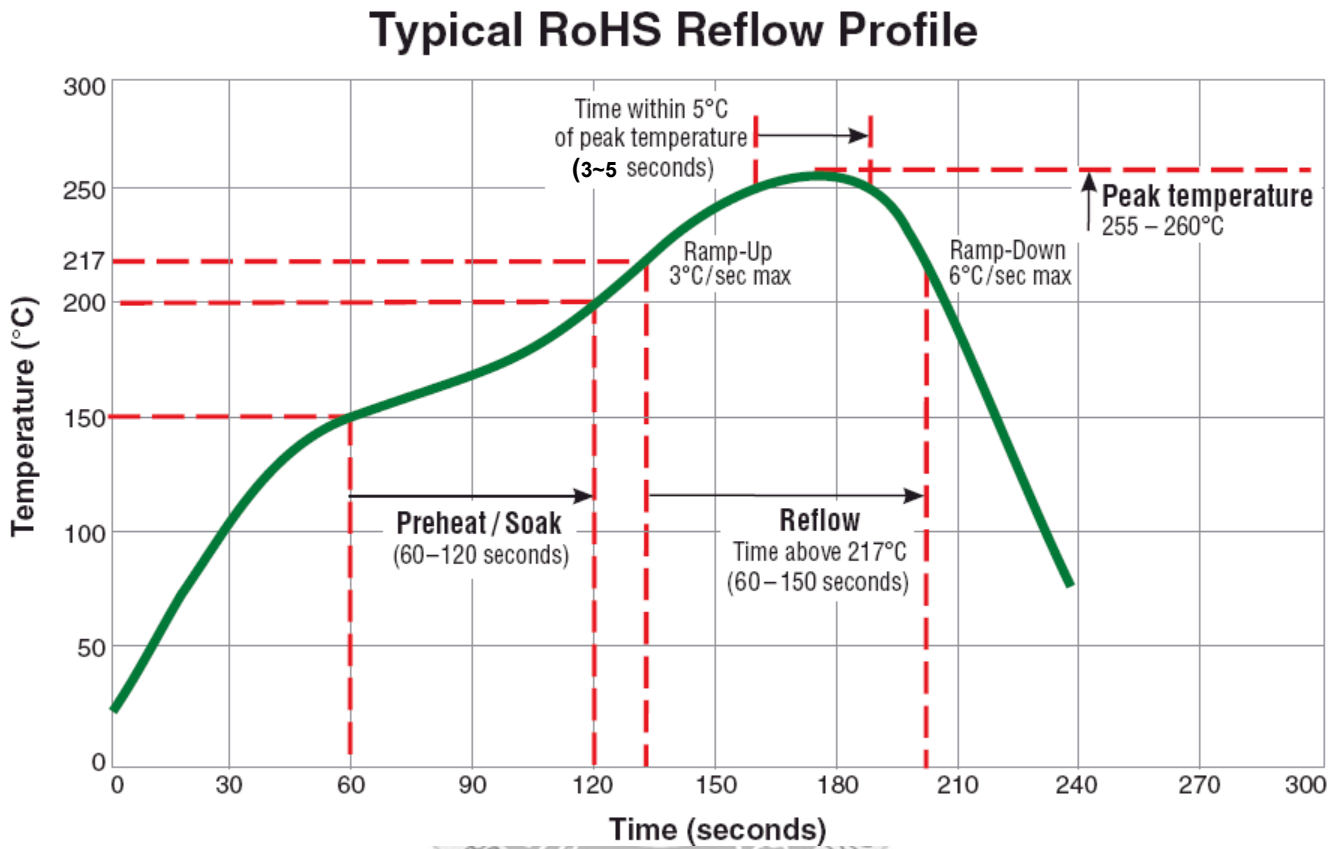

SPECIFICATION FOR APPROVAL

8. PACKING

8.1 PAPER CARRIER

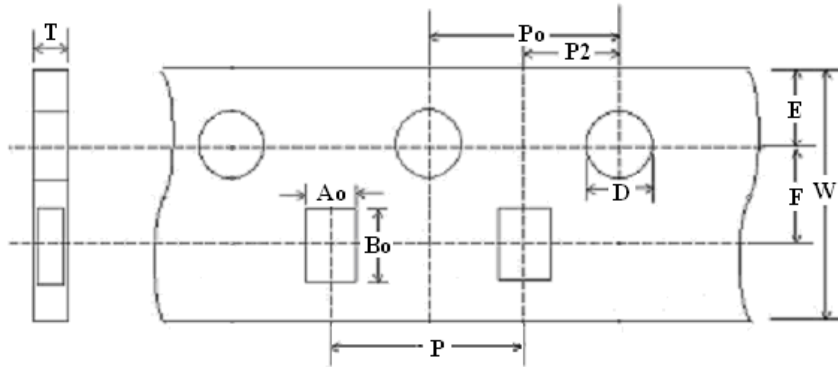

UNIT : mm

W	P	E	F	D	Po	P2	Ao	Bo	T
8.00±0.10	4.00±0.10	1.75±0.10	3.50±0.10	1.56±0.10	4.00±0.10	2.00±0.05	0.97±0.05	1.80±0.05	0.75±0.05

8.2 REEL DIMENSIONS

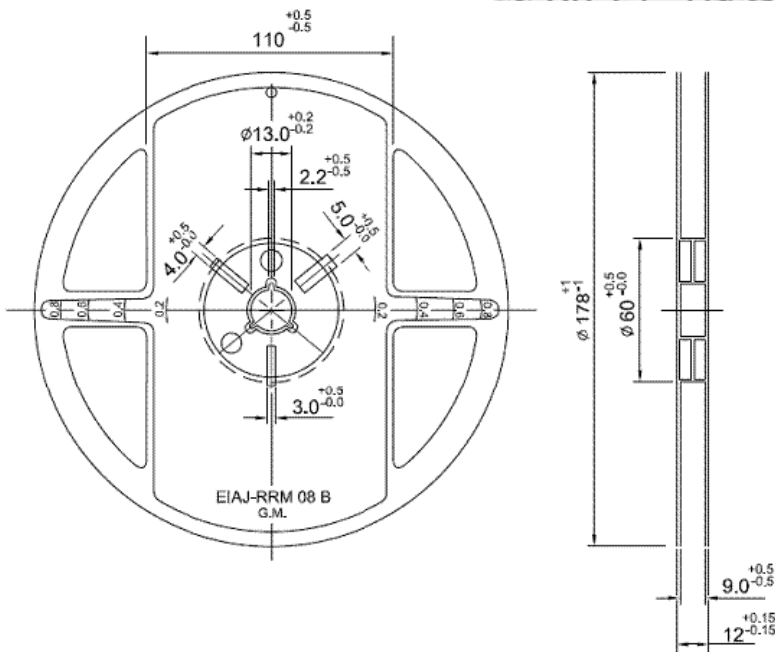

8.3 Packaging Quantity

Reel	Inner Box
4,000 Pcs	5 Reels