

# QUARTZ CRYSTAL



Series6L 308C SURFACE MOUNT PACKAGE FOR TUNING FORK 32.768KHz

---

Approved by:	
Checked by :	
Issued by:	

## SPECIFICATION

MODEL: SJK-6LC-32.768K-12.5-20-40-C

**深圳市晶科鑫实业有限公司**  
SHENZHEN CRYSTAL TECHNOLOGY INDUSTRIAL CO., LTD.

Add: RM#1805, East Wing, TianAn Hi-tech Plaza Phase2, TianAn Cyber Park, t, Shenzhen, China  
Tel: (86) 755 88352809 88352810 Fax: (86) 755 88353718 88352499  
E-mail: [jolly@q-crystal.com](mailto:jolly@q-crystal.com) HTTP://[www.q-crystal.com](http://www.q-crystal.com)



# QUARTZ CRYSTAL

Series6L 308C SURFACE MOUNT PACKAGE FOR TUNING FORK 32.768KHz

## FEATURE

- Wide Frequency range
- Small size
- Tape & Reel

## APPLICATIONS

- Microprocessor Systems
- Consumer Electronics

## ELECTRICAL SPECIFICATIONS FOR 308C

Frequency range	32. 768KHz
Frequency Tolerance (at 25°C)	±20ppm
ESR	40Kohm Max
Turnover Temperature	25 ± 5°C
Frequency Temperature Curve	-0.034(±0.006)ppm/°C <sup>2</sup>
Storage Temperature Range	-55 °C to +125 °C
Operable Temperature Range	-40 °C to + 85 °C
Shunt Capacitance (C0)	1.3pF Typ
Dynamic Capacitance (C1)	2.4fF Typ
Driver Level (Typical)	1 μW Max
Load Capacitance(C <sub>L</sub> )	12.5pF
Aging @25°C 1 <sup>st</sup> year (Max)	±3ppm, ±5ppm/year

**REMARK:** SPECIFICATIONS SUBJECT TO CHANGE WITHOUT PRIOR NOTICE. PLEASE CONFIRM WITH OUR SALES ENGINEER.

## PACKING AND DIMENSIONS

**308C Type** (unit:mm)

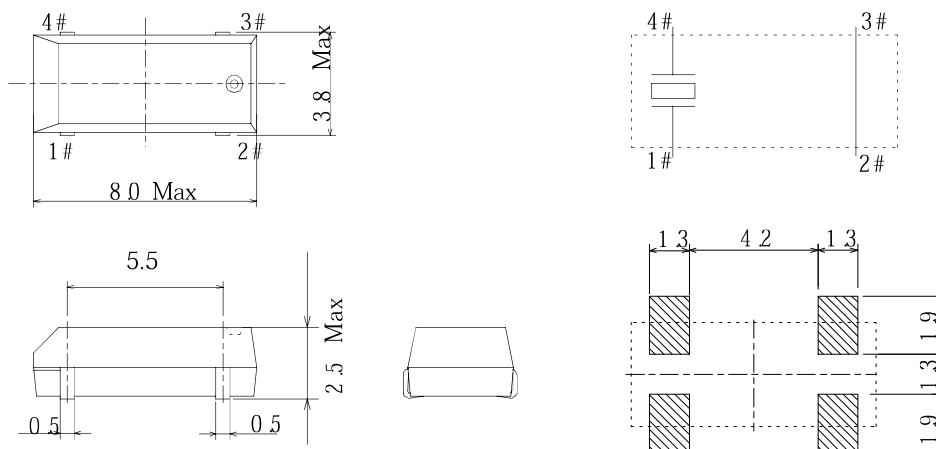

Add: RM#1805, East Wing, TianAn Hi-tech Plaza Phase2, TianAn Cyber Park, t, Shenzhen, China

Tel: (86) 755 88352809 88352810 Fax: (86) 755 88353718 88352499

E-mail: [jolly@q-crystal.com](mailto:jolly@q-crystal.com)

[HTTP://www.q-crystal.com](http://www.q-crystal.com)

# QUARTZ CRYSTAL



Series6L 308C SURFACE MOUNT PACKAGE FOR TUNING FORK 32.768KHz

## Tape for 308C

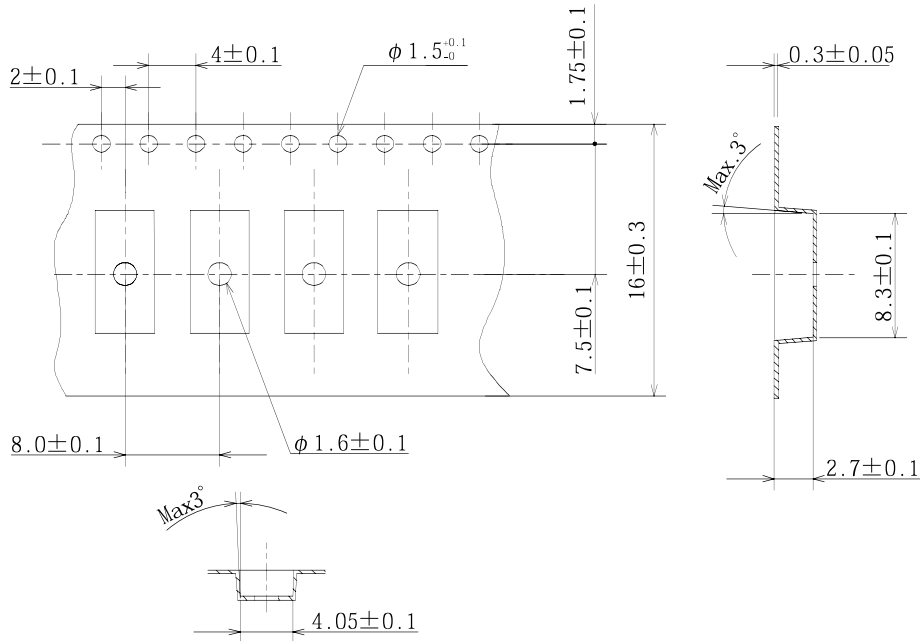

## Reel Dimensions

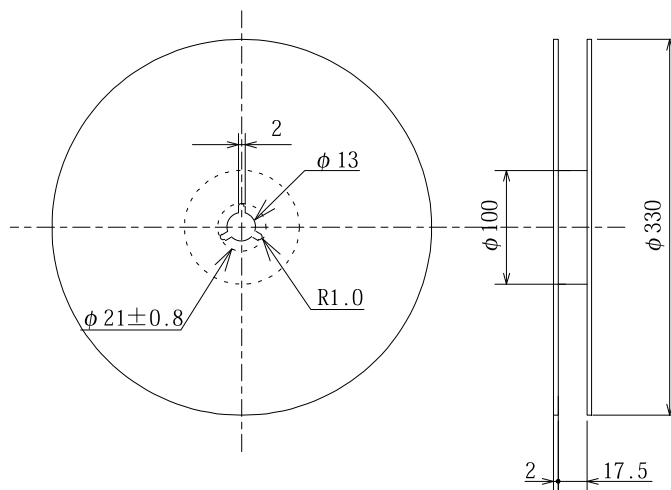

Add: RM#1805, East Wing, TianAn Hi-tech Plaza Phase2, TianAn Cyber Park, t, Shenzhen, China  
Tel: (86) 755 88352809 88352810 Fax: (86) 755 88353718 88352499  
E-mail: [jolly@q-crystal.com](mailto:jolly@q-crystal.com) HTTP://[www.q-crystal.com](http://www.q-crystal.com)

# QUARTZ CRYSTAL



Series6L 308C SURFACE MOUNT PACKAGE FOR TUNING FORK 32.768KHz

## Reflow Soldering Profile

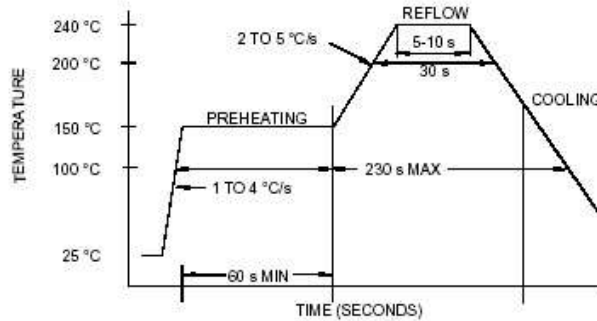

## Iron Soldering Profile.

- △ Iron soldering power :max. 30W .
- △ Pre-heating :150°C / 60sec.
- △ Soldering Tip temperature:350±10°C/3sec.Max.
- △ Solder paste:Sn;
- △ Max.1 times for iron soldering.

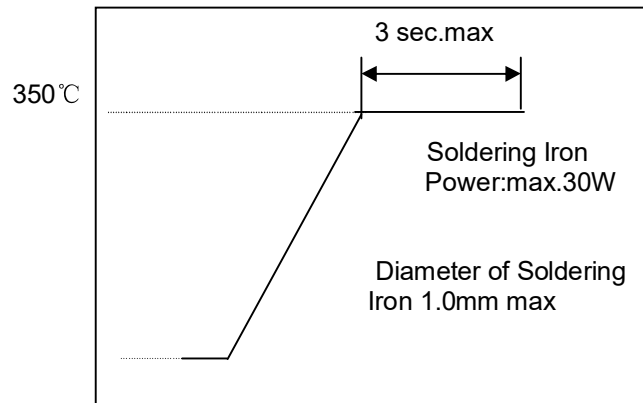

## PART NUMBER

SJK-	6LC	32.768K	12.5	20	40	C
	6LB:206B	Frequency	Load capacitance	Frequency tolerance	E.S.R. 40kohm	temp.range C:-40-85°C
	6LC:308C					

Add: RM#1805, East Wing, TianAn Hi-tech Plaza Phase2, TianAn Cyber Park, t, Shenzhen, China  
 Tel: (86) 755 88352809 88352810 Fax: (86) 755 88353718 88352499  
 E-mail: [jolly@q-crystal.com](mailto:jolly@q-crystal.com) HTTP://[www.q-crystal.com](http://www.q-crystal.com)