

Miniature Fuses

Cartridge Fuse-links (CFL)

SCF632(P) Series, Ceramic Tube



Dimensions (mm)

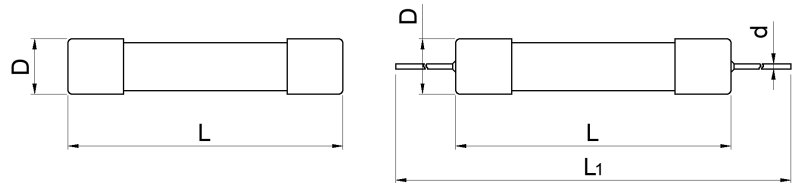

L	L ₁	D	d
31.8 ± 1.0	108 ± 2	Φ6.35 ± 0.20	≤16 A: Φ0.80 ± 0.05 >16 A ~ 30 A: Φ1.00 ± 0.05

Key Features

- Physical Size: Φ6.35 mm × 31.8 mm
- High Breaking Capacity
- Ceramic Tube Construction
- Designed To UL 248-14
- Lead-free (Pb-free)
- RoHS & REACH Compliant

Applications

- Power Supply
- Household Appliance
- Surge Protective Device (SPD)
- Charging Pile
- Smart Home
- Office Equipment
- Electric Tool
- Medical Equipment
- Instruments and Apparatuses

Structure

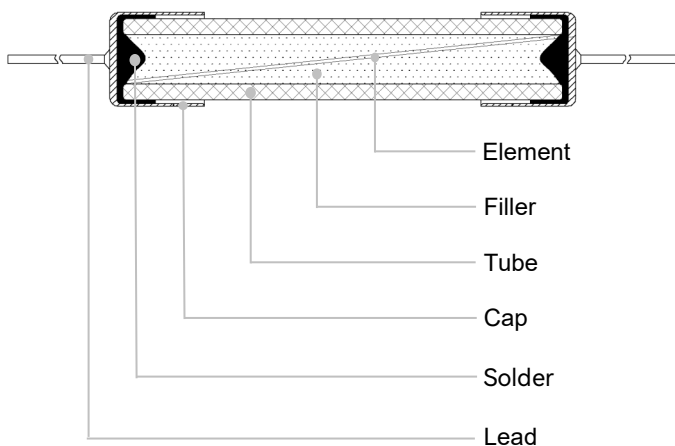

Product Number System

SCF6321.25A250V

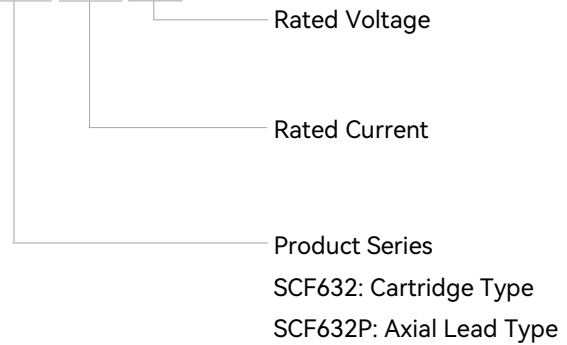

Agency Approvals

Agency Approvals	Agency File Number	Ampere Range
	E345932	1 A ~ 30 A

Glossary

Item	Description
Fuse	A device, by the fusing of one or more of its specially designed and proportioned components, opens the circuit in which it is inserted by breaking the current when this exceeds a given value for a sufficient time. —(IEC 60127)
Rated Current	The rated current of a fuse identifies its current-carrying capacity based on a controllable set of test conditions. Each fuse is marked with its rated current, this rating can be identified with a numeric, alpha, or color code mark. —(IEC 60127)
Rated Voltage	A Max. open circuit voltage in which a fuse can be used, yet safely interrupt an overcurrent. Exceeding the voltage rating of a fuse impairs its ability to clear an overload or short circuit safely. —(IEC 60127)
Ampere Squared Seconds I^2t	The melting, arcing, or clearing integral of a fuse, termed I^2t , is the thermal energy required to melt, arc, or clear a specific current. It can be expressed as melting I^2t , arcing I^2t or the sum of them, clearing I^2t . —(IEC 60127)
Overload	Can be classified as an overcurrent which exceeds the normal full load current of a circuit by 2 to 5 times its magnitude and stays within the normal current path. —(UL 248)
Overcurrent	A condition which exists in an electrical circuit when the normal load current is exceeded. Overcurrent take on two separate characteristics—overloads and short circuits. —(UL 248)
Short Circuit	An overcurrent that leaves the normal current path and greatly exceeds the normal full load current of the circuit by a factor of tens, hundreds, or thousands times. —(UL 248)
Breaking Capacity of a Fuse-link	Value (r.m.s. for AC) of prospective current that a fuse-link is capable of breaking at a stated voltage under prescribed conditions of use and behaviour. —(IEC 60127)

Miniature Fuses

Miniature Fuses

Miniature Fuses

Cartridge Fuse-links (CFL)

SCF632(P) Series, Ceramic Tube

Specifications

Series	Rated Current	Rated Breaking Capacity	Average Typical Melting I^2t^a	Agency Approvals	Environmental	
	(A)			(A ² sec)	 cURus	RoHS
SCF632(P)	1	1500 A @ 250 VAC 10 kA @ 600 / 500 / 400 / 350 / 300 / 250 VAC 50 kA @ 600 / 500 / 400 / 350 / 300 / 250 VDC	1.11	●	●	●
SCF632(P)	1.25		1.87	●	●	●
SCF632(P)	1.6		2.24	●	●	●
SCF632(P)	2		3.85	●	●	●
SCF632(P)	2.5		4.03	●	●	●
SCF632(P)	3.15		9.13	●	●	●
SCF632(P)	4		15.7	●	●	●
SCF632(P)	5		26.7	●	●	●
SCF632(P)	6		42.5	●	●	●
SCF632(P)	6.3		45.5	●	●	●
SCF632(P)	8		78.6	●	●	●
SCF632(P)	10		116	●	●	●
SCF632(P)	12		220	●	●	●
SCF632(P)	12.5		284	●	●	●
SCF632(P)	15		1010	●	●	●
SCF632(P)	16	1320	●	●	●	
SCF632(P)	20	2680	●	●	●	
SCF632(P)	21	6000	●	●	●	
SCF632(P)	25	5430	●	●	●	
SCF632(P)	30	10800	●	●	●	

a: I^2t value is measured at 10 I_n .

Miniature Fuses

Cartridge Fuse-links (CFL)

SCF632(P) Series, Ceramic Tube

Pre-arcing Time/Current Characteristic

1.0 I_N	2.5 I_N
Min.	Max.
60 minutes	30 minutes

Time Current Curve (For Reference Only)

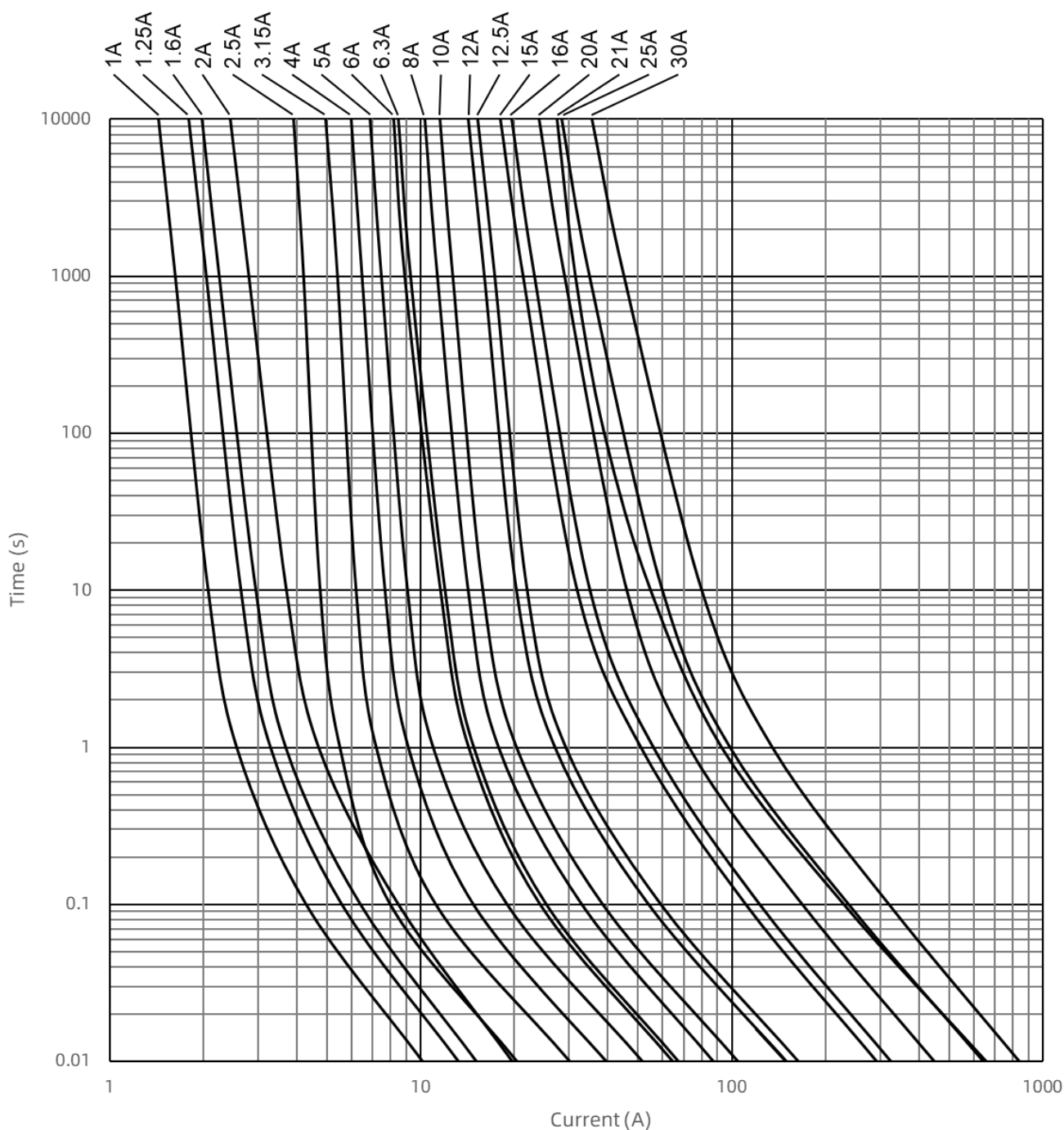

Miniature Fuses

Miniature Fuses

Miniature Fuses

Cartridge Fuse-links (CFL)

SCF632(P) Series, Ceramic Tube

Packaging Information

Dimensions (mm)

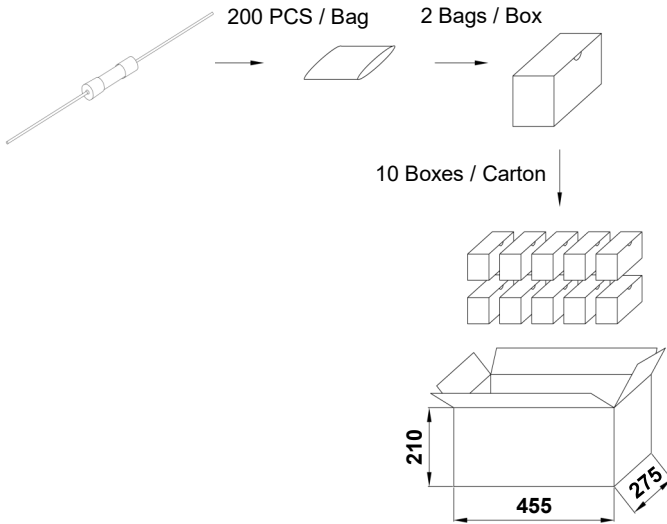
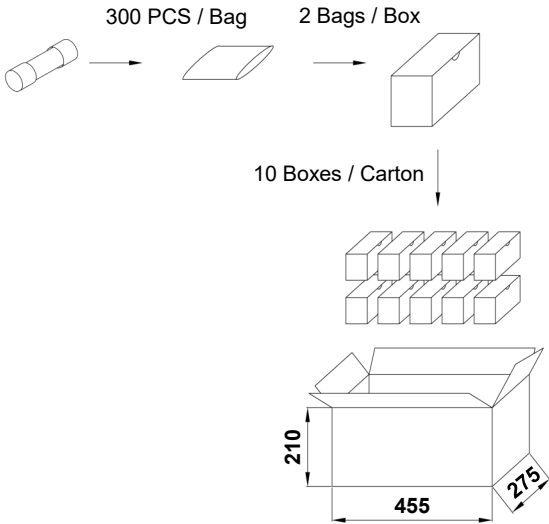

Miniature Fuses

Miniature Fuses

Cartridge Type			
Item	PE Bag	Box	Carton
Q'ty (PCS)	300	600	6,000
Gross Weight (kg)	18.5 ± 10%		

Axial Lead Type			
Item	PE Bag	Box	Carton
Q'ty (PCS)	200	400	4,000
Gross Weight (kg)	13 ± 10%		



ATTENTION

Inspection

Cold Resistance Test

- a. Applied current shall be less than 10% of rated current, at ambient Temp. of (23 ± 2) °C.
- b. 4-Wire Resistance Measurement.

Usage

- a. Do not touch the fuse body or lead wire when power on, avoiding scald or electric shock.
- b. The air pressure is 80 kPa to 106 kPa, corresponding to the altitude of +2000 m to -500 m.

Replacement

For safety reasons, the Fuse is a non-resettable product, please ensure that the alternative Fuse is the same type when replace it.

Storage

Fuse storage should avoid high temperature, high humidity, direct sunlight, and corrosive gases, so as not to affect the solderability of the lead wire. Please use them up within 1 year after receiving the goods.

Miniature Fuses

Cartridge Fuse-links (CFL)

SCF632(P) Series, Ceramic Tube

Installation

Mechanical stress

Do not apply mechanical stress to the fuse body during or after the installation.

Soldering Parameters

Wave soldering Parameters (For Reference Only)

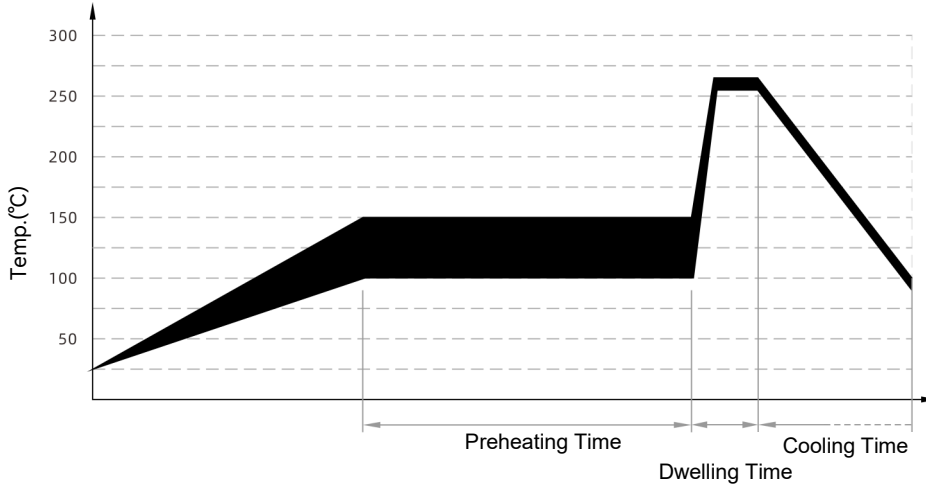

Item	Temp. (°C)	Time (s)
Preheating	100 ~ 150	60 ~ 180
Dwelling	255 ~ 265	4 ~ 8

Recommended Soldering Parameters

Solder Iron Temp.: (350 ± 5) °C

Soldering Time: ≤ 5 s

Lead Wire Bending

If the lead wire has to be bent, please pay attention to the distance between body and the bending point. Refer to the following table.

轴向型 Axial Type	
$L_2 \geq 3 \text{ mm}$	

Installation Position

Do not install the fuse on a location that may often subject to severe continuous vibration.