

**This is a controlled document.**

Hardcopy to be endorsed by authorized person.

Check with Issuing Office or SAP system for latest update.

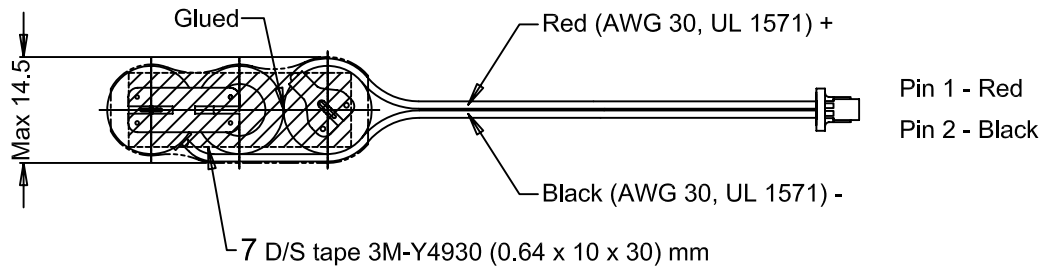

Pin 1 - Red  
Pin 2 - Black

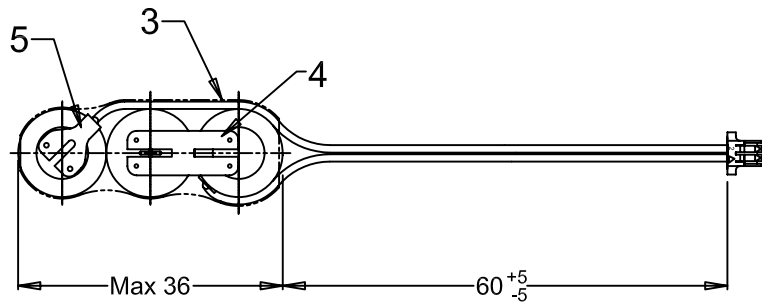

Note : 1) Battery is totally insulated  
2) Battery with non-Standard polarity

Approx.wt : 4 g

No.	Alterations:	Date:	Name:	Dimensions in mm	Material:
0	AO 018/04; Refer to drawing # P01-00014 Rev. 000	2004-02-25	TitisWS	Tolerance: As specified	Refer to part list no: 074534
1	AO C015/04; Change DS tape from 3M#4615 to 3M#4930	2004-03-04	Ida	Projection:	
				Scale: 1 : 1	Description:  <b>3/V15H L WC DT</b> with shrink sleeve & wires with connector
				Loc : 1      Date:      Name:	
				Prepared: 2004-02-25      TitisWS	
				Approved:	

RIGHTS RESERVED TO MAKE TECHNICAL CHANGES, AS A RESULT OF FURTHER DEVELOPMENT, WITHOUT NOTICE. THIS DRAWING IS THE PROPERTY OF VARTA BATTERIES PTE LTD AND MUST NOT BE COPIED OR DISCLOSED TO A THIRD PARTY WITHOUT THE WRITTEN CONSENT OF VARTA BATTERIES PTE LTD.



Dwg. No:	074534	4	0	1
VKB Order No:	55602 403 114			
Released : 2004-02-25				